

Agile & Active Cube

Application Manual VPLC/PLC



TABLE OF CONTENTS

1	General Information about the documentation	6
1.1	Instruction manuals	6
1.2	This document	6
1.3	Warranty and liability	6
1.4	Obligation	7
1.5	Copyright	7
1.6	Storage.....	7
2	General safety instructions and information on use	8
2.1	Terminology	8
2.2	Designated use	8
2.3	Misuse	9
2.4	Residual risks.....	9
2.5	Safety and warning signs on frequency inverter	10
2.6	Warning information and symbols.....	10
2.7	Directives and guidelines to be adhered to by the operator	11
2.8	Operator's general plant documentation.....	11
2.9	Operator's/operating staff's responsibilities.....	12
2.9.1	Selection and qualification of staff	12
2.9.2	General work safety	12
2.9.3	Ear protectors.....	12
2.10	Organizational measures	12
2.10.1	General	12
2.10.2	Use in combination with third-party products.....	12
2.10.3	Transport and storage.....	13
2.10.4	Handling and installation	13
2.10.5	Electrical connections.....	13
2.10.6	Safe operation	13
2.10.7	Maintenance and service/troubleshooting	14
2.10.8	Final decommissioning	15
3	Description of System VPLC	16
3.1	Chronological processing.....	18
3.2	Creating a program with function blocks	18
3.2.1	Starting VPLC	18
3.2.2	Saving a file	18
3.2.3	Function block (instruction)	18
3.2.4	Wire 19	
3.2.5	Digital input block.....	19
3.2.6	Analog input block	19
3.2.7	Digital output block.....	19
3.2.8	Analog output block.....	20
3.2.9	Example.....	20
3.2.10	Syntax check	20
3.2.11	Translation and download (to frequency inverter)	21
3.2.12	Starting the PLC	21

3.2.13	Stopping the PLC	21
3.3	User environment	21
3.3.1	Tool bar and menu commands	21
3.3.2	Other menu commands.....	22
3.3.3	Editor.....	22
3.3.4	Library	23
3.3.5	Properties.....	23
3.3.6	Settings: Inputs, outputs and function block.....	24
3.4	Starting the PLC functions.....	27
3.5	Principle for digital functions (input settings [Boolean])	27
3.6	Principle for analog functions.....	29
3.7	Input buffer and output buffer for digital signals	31
3.8	Input buffer and output buffer for analog signals	31
3.8.1	Fixed analog values	33
4	Overview of instructions	34
4.1	Inputs and outputs	44
4.1.1	Inputs of digital functions.....	44
4.1.2	Inputs and outputs of analog functions	45
4.2	Combination of inputs and outputs of instructions	47
4.2.1	Inputs.....	47
4.2.2	Combining input buffer with inputs	49
4.2.3	Combining instructions with one another	51
4.2.4	Activating device functions via the output buffer.....	51
4.2.5	Controlling a digital output via the output buffer.....	53
4.2.6	Controlling an analog output via the output buffer	54
5	Description of digital functions	55
5.1	Superior/Master	56
5.2	P1 and P2 for chronological behavior and jump target.....	57
5.2.1	Chronological behavior	57
5.2.2	Jump target.....	57
5.2.3	Overview table	57
5.3	Boolean operations	58
5.3.1	[1] AND operation	59
5.3.2	[2] OR operation	59
5.3.3	[3] XOR 1 operation.....	60
5.3.4	[4] XOR 1 3 operation	60
5.4	Flip-Flop types	61
5.4.1	[10] RS-Flip-Flop, Superior	61
5.4.2	[110] RS-Flip-Flop, Master.....	62
5.4.3	[20] Toggle-Flip-Flop, Superior	64
5.4.4	[120] Toggle-Flip-Flop, Master.....	65
5.4.5	[30] D-Flip-Flop, Superior	66
5.4.6	[130] D-Flip-Flop, Master	67
5.5	Delays	68
5.5.1	[40, 41, 42] Delay (retriggerable), Superior.....	71
5.5.2	[140, 141, 142] Delay (retriggerable), Master.....	72
5.5.3	[50, 51, 52] Delay (non-retriggerable), Superior	73
5.5.4	[150, 151, 152] Delay (non-retriggerable), Master	74

5.6	Timer functions	75
5.6.1	[60, 61, 62] Monoflop (retriggerable), Superior	75
5.6.2	[160, 161, 162] Monoflop (retriggerable), Master	76
5.6.3	[70, 71, 72] Monoflop (non-retriggerable), Superior	77
5.6.4	[170, 171, 172] Monoflop (non-retriggerable), Master	78
5.6.5	[80, 81, 82] Clock generator Superior	79
5.6.6	[180, 181, 182] Clock generator, Master	80
5.7	Digital multiplexer	81
5.7.1	[90] Digital Multiplexer (Data Set Number)	81
5.8	Switch	81
5.8.1	[91] Switch Data Set	81
5.9	Error functions	81
5.9.1	[95] Triggering of an error	81
5.9.2	[96] Acknowledging an error	83
5.10	Debouncer	84
5.10.1	[97] Debouncer	84
5.11	No operation	84
5.11.1	[99] NOP (no operation)	84
5.12	Jump functions	85
5.12.1	[100] Jump function	85
5.12.2	[101] Jump function for loops	86
6	Description of analog functions	87
6.1	Behavior	87
6.2	Comparators	88
6.2.1	[301, 302] Comparator (comparison of two variables)	88
6.2.2	[303, 304] Comparator (comparison of constant to variable)	89
6.2.3	[308] Comparator for motion blocks	91
6.2.4	[309] Position comparator (long)	92
6.2.5	[310] Analog hysteresis	93
6.2.6	[311, 312] Window comparator (comparison of two variables)	94
6.2.7	[313, 314] Window comparator (comparison of constant to variable)	96
6.2.8	[320] Min/Max	97
6.2.9	[321] Min / Max for position values (Long)	98
6.2.10	[322] Min/Max in time window	99
6.2.11	[323] Min/Max for positions (Long) in time window	99
6.3	Mathematical functions	100
6.3.1	Addition and subtraction	101
6.3.2	Multiplication	102
6.3.3	Division	105
6.3.4	[339] Multiplication and division	107
6.3.5	[340] Average function	107
6.3.6	[341] Absolute value of two orthogonal components (2 D vector)	108
6.3.7	[342] Absolute value of three orthogonal components (3 D vector)	108
6.3.8	[350] Integrator	109
6.3.9	[351] Differentiator (D-element)	110
6.3.10	[360] Absolute value function	111
6.3.11	[361] X ² , SQR (I1)	111
6.3.12	[362] X ³ , (Cube (I1)	112
6.3.13	[363] √X, square root of I1	112
6.3.14	[364] Modulo	113

6.4	Controller	114
6.4.1	[370] P controller.....	114
6.4.2	[371] PI controller (Tn in milliseconds).....	114
6.4.3	[372] PI controller (Tn in seconds)	115
6.4.4	[373] PD(T1) controller	115
6.4.5	[374] PID(T1) controller (Tn in milliseconds).....	116
6.4.6	[375] PID(T1) controller (Tn in seconds).....	118
6.5	Filters	120
6.5.1	[380] PT1 element.....	120
6.5.2	[381] Time average	121
6.5.3	[382] Ramp limitation	121
6.5.4	[383] Spike filter (average of three).....	122
6.6	Analog switch	124
6.6.1	[390] Analog multiplexer (data set number)	124
6.6.2	[391] Analog changeover switch	124
6.6.3	[392] MUX for position values (data set number), Multiplexer	125
6.6.4	[393] Changeover switch for position values (Long).....	126
6.7	Parameter access.....	127
6.7.1	Writing parameters	127
6.7.2	Reading parameters.....	131
6.8	Limiters	135
6.8.1	[440] Limiter (Const.)	135
6.8.2	[441] Limiter (variable)	136
6.9	Counters.....	137
6.9.1	[450] Up/Down counter with analog output.....	137
6.9.2	[451] Stopwatch with analog output	138
6.10	Positioning functions	140
6.10.1	[501] Start motion block as single motion	140
6.10.2	[502] Start motion block in automatic mode.....	141
6.10.3	[503] Stop motion block.....	142
6.10.4	[504] Continue motion block	142
6.10.5	[505] Resume motion block.....	143
6.10.6	[506] Start homing	143
6.10.7	[507] Check state	144
6.11	Bit functions for analog input values.....	145
6.11.1	[200] Bit NOT operation	145
6.11.2	[201] Bit AND/NAND operation	146
6.11.3	[202] Bit OR/NOR operation	147
6.11.4	[203] Bit XOR/XNOR operation	148
6.11.5	[210] Bit shift right	149
6.11.6	[211] Bit arithmetical shift right	149
6.11.7	[212] Bit shift left	150
6.11.8	[213] Bit roll right.....	150
6.11.9	[220] Output one bit.....	151
6.11.10	[221] Unite four bits to form a word	151
6.11.11	[222] Add two bits to a word.....	152
7	Examples of combinations in the function table	154
7.1	Write index and read index	154
7.1.1	Write index and read index for FT-instructions.....	154
7.1.2	Write index and read index for the digital input buffer	155
7.1.3	Write index and read index for the analog input buffer and FT fixed values	156

7.2	Run/Stop	158
7.2.1	Example Run/Stop	158
7.3	Example 1: Combining two digital outputs	159
7.4	Example 2: Combining several FT-instructions	160
7.5	Example 3: Parameterization of logic diagram	163
8	Actual values, output signals and messages	164
8.1	Actual values of digital functions	164
8.2	Actual values of analog functions	165
8.3	Signals for digital outputs of device	166
8.4	Signals for analog outputs of device	167
8.5	Signal sources for device function	167
8.6	Error messages of instruction "95 - Triggering an error"	167
9	Operation as state machine.....	168
9.1	Example of a controller	168
10	List of parameters	176
10.1	Actual values.....	176
10.2	Parameters of function table	177
11	Annex.....	179
11.1	Mask: Diagram for digital instructions of function table.....	179
11.2	Mask: Functions settings	180
Index.....		182

1 General Information about the documentation

1.1 Instruction manuals

For better clarity, the documentation is structured according to the customer-specific requirements made on the frequency inverter.

Quick Start Guide

The "Quick Start Guide" describes the basic steps required for the mechanical and electrical installation of the frequency inverter.

Operating Instructions

The operating instructions document the complete functionality of the frequency inverter. It describes the parameters required for special purposes, adjustment to the application, and the numerous additional functions in detail.

Application Manual

The application manual supplements the documentation for purposeful installation and commissioning of the frequency inverter. It provides information on various topics related to the use of the frequency inverter in the context of specific applications.

Installation instructions

The installation manual describes the installation and use of devices, complementing the "Quick Start Guide" and the user manual.

1.2 This document

The present user manual complements the Operating Instructions and the "Quick Start Guide" for the frequency inverters of the AXIA device series.

It contains important information on the installation and the use of the product in its specified application range. Comply with user documentation to avoid risks, to minimize repair cost and downtimes and to increase the reliability and service life of the frequency inverter.

For this reason, make sure you read the user manual and other relevant documents carefully.

IMPORTANT:

Compliance with the documentation is required to ensure safe operation of the frequency inverter. Bonfiglioli Deutschland GmbH shall not be held liable for any damage caused by any non-compliance with the documentation.



In case you encounter any problems not sufficiently covered by the documentation, please contact the manufacturer.



For safe commissioning and operation of the AXV (AXIA) series, comply with the following documentation:

- This Operating Instructions Document
- Co-applicable Safety manual

1.3 Warranty and liability

BONFIGLIOLI Deutschland GmbH (hereinafter referred to as "manufacturer") states that the contents of this Operating Instructions document do not form part of any previous or existing agreement, assurance or legal relationship between the manufacturer and the user of the Operating Instructions (hereinafter referred to as the "User"). Neither are they intended to supplement or replace such agreements, assurances or legal relationships. Any obligations of the manufacturer shall solely be based on the relevant purchase agreement which also includes

the complete and solely valid warranty stipulations. These contractual warranty provisions are neither extended nor limited by the specifications contained in this documentation.

The manufacturer reserves the right to correct or amend the specifications, product information and omissions in these operating instructions without prior notice. The manufacturer assumes no responsibility to update these Operating Instructions. The manufacturer shall not be liable for any damage, injuries or costs which may be caused by the aforementioned reasons.

In addition, the manufacturer excludes any warranty and disclaims all liability, including without limitation direct, indirect, special, punitive, incidental, exemplary or consequential damages arising out of or in connection with one or more of the following causes:

- inappropriate use of the frequency inverter,
- non-compliance with the instructions, warnings and prohibitions contained in the documentation,
- unauthorized modifications of the frequency inverter,
- insufficient monitoring of parts of the machine/plant which are subject to wear,
- repair work at the machine/plant not carried out properly or in time,
- catastrophes by external impact and Force Majeure.

1.4 Obligation

These Operating Instructions must be read before commissioning and complied with. Anybody entrusted with tasks in connection with the

- transport,
- assembly,
- installation of the frequency inverter and
- operation of the frequency inverter

must have read and understood the Operating Instructions and, in particular, the safety instructions in order to prevent personal and material losses.

1.5 Copyright

In accordance with applicable law any copyright relating to this document shall remain with

BONFIGLIOLI Deutschland GmbH
Europark Fichtenhain B6
47807 Krefeld
Germany

This document is intended for the operator of the frequency inverter. Any disclosure or copying of this document, exploitation and communication of its contents (as hardcopy or electronically) shall be forbidden, unless permitted expressly.

Any non-compliance will constitute an offense against the copyright law, the law against unfair competition and the German Civil Code and may result in claims for damages. All rights relating to patent, utility model or design registration reserved.

1.6 Storage

The documentation forms an integral part of the frequency inverter. It must be stored such that it is accessible to operating staff at all times. If the frequency inverter is sold on to other users, then the documentation must also be handed over.

2 General safety instructions and information on use

This chapter contains general safety instructions for the Operator and the Operating Staff. At the beginning of certain main chapters, some safety instructions are included which apply to all work described in the relevant chapter. Special work-specific safety instructions are provided before each safety-relevant work step.

2.1 Terminology

According to the documentation, different activities must be performed by certain persons with certain qualifications.

The groups of persons with the required qualification are defined as follows:

Operator

This is the entrepreneur/company who/which operates the frequency inverter and uses it as per the specifications or has it operated by qualified and instructed staff.

Operating staff

The term Operating Staff covers persons instructed by the Operator of the frequency inverter and assigned the task of operating the frequency inverter.

Skilled Personnel

The term Skilled Personnel covers staff that are assigned special tasks by the Operator of the frequency inverter, e.g. installation, maintenance and service/repair and troubleshooting. Based on their qualification and/or know-how, Skilled Personnel must be capable of identifying defects and assessing functions.

Qualified electrician

The term Qualified Electrician covers qualified and trained staff who has special technical know-how and experience with electrical installations. In addition, Qualified Electricians must be familiar with the applicable standards and regulations, they must be able to assess the assigned tasks properly and identify and eliminate potential hazards.

Instructed person

The term Instructed Person covers staff who were instructed and trained about/in the assigned tasks and the potential hazards that might result from inappropriate behavior. In addition, instructed persons must have been instructed in the required protection provisions, protective measures, the applicable directives, accident prevention regulations as well as the operating conditions and verified their qualification.

Expert

The term Expert covers qualified and trained staff who has special technical know-how and experience relating to frequency inverter. Experts must be familiar with the applicable government work safety directives, accident prevention regulations, guidelines and generally accepted rules of technology in order to assess the operationally safe condition of the frequency inverter.

2.2 Designated use

The frequency inverter is designed according to the state of the art and recognized safety regulations.

The frequency inverters are electrical drive components intended for installation in industrial plants or machines. Commissioning and start of operation is not allowed until it has been verified that the machine meets the requirements of the EC Machinery Directive 2006/42/EC and DIN EN 60204-1.

The frequency inverters meet the requirements of the low voltage directive 2014/35/EU and DIN EN 61800-5-1. CE-labelling is based on these standards. Responsibility for compliance with the EMC Directive 2014/30/EU lies with the operator. Frequency inverters are only available at specialized dealers and are exclusively intended for commercial use as per EN 61000-3-2.

No capacitive loads may be connected to the frequency inverter.

The technical data, connection specifications and information on ambient conditions are indicated on the rating plate and in the documentation and must be complied with in any case.

2.3 Misuse

Any use other than that described in "Designated use" shall not be permissible and shall be considered as misuse.

For, example, the machine/plant must not be operated

- by uninstructed staff,
- while it is not in perfect condition,
- without protection enclosure (e.g. covers),
- without safety equipment or with safety equipment deactivated,
- when general requirements, such as operating conditions and technical data, are not met.

The manufacturer shall not be held liable for any damage resulting from such misuse. The sole risk shall be borne by the operator.

Explosion protection

The frequency inverter is an IP 20 ingress protection rating device. For this reason, use of the device in explosive atmospheres is not permitted.

2.4 Residual risks

Residual risks are special hazards involved in handling of the frequency inverter which cannot be eliminated despite the safety-compliant design of the device. Residual risks are not obviously identifiable and can be a potential source of injury or a health hazard.

Typical residual hazards include:

- Electrical hazard
- Danger of contact with energized components due to a defect, opened covers or enclosures or improper working on electrical equipment.
- Danger of contact with energized components in frequency inverter if no external disconnection device was installed by the operator.

To minimize electrical hazards install all covers correctly and close all electrical cabinet doors during operation.

When LEDs and/or other indicating elements on the frequency inverter are not active, the inverter still may be energized.

Before carrying out any work with the device, where contact with energized parts might be possible, always check if the device is deenergized, irrespective of the status of any installed indicating elements.



2.5 Safety and warning signs on frequency inverter

- Comply with all safety instructions and danger information provided on the frequency inverter.
- Safety information and warnings on the frequency inverter must not be removed.





2.6 Warning information and symbols

Hazard classes

The following hazard identifications and symbols are used to mark particularly important information:

	DANGER
	Identification of immediate threat holding a high risk of death or serious injury if not avoided.
	WARNING
	Identification of immediate threat holding a medium risk of death or serious injury if not avoided.
	CAUTION
	Identification of immediate threat holding a low risk of minor or moderate physical injury if not avoided.
	NOTICE
	Identification of a threat holding a risk of material damage if not avoided.



Hazard symbols

Symbol	Meaning	Symbol	Meaning
	General hazard		Suspended load
	Electrical voltage		Hot surfaces
	Danger of crushing		

Prohibition signs

Symbol	Meaning
	No switching; it is forbidden to switch the machine/plant, assembly on

Personal safety equipment

Symbol	Meaning
	Wear body protection
	Wear ear protectors

Recycling

Symbol	Meaning
	Recycling, to avoid waste, collect all materials for reuse

Grounding symbol

Symbol	Meaning
	Ground connection

ESD symbol

Symbol	Meaning
	ESD: Electrostatic Sensitive Devices, i.e. components and assemblies sensitive to electrostatic energy

Information signs

Symbol	Meaning
	Tips and information making using the frequency inverter easier.

Font style in documentation

Text type	Use
0x1234	Representation of object numbers in text (hexadecimal)
1234	Representation of object numbers in tables (hexadecimal)
:01	Colon, 2 digits: Representation of sub-index numbers (hexadecimal)
:1	Colon, 1 digit: Representation of data set numbers (1–4)
<i>Object</i>	Representation of object names
01234	Representation of object value/setting

Example: **0x2099:01** *Auto Setup Type: 0x0000002* (Encoder Offset)

2.7 Directives and guidelines to be adhered to by the operator

The operator must adhere to the following directives and regulations:

- Ensure that the applicable workplace-related accident prevention regulations as well as other applicable national regulation are accessible to the staff.
- An authorized person must ensure, before using the frequency inverter, that the device is used in compliance with its designated use and that all safety requirements are met.
- Additionally, comply with the applicable laws, regulations and directives of the country in which the frequency inverter is used.
- For liquid cooled frequency inverters, comply with the cooling water guideline VGB-R 455 P.
- Any guidelines and directives that may be required additionally shall be defined by the operator of the machine/plant considering the operating environment.

2.8 Operator's general plant documentation

- In addition to the Operating Instructions, the operator should issue separate internal user manuals for the frequency inverter. The Operating Instructions of the frequency inverter must be included in the Operating Instructions of the whole plant.

2.9 Operator's/operating staff's responsibilities

2.9.1 Selection and qualification of staff

- Any work on the frequency inverter may only be carried out by skilled personnel. The staff must not be under the influence of any drugs. Note the minimum age required by law. Define the staff's responsibility pertaining to all work on the frequency inverter clearly.
- Work on the electrical components may only be performed by a qualified electrician according to the applicable rules of electrical engineering.
- The operating staff must be trained for the relevant work to be performed.

2.9.2 General work safety

- In addition to the Operating Instructions of the machine/plant, any applicable legal or other regulations relating to accident prevention and environmental protection must be complied with. The staff must be instructed accordingly.
Such regulations and/or requirements may include, for example, handling of hazardous media and materials or provision/use of personal protective equipment.
- In addition to this Operating Instructions, issue any additional directives that may be required to meet specific operating requirements, including supervision and reporting requirements, e.g. directives relating to work organization, workflow and employed staff.
- Unless approved of expressly by the manufacturer, do not modify the frequency inverter in any way, including addition of attachments or retrofits.
- Only use the frequency inverter if the rated connection and setup values specified by the manufacturer are met.
- Provide appropriate tools as may be required for performing all work on the frequency inverter properly.

2.9.3 Ear protectors

- The frequency inverter produces noise. Due to noise development, frequency inverters should only be installed in normally unstaffed areas.
- Noise emission in operation is < 85 dB(A) in the case of sizes 1 through 4.

2.10 Organizational measures

2.10.1 General

- Train your staff in the handling and use of the frequency inverter and the machine/plant as well as the risks involved.
- Use of any individual parts or components of the frequency inverter in other parts of the operator's machine/plant is prohibited.
- Optional components for the frequency inverter must be used in accordance with their designated use and in compliance with the relevant documentation.

2.10.2 Use in combination with third-party products

- Please note that Bonfiglioli Deutschland GmbH will not accept any responsibility for compatibility with third-party products (e.g. motors, cables or filters).
- In order to enable optimum system compatibility Bonfiglioli Deutschland GmbH offers components facilitating commissioning and providing optimum synchronization of the machine/plant parts in operation.
- If you use the frequency inverter in combination with third-party products, you do so at your own risk.

2.10.3 Transport and storage

- The frequency inverters must be transported and stored in an appropriate way. During transport and storage the devices must remain in their original packaging.
- The units may only be stored in dry rooms which are protected against dust and moisture and are exposed to small temperature deviations only. The requirements of DIN EN 60721-3-1 for storage, DIN EN 60721-3-2 for transport and labeling on the packaging must be met.
- The duration of storage without connection to the permissible nominal voltage may not exceed one year.

2.10.4 Handling and installation

- Do not commission any damaged or destroyed components.
- Prevent any mechanical overloading of the frequency inverter. Do not bend any components and never change the isolation distances.
- Do not touch any electronic construction elements and contacts. The frequency inverter is equipped with components which are sensitive to electrostatic energy and can be damaged if handled improperly. Any use of damaged or destroyed components will endanger the machine/plant safety and shall be considered as non-compliance with the applicable standards.
- Only install the frequency inverter in a suitable operating environment. The frequency inverter is exclusively designed for installation in industrial environments.
- If seals are removed from the case, this can result in the warranty becoming null and void.

2.10.5 Electrical connections

- The five safety rules must be complied with.
- Never touch live terminals. In sizes 1 through 4, the DC-link may have dangerous voltage levels for up to 3 minutes after shutdown.
- When performing any work on/with the frequency inverter, always comply with the applicable national and international regulations/laws on work on electrical equipment/plants of the country in which the frequency inverter is used.
- The cables connected to the frequency inverters may not be subjected to high-voltage insulation tests unless appropriate circuitry measures are taken before.

The five safety rules

When working on/in electrical plants, always follow the five safety rules:

- 1 Isolate
- 2 Secure to prevent restarting
- 3 Check isolation
- 4 Earth and short-circuit,
- 5 Cover or shield neighboring live parts.

2.10.6 Safe operation

- During operation of the frequency inverter, always comply with the applicable national and international regulations/laws on work on electrical equipment/plants.
- Before commissioning and the start of the operation, make sure to fix all covers and check the terminals. Check the additional monitoring and protective devices according to the applicable national and international safety directives.
- During operation, all covers must be installed correctly, and all electrical cabinet doors must be closed. During operation, never open the machine/plant.

- No connection work shall be carried out while power supply is on.
- The machine/plant holds high voltage levels during operation, is equipped with rotating parts (fan) and has hot surfaces. Any unauthorized removal of covers, improper use, wrong installation or operation may result in serious injuries or material damage.
- Some components, e.g. the heat sink or braking resistor, may be hot even some time after the machine/plant was shut down. Don't touch any surfaces directly after shutdown. Wear safety gloves where necessary.
- The frequency inverter may hold dangerous voltage levels until the capacitor in the DC link is discharged. After shutdown, wait for at least 3 minutes before starting any electrical or mechanical work on the frequency inverter. Even after this waiting time, make sure that the equipment is deenergized in accordance with the safety rules before starting the work.
- In order to avoid accidents or damage, only skilled personnel and electricians may carry out the work such as installation, commissioning or setup.
- In the case of a defect of terminals and/or cables, immediately disconnect the frequency inverter from mains supply.
- Persons not familiar with the operation of the frequency inverter and children must not have access to the device.
- Do not bypass nor decommission any protective devices.
- The frequency inverter may be connected to power supply every 60 s. This must be considered when operating a mains contactor in jog operation mode. For commissioning or after an emergency switch-off, a non-recurrent, direct restart is permissible.
- After a failure and restoration of the power supply, the motor may start unexpectedly if the Auto-start function is activated.
If staff are endangered, a restart of the motor must be prevented by means of external circuitry.
- Before commissioning and the start of the operation, make sure to fix all covers and check the terminals. Check the additional monitoring and protective devices according to EN 60204 and applicable the safety directives (e.g. Working Machines Act or Accident Prevention Directives).

2.10.7 Maintenance and service/troubleshooting

Visually inspect the frequency inverter when carrying out the required maintenance work and inspections at the machine/plant.

- Perform the maintenance work and inspections prescribed for the machine carefully, including the specifications on parts/equipment replacement.
- Work on the electrical components may only be performed by a qualified electrician according to the applicable rules of electrical engineering. Only use original spare parts.
- Unauthorized opening and improper interventions in the machine/plant can lead to personal injury or material damage. Any repair work may only be carried out by the manufacturer or persons approved/licensed by the manufacturer. Any repair work must be carried out by qualified electricians. Check protective equipment regularly.
- Before performing any maintenance work, the machine/plant must be disconnected from mains supply and secured against restarting. The five safety rules must be complied with.

2.10.8 Final decommissioning

Unless separate return or disposal agreements were made, recycle the disassembled frequency inverter components:

- Scrap metal materials
- Recycle plastic elements
- Sort and dispose of other component materials



Electric scrap, electronic components, lubricants and other utility materials must be treated as special waste and may only be disposed of by specialized companies.



In any case, comply with any applicable national disposal regulations regarding environmentally compatible disposal of the frequency inverter. For more details, contact the competent local authorities.

After the end of product service life, the user/operator must take the device out of operation.



For more information about the decommissioning of the device refer to the applicable operating instructions document.

Disposal requirements under European Union WEEE regulations

The product is marked with the WEEE symbol shown below.

This product cannot be disposed as general household waste. Users responsible for the final disposal must make sure that it is carried out in accordance with the European Directive 2012/19/EU, where required, as well as the relative national transposition rules. Fulfil disposal also in according with any other legislation in force in the country.



3 Description of System VPLC

With the PLC functions (VPLC), external digital signals and internal logic signals of the frequency inverter can be combined with one another. Via analog and mathematical functions, analog signals can be influenced or compared, the results are available for output. PLC functions are also referred to as instructions.

The results of the instructions can be used by other device functions (e.g. comparator) or output via digital outputs. The results can also be used as input values by other instructions.

The instructions can be configured via function blocks in VPLC.

The functions are processed from index to index (I).

VPLC:

- Up to 32 functions are possible.
- Each function block describes an instruction.
- The processing order corresponds to the order of indices 1 to max. 32.

Input settings (digital)

- Via a **digital** input buffer, digital signal sources (e.g. run signal, error signal) and digital inputs (e.g. IN2D) can be assigned to the instruction inputs. The input buffer enables 16 entries.

Input settings (analog)

- Via an **analog** input buffer, analog signal sources (e.g. frequencies) can be assigned to the instruction inputs. Via the input buffers 4 inputs each can be selected for frequencies, percentages, currents and voltages.

Analog output settings

- Via an output buffer, the output values of the instructions can be made generally (globally) available and used by other functions (e.g. start clockwise, data set change-over) or output via the digital outputs of the device. Up to 16 signal sources can be used as **digital** output buffer, 24 signal sources can be used as **analog** output buffer.
- All output values of the instructions have defined values when the frequency inverter is initialized. They are FALSE (digital instructions) or have value 0 (analog instructions) for all instruction outputs and all output buffer values. Inverted instruction outputs will be TRUE after initialization.
- Processing of the instructions can be activated via button "Start PLC" and deactivated via button "Stop PLC".

Consistent data

The input buffer and output buffer guarantee consistent data during the run time.

Each instruction is described by:

- Instruction (digital: AND, OR etc., analog: addition, absolute value function, etc.).
- Inputs: Inputs of the instructions (digital, analog or position).
- Function block settings: These parameters enable, depending on the selected instruction, setting of delay times, factors or jumps between functions, for example.
- Outputs of instructions: The value of an output can be moved to the output buffer and is now generally (globally) available to other device functions.

Each instruction has two outputs O1 and O2 (O2 = O1 inverted) or O1 = Low word and O2 = High word).

The output values of instructions can also be used as input values in other instructions.

Values are interpreted as Percentage value internal

Internal values of the frequency inverter are processed as percentage value. Frequencies, Currents and voltage are converted.

Also Input- and Output buffer convert into percentage values.

- Current: Refers to the inverter nominal current. The inverter nominal current refers to 100.00 %
- Frequency: Refers to *Maximum Frequency 419*. *Maximum Frequency 419* refers to 100.00 %
- Voltage: Refers to 400 V_{eff} (bzw. 400 √2 V_{peak}). The value refers to 100.00 %.

Mathematical functions use percentage values as input and output values.

Internal conversions

Internal values of the frequency inverter are processed as percentage value. Frequencies, Currents and voltage are converted.

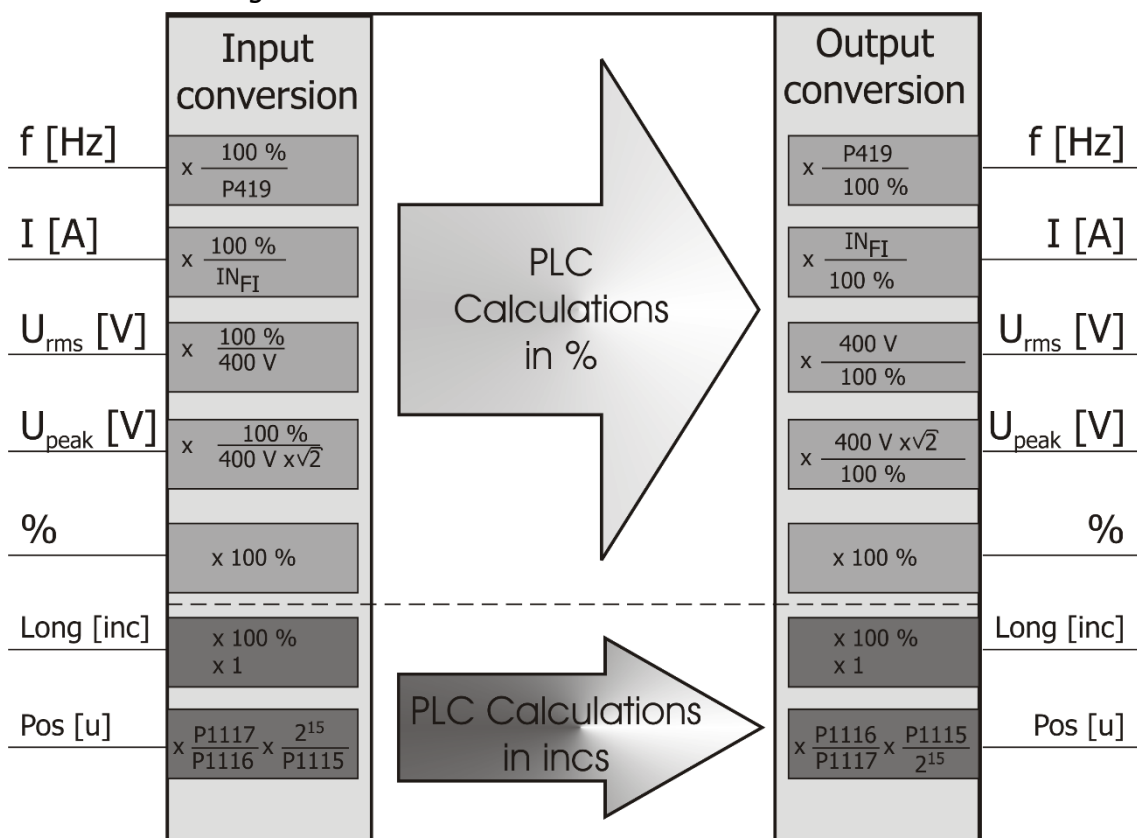

3.1 Chronological processing

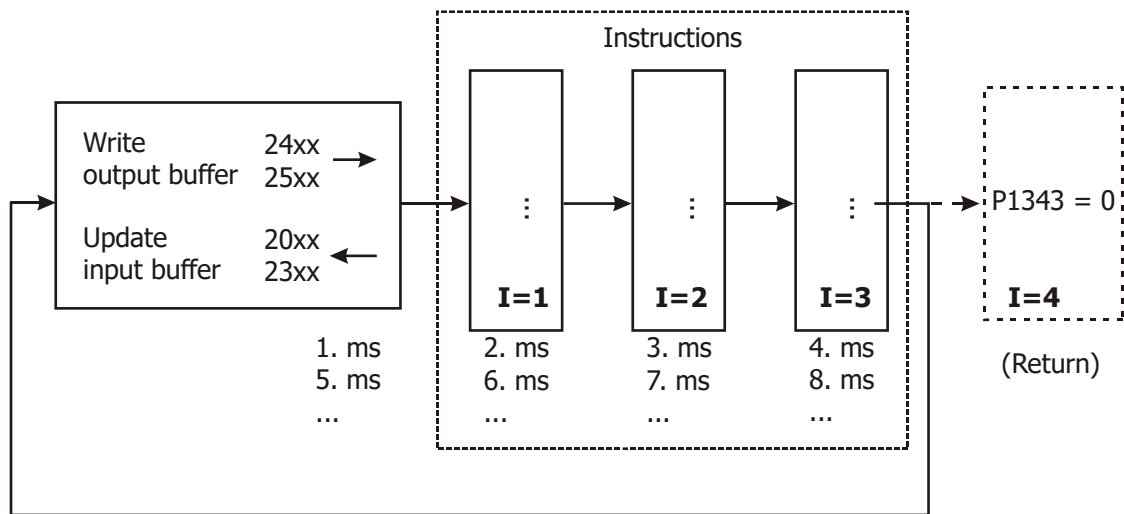

The instructions are processed cyclically. In the first step, the output buffer is written to the global variables, then the input buffer is written to the sources.

Then the instructions are processed, starting with Index 1.

A cycle is complete, if all used and successive instructions have been processed. Then the processing cycle is started again (write output buffer, update input buffer, index 1, index 2 ...).

The processing time of each instruction is approx. 1 ms.

Additionally, 1 ms is required for writing the output signals 24xx/25xx and reading of input signals 20xx/23xx.

As a result, the cycle time is the total of instructions + 1 in milliseconds.

3.2 Creating a program with function blocks

3.2.1 Starting VPLC

In PC software VPlus click on button  to start the editor for VPLC function blocks.

In menu Edit/VPLC settings, select the language for the user environment and the menu commands.

3.2.2 Saving a file

Click button  to save the function block program as a VPLC file.

3.2.3 Function block (instruction)

Drag the required function blocks from the library into the editor window.

- Double-click the function block in order to set up an index for the function block.
- The function blocks are processed in the order of the indices.
- Wrong numbering will be reported by the syntax check .

Depending on the function block, different settings are possible in fields P1 and P2.

3.2.4 Wire

Using the wire tool  to combine the blocks with one another in the editor.

- Use wire to connect the blocks for inputs and outputs to function blocks.
- Use wire to combine the function blocks with one another.

It is not possible to connect the connections of function blocks or inputs and outputs by arranging them on behind the other.

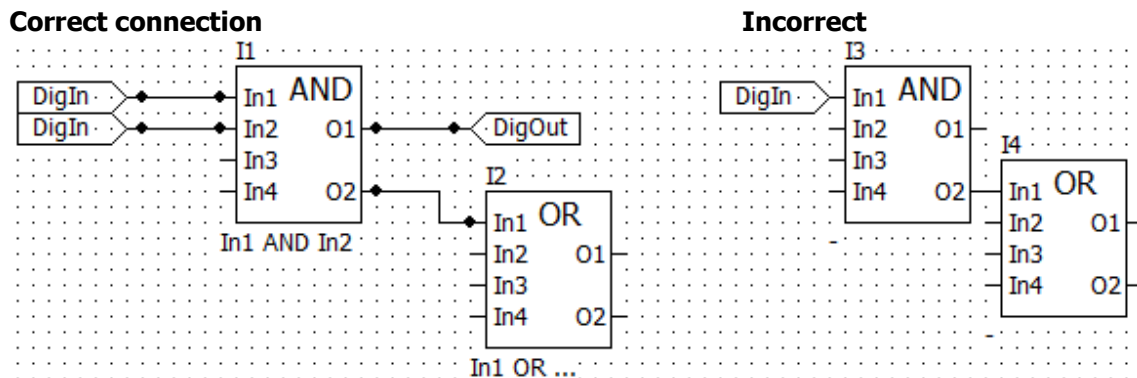

- If the wire is shown in grey after the combination, the combination must be checked.

3.2.5 Digital input block

Combining a digital function block input with a digital input (terminal) or a frequency inverter control signal:

- Drag a block DigIn from the library to the function block input.
- Double-click the block DigIn.
- Select an input buffer for the PLC signal.
- As the global source, select the digital input or control signal to be applied to the functional module input.

3.2.6 Analog input block

Combining an analog function block input to an analog input (terminal) or a frequency inverter signal:

- Drag a block "Analog In" from the library to the function block input.
- Double-click the block "Analog In".
- Select a physical quantity or percentage for the PLC signal.
- Select percent if a signal at the analog input (terminal) of the frequency inverter is to be applied to the function block input.
- As the global source, select the signal to be applied to the functional module input.

3.2.7 Digital output block

Combining a digital function block output with a device function or a digital output (terminal):

- Drag a block DigOut from the library to the function block output.
- Double-click the block DigOut. Select an output buffer.

Example:

Selected output buffer	Signal source for device function	Example of device function
1	2401	<i>Start Anticlockwise</i> 69 = 2401 – PLC-Output buffer 1
4	2404	<i>Error acknowledgment</i> 103 = 2404 – PLC-Output buffer 4
	Signal source for digital output (terminal)	Example of digital output (terminal)
1	80	AgilE: Operation mode <i>OUTID (X13.5)</i> 531 = 80 – PLC-Output buffer 1
4	83	ACU: <i>Operation mode digital output 1</i> 530 = 83 – PLC-Output buffer 4

3.2.8 Analog output block

Combining an analog function block output with a device function or an analog output (terminal):

- Drag a block "Analog Out" from the library to the function block output.
- Double-click the block "Analog Out". Select an output buffer.

Example:

Selected output buffer	Signal source for device function	Example of device function
2	2502	AgilE: <i>Reference frequency source1</i> 475 = 2502 – PLC output frequency 2
	Signal source for analog output (terminal)	Example of analog output (terminal)
1	61	AgilE: <i>Analog: Source MFOIA</i> 553 = 61 – Abs. value PLC outp. percent 1

3.2.9 Example

Digital

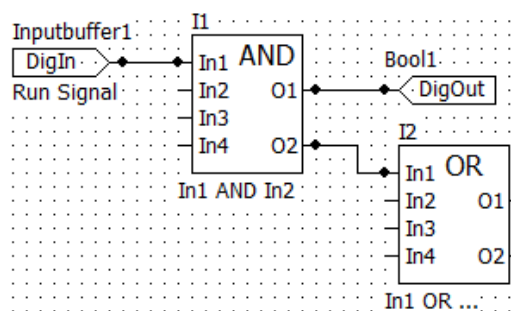

Analog

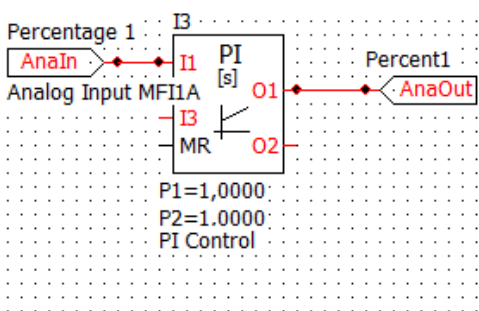

Run Signal as Input Signal

Output O1 via output buffer (Bool1).

Analogue input MFI1A as input value (Percentage 1).

Output O1 via buffer Percentage 1 (Percent1).

3.2.10 Syntax check

Start the syntax check by clicking button . In the syntax check window, click on the error message in bottom area. The cause of the error is marked in the editor window.

3.2.11 Translation and download (to frequency inverter)

Click button  to translate the function block program to parameter settings and download them to the frequency inverter. Only if this function executed will the data in the frequency inverter be changed. The syntax must be free from errors.

Before the translation and download, stop the PLC by clicking button .

3.2.12 Starting the PLC













Run the function block opened in the editor by clicking on button .

3.2.13 Stopping the PLC

Stop the started function block by clicking on button .

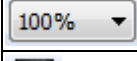
3.3 User environment

3.3.1 Tool bar and menu commands

		Function	Menu command
	New file	Create a new VPLC file.	File → New
	Open VPLC file	Open an existing VPLC file.	File → open
	Save file	Save the program created by means of function block as a VPLC file.	File → Save
	Select	Select function blocks or wire in editor.	–
	Place function block	Place function block selected in the library in the editor.	–
	Wire tool	Connect function block to one another or to inputs/outputs.	–
	Add comment	Insert a text field for comments in the editor.	–
	Undo	Undo the last action. Up to 16 actions can be undone.	Edit → Undo
	Redo	Redo a function undone before.	Edit → Redo
	Zoom	Increase or reduce the view in the editor.	–
	Syntax check	Check the function block program for errors. Click on the error message to mark the cause of the error in the editor.	–
	Translate and download	Translate the function block program to parameter values and download them to the frequency inverter.	PLC → Translate and download to frequency inverter
	Stop PLC	Stop the function block program.	–
	Start PLC	Start the function block program.	–

3.3.2 Other menu commands

Function		Menu command
Save a VPLC file under a new file name.		File → Save as
Export a VPLC file to a VCB file. The VCB file containing the parameter values created by the PLC functions can be edited in VPlus.		File → Export to VCB
Opens the print setup window. Prints the editor area.		File → Print
Adjust the page size of the editor.		File → Page setup
View the page as it will be when printed.		File → Print preview
Select all objects in editor.		Edit → Select all
Opens the VPLC setup window:		Edit → VPLC setup
Interface:	VPlus (auto) is displayed if VPLC was started in VPlus (default setting). COM: The available interfaces are displayed. Only if VPLC is started without VPlus.	
Language:	Select the language of the user environment and the menu commands.	
Apply texts from inverter:	The language selected at the frequency inverter is applied to the signal sources in VPLC.	
Show parameter values:	The values of fields P1 and P2 of the function block settings will be displayed below the function block.	
Sheet size:	Adjust the page size of the editor.	
The changes made with VPLC are deleted in the frequency inverter and reset to the default settings.		PLC → Delete
Apply the function block program to parameter values and download them to the frequency inverter. While edited in the editor, the function block program is not changed in the frequency inverter. Changes will only be applied to the frequency inverter by this command.		PLC → Translate and download to frequency inverter



Working on the sheet does not change the program inside the frequency inverter. Only via the Download Command, the changes of the PLC program are loaded to the frequency inverter.

3.3.3 Editor

In the editor, PLC programs are displayed graphically.

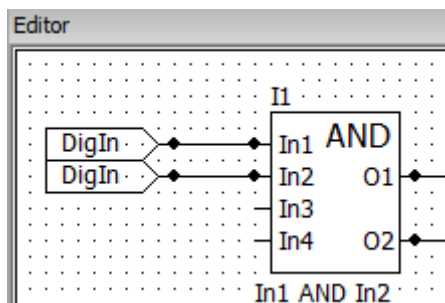

3.3.4 Library

From the library, the blocks for inputs and outputs and function blocks can be dragged to the editor window.

Alternatively, you can click button "Activate function block". In this way, the function block selected in the library can be inserted in the editor window.

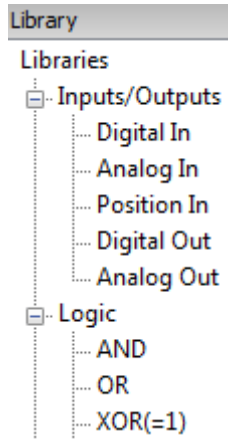

3.3.5 Properties

The properties of the function block selected in the library will be displayed.

- Number of instruction
- Function of inputs (I) and outputs (O) of instruction
- Function of input fields P1 and P2. Via P1 and P2, the function block can be adjusted to the application.

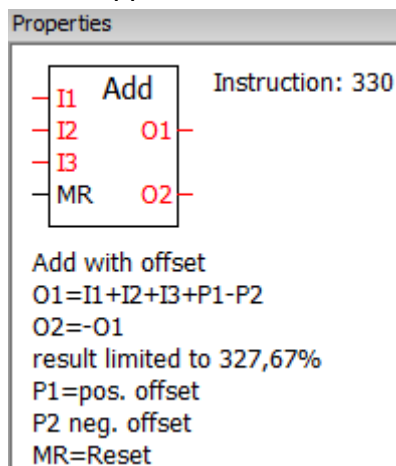

3.3.6 Settings: Inputs, outputs and function block

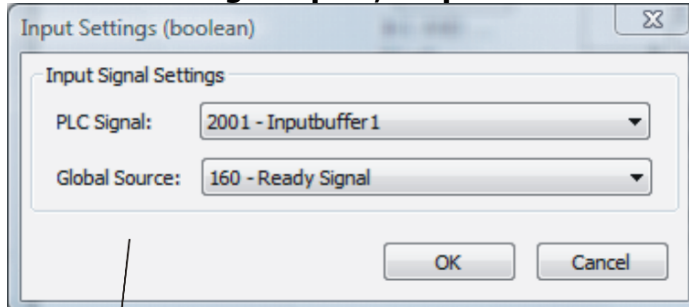

A digital signal of the frequency inverter shall be a command:
Select an input biffer for PLC-Signal.
Select a global source for the input buffer.

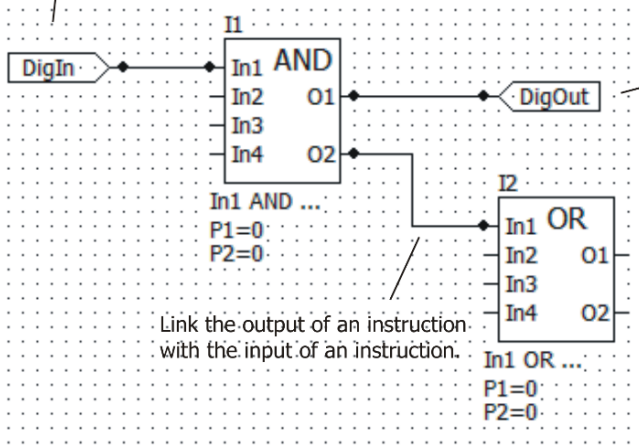

Link the output of an instruction with the input of an instruction.

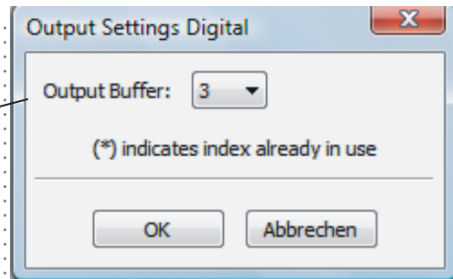

Control functions of the frequency inverter with an output signal.
Example:
Output buffer: 3
Parameter *Start Clockwise* **68**
= 2403 - PLC Output buffer 3

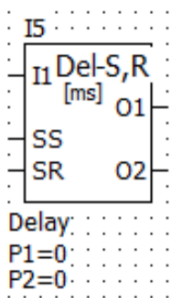

Double click

Additional settings:
Adapt the function to the application. In example Delay time of an Edge Delay.

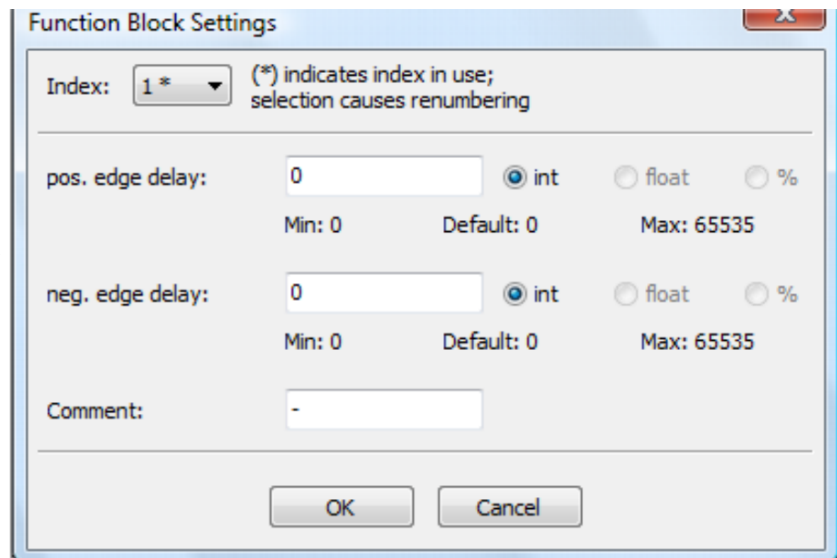

In the editor, double-click a block. The dialog window will be opened.

Block	Dialog window
	<div style="border: 1px solid gray; padding: 5px;"> <p>Eingangssignal Einstellungen</p> <p>SPS Signal: 2001 - Inputbuffer 1</p> <p>Globale Quelle: 160 - Ready Signal</p> </div> <p>Assign a digital signal at the control terminals of the frequency inverter or a control signal to an input of a digital function block.</p> <ul style="list-style-type: none"> Select an input buffer for the PLC signal. Select a digital signal as the global source.

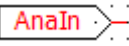
Block	Dialog window
	SPS Signal: <input type="text" value="2301 - Frequency 1"/>
	Globale Quelle: <input type="text" value="10 - Stator Frequency"/>
Assign an analog signal at the control terminals of the frequency inverter or an analog quantity (frequency, current, voltage or percentage) to an input of an analog function block. <ul style="list-style-type: none"> • Select an analog quantity for the PLC signal. • Select an analog signal of the frequency inverter as the global source. 	
SPS Signal: <input type="text" value="2621 - Fixed val. Perc. 1"/>	
Globale Quelle: <input type="text"/>	
Fixed val. Perc. 1 <input type="text" value="2,50"/> %	
<ul style="list-style-type: none"> • Enter a fixed analog value. 	

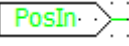
Block	Dialog window
	Eingangssignal Einstellungen SPS Signal: <input type="text" value="2341 - Actual Position"/>
	Festwert: <input type="text"/>
Assign the actual position value to an input of a function block. <ul style="list-style-type: none"> • Select the position value for the PLC signal. 	
Eingangssignal Einstellungen SPS Signal: <input type="text" value="2661 - Fixed val. Position 1"/>	
Fixed val. Position 1 <input type="text" value="20"/>	
Assign a fixed position value to an input of a function block. <ul style="list-style-type: none"> • Select a signal source for the fixed value for the PLC signal. • Enter a fixed position value. 	

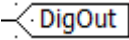
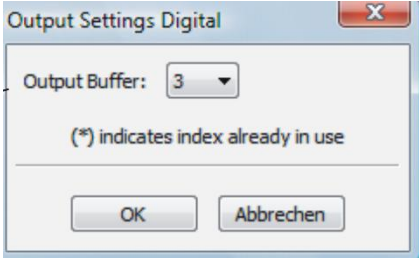
Block	Dialog window
	 <p>Write the output signal of a digital function block to the output buffer. With the output signal of the function block, this enables controlling device functions of the frequency inverter. Output buffers 1 to 16 correspond to signal sources PLC output buffer 2401 to 2416. Select the corresponding signal source for a device function.</p>

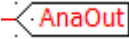
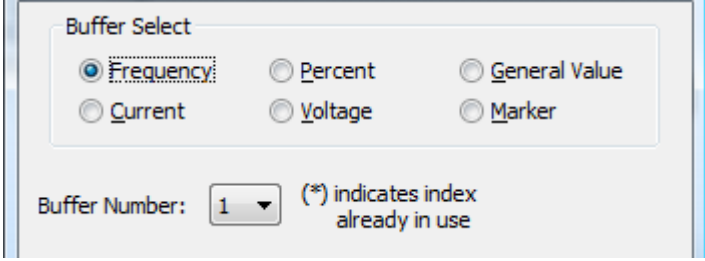
Block	Dialog window
	 <p>Write the output signal of an analog function block to the output buffer. Output buffers 1 to 4 correspond to signal sources 25xx. The signal sources can be used for analog inputs of other function blocks or combined with device functions. Percent Buffer Number 1 and 2 can be output via analog control terminals of the frequency inverter. Select Signal Source 61 – Amount PLC output 1 (Percent Buffer Number 1) or 62 - Amount PLC output 2 (Percent Buffer Number 2) for the parameter of the analog output. Signal sources 161 and 162 have a sign.</p>

Block	Dialog window						
	<p>Index: <input type="text" value="2*"/> (*) indicates index in use; selection causes renumbering</p> <hr/> <p>on time: <input type="text" value="1"/> <input checked="" type="radio"/> int <input type="radio"/> float <input type="radio"/> % Min: 0 Default: 1 Max: 65535</p> <p>ignore edge time: <input type="text" value="0"/> <input checked="" type="radio"/> int <input type="radio"/> float <input type="radio"/> % Min: 0 Default: 0 Max: 65535</p> <p>Comment: <input type="text" value="-"/></p> <p>The index (I) determines the order in which the instructions are processed. Adjust the function block to the application via input fields P1 and P2. The functions of P1 and P2 depend on the function block.</p> <p>In some instructions (i.e. mathematical operations) P1 and P2 can be display as Float, % or Int(ernal).</p> <p>Changing the display does not change the value. For mathematical operations % or Float is recommended.</p> <p>For Times (i.e. Monoflop) the internal Notation Int is recommended.</p> <p>Correlation:</p> <table border="1"> <thead> <tr> <th>%</th> <th>Float</th> <th>Int</th> </tr> </thead> <tbody> <tr> <td>123.45 %</td> <td>1.2345</td> <td>12345</td> </tr> </tbody> </table>	%	Float	Int	123.45 %	1.2345	12345
%	Float	Int					
123.45 %	1.2345	12345					

3.4 Starting the PLC functions

By default (factory setting), the PLC functions are stopped and must be started by clicking button "Start PLC". In stop mode, no instructions are processed and the output buffer is not written.

Run the following menu commands:

- Syntax check
- Translation and download (to frequency inverter)
- Start PLC



Instructions can only be edited in stop mode.

3.5 Principle for digital functions (input settings [Boolean])

The digital function processing principle is shown in the following diagram. The digital input buffer comprises 16 PLC signals which can be assigned to global sources. The values in the input buffer are available to the instructions as sources.

The instructions can be combined with up to 4 input values. The outputs of the instructions can be used as inputs of other instructions (non-negated outputs O1 and negated outputs O2). The instructions are processed one after the other, starting with instruction 1. When the processing cycle jumps back to start, the output buffer is written and the input buffer is updated.

Jump functions enable branching off to certain instructions (indices). The instruction parameters of the jump function additionally enable selective writing of the output buffer and updating of the input buffer.

Digital signal sources for the inputs of digital instructions

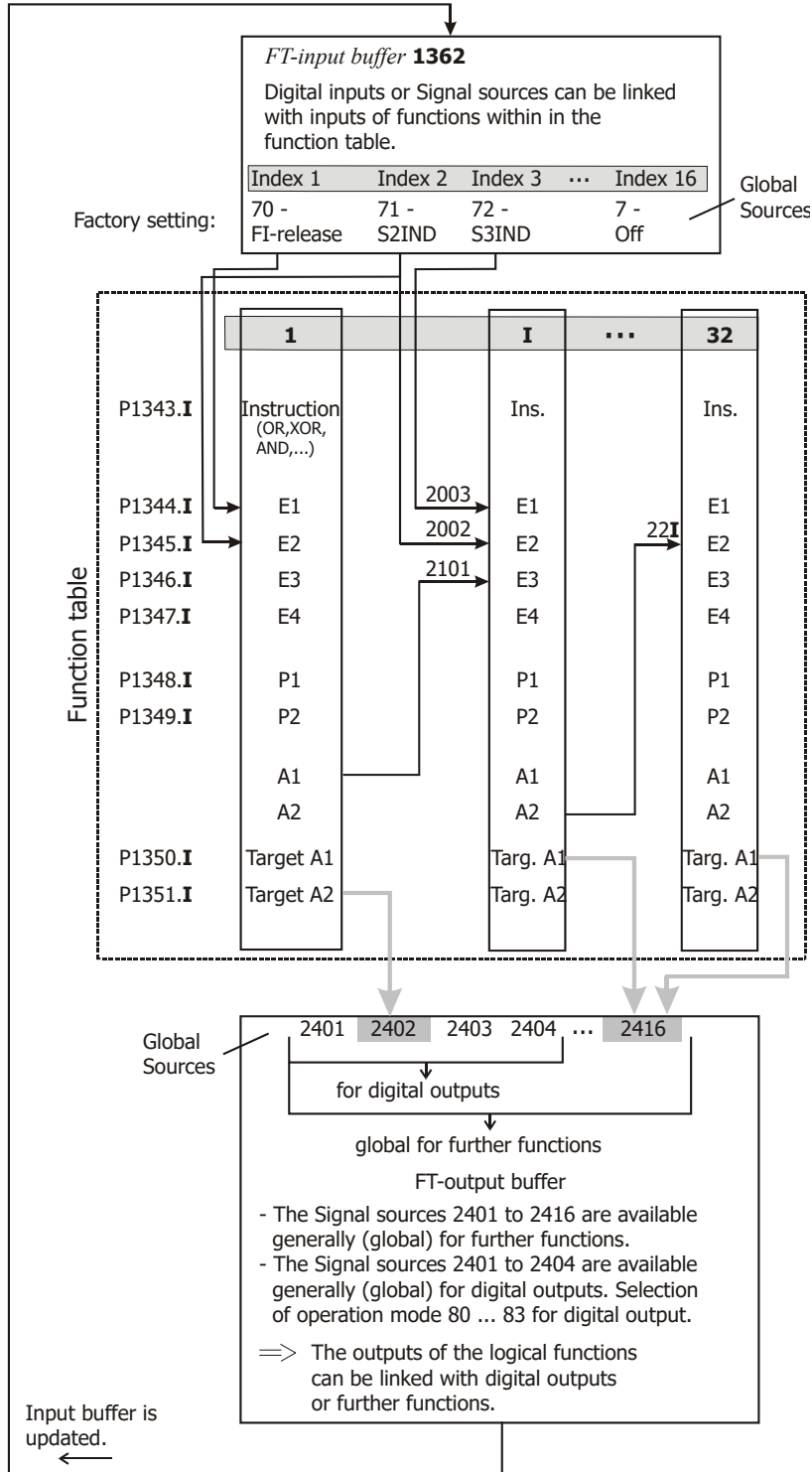

Abbreviations used:

- I: Index of instruction (1 ... 32)
- In: Input of an instruction
- O1, O2: Outputs for combinations with other instructions or outputs for global combinations

First, the output buffer is updated. Then, the input buffer is updated. The values of the global sources are applied to the output buffer. Then, the global input values in the input buffer are updated.

3.6 Principle for analog functions

The analog function processing principle is shown in the following diagram. The analog input buffer comprises fixed values or PLC signals which can be assigned to global signal sources. The values in the input buffer are available to the inputs of the instructions as sources.

Depending on the type of instructions, two function block settings (P1 and P2) are used for adjusting special instruction functions. The outputs of the instructions can be used as inputs by other functions).

In addition, the outputs can be used as a source for global variables.

The instructions are processed one after the other, starting with instruction 1. When the processing cycle jumps back to start, the output buffer is written and the input buffer is updated.

Jump functions enable branching off into certain instructions (indices). The settings of the jump function additionally enable selective writing of the output buffer and updating of the input buffer.

Analog functions can process the following values:

- Frequency
- Current
- Percent
- Voltage
- Position
- Positioning ramp gradient

Analog signal sources and fixed values for the inputs of analog instructions and the output signals of the instructions

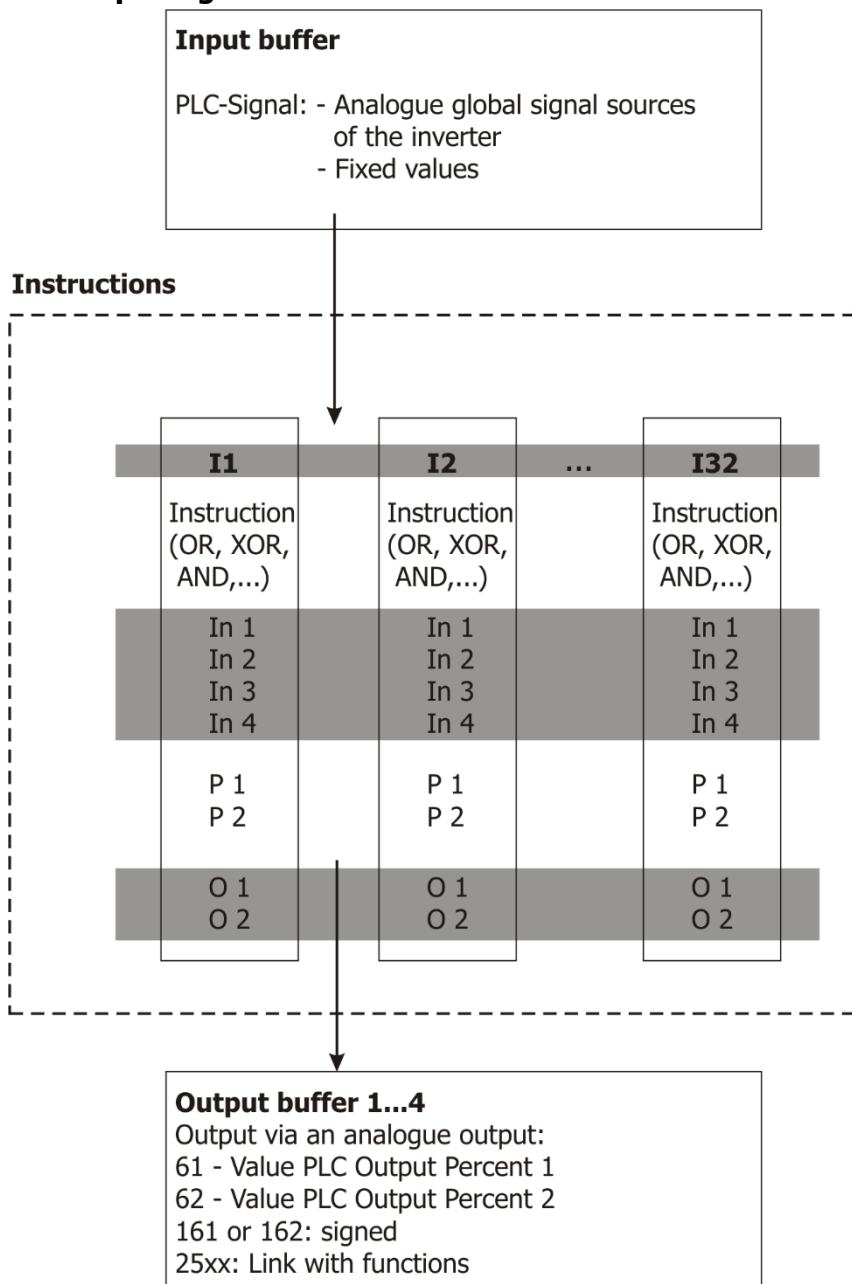

Abbreviations used:

- I: Index of instruction (1 ... 32)
- In: Input of an instruction
- O1, O2: Outputs for combinations with other instructions or for global combinations (e.g. output via an analogue output of the frequency inverter)

3.7 Input buffer and output buffer for digital signals

Input buffer:

The input buffer is updated and the output buffer is written at a defined point of time. In this way it is ensured that the processing within a cycle is performed based on the same input data and inconsistent statuses are avoided.

Output buffer:

For digital outputs (control terminals) of the device, signal sources 2401 to 2404 are available (corresponds to operation modes 80 ... 83 for digital outputs). Operation modes 2401 to 2416 are available to other functions, e.g. comparators.

At the start of a cycle, the input buffer is read and kept in the memory until the next return jump. Then, the instructions are processed. The output buffer is written at the end of the cycle and is available in the global sources after that.

By selective use of the jump function, the input buffer and output buffer can be updated either separately or jointly. This enables setting the digital output signals at certain times (selected by the user) during the processing.



The input and output buffers are set and written during the **return jump**. This is done in one processing cycle. The output buffer is written **first, after that** the input buffer is set.

3.8 Input buffer and output buffer for analog signals

The input buffer is updated and the output buffer is written at a defined point of time. In this way it is ensured that the processing within a cycle is performed based on the same input data and inconsistent statuses are avoided.

- Consistent values; values of identical points of time are processed
- Clear arrangement thanks to limited number of signals
- Conversion to percent values; functions process percent values
- Four indices

In order to write an analog output, you will have to select an output buffer first. Then, the signal must be assigned to the device function.

For analog outputs of the device, the following operation modes are available:

- 61 – "Abs. value PLC outp. percent 1"
- 62 – "Abs. value PLC outp. percent 2"
- 161 – "PLC outp. percent 1"
- 162 – "PLC outp. percent 2"

Based on these values, the input buffer is read at the start of a cycle and kept in the memory until the end of the cycle. Then, the instructions are processed. The output buffer is written at the end of the cycle and is available in the global sources after that. When the input buffer is updated, the output buffer is updated and the cycle restarts.

By selective use of the jump function, the input buffer and output buffer can be updated either separately or jointly. This enables setting the output signals at certain times (selected by the user) during the processing.

The output values of instructions can be saved in the following signal sources of the output buffer. The signal sources 25xx can be used as input values by other instructions.

Signal sources of output buffer	
2501 ... 2504	Output frequency buffer number 1...4
2511 ... 2514	Output current buffer number 1...4
2521 ... 2524	Output percent buffer number 1...4
2531 ... 2534	Output voltage buffer number 1...4
2551 ... 2554	Output general value buffer number 1...4
2561 ... 2564	Output flag buffer number 1...4

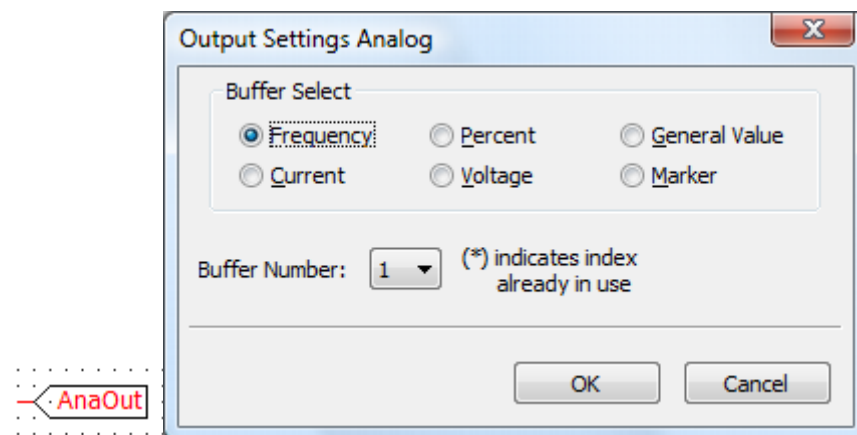
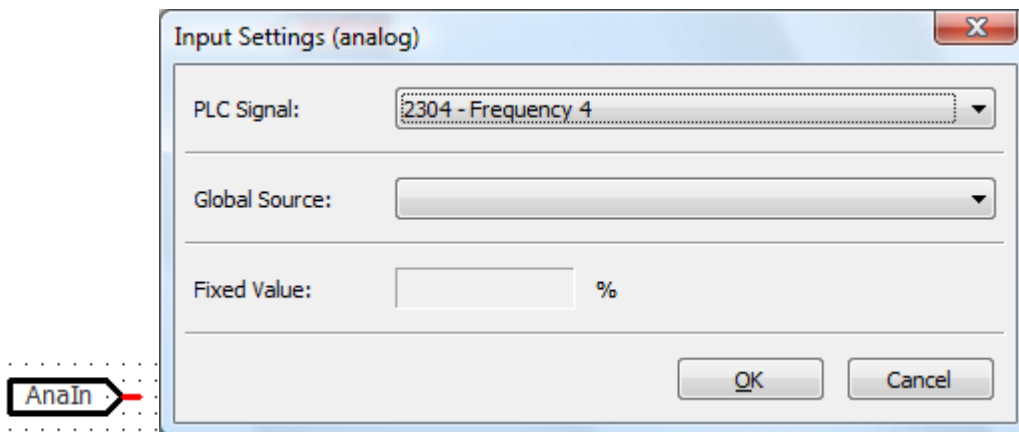

3.8.1 Fixed analog values

For the fixed values of the input buffer, values for physical quantities can be entered.

No.	Fixed value
2601...2604	Fixed frequency values
2611...2614	Fixed current values
2621...2624	Fixed percent values
2631...2644	Fixed voltage values
2651...2654	Fixed general values

Input Settings (analog)

PLC Signal: 2601 - Fixed val. Freq. 1

Global Source:

Fixed val. Freq. 1: 0.00 %

OK Cancel

For PLC signal Fixed General Value of the input buffer, values without physical unit can be entered. The setting range is -327.68% ... +327.68%.

4 Overview of instructions

- C is a configurable constant value.
- V is a variable input value.
- P1 and P2 are input fields in the function block setup for adapting the function to the application

Digital functions

0 -	Off (last item)	Return jump to Instruction 1 (in Index 1). Last function processed in function table. See chapter 0.
-----	-----------------	--

Boolean operations

Digital functions

1 -	AND	Up to 4 inputs are AND combined with one another. Output is TRUE if all inputs are TRUE. See chapter 5.3.1.
2 -	OR	Up to 4 inputs are OR combined with one another. Output is logic TRUE if at least one input is TRUE. See chapter 5.3.2.
3 -	XOR (=1)	Up to 4 inputs are EXCLUSIVE OR-combined with one another. Output is TRUE only if exactly one input is TRUE. See chapter 5.3.3.
4 -	XOR (=1) (=3)	Up to 4 inputs are EXCLUSIVE OR-combined with one another. The output is TRUE if TRUE is present on an odd number of inputs. The output is FALSE if TRUE is present on a straight number of inputs. See chapter 5.3.4.

Flip-Flop types

Digital functions

10 -	RS-Flip-Flop Superior	Input 1: Set; TRUE sets output to TRUE. Input 2: Reset; TRUE sets output to FALSE. Input 3: Superior Set; TRUE sets output to TRUE. Input 4: Superior Reset; TRUE sets output to FALSE. FALSE at Set and Reset: Last output signal state is maintained. See chapter 5.4.1.
20 -	Toggle Flip-Flop Superior	Output signal changes with the positive pulse edge at input 1 or with the negative pulse edge at input 2. TRUE at Superior-Set input (input 3) sets output TRUE. TRUE at Superior Reset input (input 4) sets output FALSE. See chapter 0.
30 -	D Flip-Flop Superior	If a positive edge is received at input 1 (clock pulse input C, Clock) the signal present at input 2 (data input D) is transferred to the output. TRUE at Superior-Set input (input 3) sets output TRUE. TRUE at Superior Reset input (input 4) sets output FALSE. See chapter 5.4.5.

Delays

Digital functions

40 -	Delay Superior ms (retriggerable)	The positive edge at input 1 is delayed by the time set in P1 and the negative edge is delayed by the time set in P2 before switching them through to the output. The delay time starts again with each edge. Times are indicated in milliseconds [ms]. TRUE at Superior-Set input (input 3) sets output TRUE. TRUE at Superior Reset input (input 4) sets output FALSE. See chapter 5.5.1.
------	-----------------------------------	--

41 -	Delay Superior s (retriggerable)	As in operation mode 40, the unit of the times set in P1 and P2 is seconds [s]. See chapter 5.5.1.
42 -	Delay Superior min (retriggerable)	As in operation mode 40, the unit of the times set in P1 and P2 is minutes [min]. See chapter 5.5.1.
50 -	Delay Superior ms (non- retriggerable)	The positive edge at input 1 is delayed by the time set in P1 and the negative edge is delayed by the time set in P2 before switching them through to the output. During the delay time, edges will be ignored. Times are indicated in milliseconds [ms]. TRUE at Superior-Set input (input 3) sets output TRUE. TRUE at Superior Reset input (input 4) sets output FALSE. See chapter 5.5.3.
51 -	Delay Superior s (non- retriggerable)	As in operation mode 50, the unit of the times set in P1 and P2 is seconds [s]. See chapter 5.5.3.
52 -	Delay Superior min (non- retriggerable)	As in operation mode 50, the unit of the times set in P1 and P2 is minutes [min]. See chapter 5.5.3.
Timer functions		Digital functions
60 -	Monoflop Superior ms (retriggerable)	Output signal becomes TRUE with positive clock edge at input 1 or with negative clock edge at input 2. The time set in P1 is the On-Time (High) and the time set in P2 is the ignore edge time (Low). The time is indicated in milliseconds [ms]. The set on-time and the ignore edge time start again with each edge. TRUE at Superior-Set input (input 3) sets output TRUE. TRUE at Superior Reset input (input 4) sets output FALSE. See chapter 5.6.1.
61 -	Monoflop Superior s (retriggerable)	As in operation mode 60, the unit of the times set in P1 and P2 is seconds [s]. See chapter 5.6.1.
62 -	Monoflop Superior min (retriggerable)	As in operation mode 60, the unit of the times set in P1 and P2 is minutes [min]. See chapter 5.6.1.
70 -	Monoflop Superior ms (non- retriggerable)	Output signal becomes TRUE with positive clock edge at input 1 or with negative clock edge at input 2. The time set in P1 is the On-Time (High) and the time set in P2 is the ignore edge time (Low). The time is indicated in milliseconds [ms]. Edges during the selected ON time and the ignore edge time will be ignored. TRUE at Superior-Set input (input 3) sets output TRUE. TRUE at Superior Reset input (input 4) sets output FALSE. See chapter 5.6.3.
71 -	Monoflop Superior s (non- retriggerable)	As in operation mode 70, the unit of the times set in P1 and P2 is seconds [s]. See chapter 5.6.3.

72 -	Monoflop Superior min (non-retriggerable)	As in operation mode 70, the unit of the times set in P1 and P2 is minutes [min]. See chapter 5.6.3.
80 -	Clock generator Superior ms	As long as input 1 is TRUE and input 2 is FALSE, the set pulse pattern is output. The clock pattern is defined by the on-time and the off-time. The time set in P1 is the on-time (High) and the time set in P2 is the off-time (Low). The time is indicated in milliseconds [ms]. TRUE at Superior-Set input (input 3) sets output TRUE. TRUE at Superior Reset input (input 4) sets output FALSE. See chapter 5.6.5.
81 -	Clock generator Superior s	As in operation mode 80, the unit of the times set in P1 and P2 is seconds [s]. See chapter 5.6.5.
82 -	Clock generator Superior min	As in operation mode 80, the unit of the times set in P1 and P2 is minutes [min]. See chapter 5.6.5.
Digital switches		Digital functions
90 -	Digital Multiplexer	Depending on the current data set, the input values are forwarded to the output values Data set = 1: Output 1 = Input 1, Data set = 2: Output 1 = Input 2, Data set = 3: Output 1 = Input 3, Data set = 4: Output 1 = Input 4 See chapter 5.7.1.
91 -	Dataset changeover	Switching-over of data set depending on input signals. See chapter 5.8.1.
Error functions		Digital functions
95 -	Triggering of an error.	A user error is triggered via one of the inputs I1 ... I4. The behavior (error cut-off, shut-down, emergency stop) after triggering can be set up via P2. See chapter 5.9.1.
96 -	Acknowledging an error.	Output 1 indicates if an acknowledgeable error message is present. Via inputs I1 or I2, the error message can be acknowledged. See chapter 5.9.2.
Zero operation		Digital functions
99 -	NOP	Zero operation. The function does not carry out an operation. See chapter 5.11.1.
Jump function		Digital functions
100 -	Jump function	Branching off to index (table column). See chapter 5.12.1.
101 -	Jump function for loops	A function indicated as jump target in P1 is executed as often as indicated in P2. Via the inputs , the loop can be stopped or restarted. See chapter 5.12.2.
110 ... 182		Like instruction types 10 ... 82. Evaluation of Master-Set/Master-Reset instead of Superior-Set/Superior-Reset.

Analog functions:

Debouncer

Analog functions:

97 - Debouncer	The input value will be forwarded to the output only if it has had a constant value for the configured delay (P1: pos. edge, P2: neg. edge). See chapter 5.10.1.
----------------	--

Bit functions for analog input values

Analog functions:

200 - Bit NOT operation	At output 1 O1, the bitwise inverted value of input I1 is output. See chapter 6.11.1.
201 - Bit AND/NAND operation	The input value at I1 is AND combined. Via P2, you can select: P2=1: Combination with input value I2 P2=2: Combination with a mask permanently set up in P1, P2=3: Combination with I2 and P1 See chapter 6.11.3.
202 - Bit OR/NOR operation	The input value at I1 is OR combined. Via P2, you can select: P2=1: Combination with input value I2 P2=2: Combination with a mask permanently set up in P1, P2=3: Combination with I2 and P1 See chapter 6.11.2.
203 - Bit XOR/XNOR operation	The input value at I1 is Exclusive-OR combined. Via P2, you can select: P2=1: Combination with input value I2 P2=2: Combination with a mask permanently set up in P1, P2=3: Combination with I2 and combination of result with P1 See chapter 6.11.4.
210 - Bit shift right	The input value at I1 is shifted to the right bitwise by the number of shifts (P2). Left side is filled with zeroes. See chapter 6.11.5.
211 - Bit arithmetical shift right	The input value at I1 is shifted to the right bitwise by the number of shifts (P2). The most significant bit (sign bit) is maintained. See chapter 6.11.6.
212 - Bit shift left	The input value at I1 is shifted to the left bitwise by the number of shifts (P2). Right side is filled with zeroes. See chapter 6.11.7.
213 - Bit roll right	The input value at I1 is shifted to the right bitwise by the number of shifts (P2). On the left side, the bits leaving on the right side will be inserted. See chapter 6.11.8.
220 - Output one bit	A selected bit of input value 1 is output at output 1. The bit is selected via P1. See chapter 6.11.9.
221 - Unite four bits to form a word	The state of input 1 is copied to the bit of the output specified via P1, the state of input 2 to the next bit, etc. See chapter 6.11.10.
222 - Add two bits to a word	The states at inputs I2 and I3 are inserted in certain bits of the input value 1. The bits are defined by P1 and P2. See chapter 6.11.11.

Comparators		Analog functions
301 -	Comparator (2 inp.)	Input values I1 and I2 are compared. Via P1 and P2, a hysteresis can be adjusted. See chapter 6.2.1.
302 -	Comparator (2 inp.), absolute value	Like operation mode 301, but the absolute values at inputs I1 and I2 are compared. See chapter 6.2.1.
303 -	Comparator (inp. with const.)	Two switching thresholds are adjusted. If the upper threshold P1 is exceeded, the output is switched on. If the lower threshold P2 is decreased, the output is switched off. See chapter 6.2.2.
304 -	Comparator absolute value inp. with const.	Like operation mode 303, but the absolute value at input I1 (variable) is compared to switching thresholds P1 and P2 (constants). See chapter 6.2.2.
308 -	Comparator, active motion block	A motion block range is set up and it is checked if a motion block from this area is active in the case of table positioning. O1 is TRUE if a motion block from range P1 to P2 (motion block from ... to ...) is active. See chapter 6.2.3. Not available for all device series.
309 -	Comparator (Position)	Input values I1 and I2 are compared. Via P1 and P2, a hysteresis can be adjusted. Suitable for position values. See chapter 6.2.4.
310 -	Analog hysteresis	Signal at I3 saves actual value at I1. Via I2 (variable) and P1 (constant), a hysteresis can be set up. If the value of I1 is within the hysteresis, the saved value is output. If the value of I1 is outside of the hysteresis, the current value of I1 is output. See chapter 6.2.5.
311 -	Window comparator (2V)	It is checked if I1 is in the adjusted range (window) around I2. See chapter 6.2.6.
312 -	Window comparator (2V), absolute value	Like operation mode 311, but the absolute values of inputs I1 and I2 are compared. See chapter 6.2.6.
313 -	Window comparator (VC)	A value range (window) is adjusted and it is checked if I1 is within this constant range. See chapter 6.2.7.
314 -	Window comparator (VC), absolute value	Like operation mode 313, but the absolute value of input I1 (variable) is compared to window values P1 (constant) and P2 (constant). See chapter 6.2.7.
320 -	Min / Max	Based on variables I1 and I2 as well as the constants P1 and P2, the minimum or maximum value is determined and output at O1. See chapter 6.2.8.
321 -	Min / Max for position values	Based on variables I1 and I2 (position values) as well as constants P1 and P2, the minimum or maximum value is determined and output. See chapter 6.2.9.

322 - Min / Max in time window	<p>One of the following values is output at O1:</p> <ul style="list-style-type: none"> - the minimum input value at I1 determined over a certain period of time - the maximum input value at I1 determined over a certain period of time - the current input value at I1 <p>See chapter 6.2.10.</p>
323 - Min / Max in time window for positions	<p>One of the following values is output:</p> <ul style="list-style-type: none"> - the minimum position value at I1 determined over a certain period of time - the maximum position value at I1 determined over a certain period of time - the current position value at I1 <p>See chapter 6.2.11.</p>
Mathematical functions	Analog functions
330 - Addition with offset	<p>The input values at I1 and I2 are added up and the input value I3 is subtracted.</p> <p>Via P1 and P2, you can specify a positive offset (is added to the result) and a negative offset (is subtracted from the result), respectively. See chapter 6.3.1.1.</p>
331 - Addition position with offset	<p>The input values at I1 (Long) and I2 (Long) are added up and the input value I3 (Long) is subtracted.</p> <p>In addition, an offset can be specified via P. See chapter 6.3.1.2.</p>
332 - Multiplication	<p>The input values at I1 and I2 as well as parameter value P1 are multiplied. See chapter 6.3.2.1.</p>
333 - Multiplication by long result	<p>The input values at I1 and I2 as well as parameter value P1 are multiplied.</p> <p>The result is divided into low-word and high-word and output at outputs O1 and O2. See chapter 6.3.2.2.</p>
334 - Multiplication by fraction	<p>The input value at I1 is multiplied by the parameter value P1 and divided by parameter value P2. See chapter 6.3.2.3.</p>
335 - Multiplication long with percent	<p>The input value at I1 (long) is multiplied by the parameter value I2 (percentage) and divided by parameter value P2. See chapter 6.3.2.4.</p>
336 - Division	<p>The input value at I1 is divided by the input value at I2 and the input value at I3. See chapter 6.3.3.1.</p>
337 - Division by const.	<p>The input value at I1 is divided by the parameter value P1. See chapter 0.</p>
338 - Reciprocal	<p>The parameter value P1 is divided by the input value at I1. See chapter 6.3.3.3.</p>
339 - Multiplication and division	<p>The input value at I1 is multiplied by the input value at I2 and the result is divided by the input value at I3. See chapter 6.3.4.</p>
340 - Average	<p>The average is calculated from the input values at I1, I2 and I3. See chapter 6.3.5.</p>

341 -	Absolute value 2D vector	The absolute value is formed from the orthogonal (square-angle) input values at I1 and I2. See chapter 6.3.6.
342 -	Absolute value 3D vector	The absolute value is formed from the orthogonal (square-angle) input values at I1, I2 and I3. See chapter 6.3.7.
350 -	Integrator	The input value at I1 is integrated. See chapter 6.3.8.
351 -	Differentiator	The input value at I1 is differentiated. See chapter 6.3.9.
360 -	Absolute value function	The absolute value of the input value at I1 is calculated. See chapter 6.3.10.
361 -	SQR (I1)	The input value at I1 is squared. See chapter 6.3.11.
362 -	Cube (I1)	The input value at I1 is cubed. See chapter 6.3.12.
363 -	Square root	The square root is calculated from the input value at I1. See chapter 6.3.13.
364 -	Modulo	Multiplication and division. O1 = result , O2 = modulo. See chapter 6.3.14.
Controller		Analog functions
370 -	P controller	The control deviation (I1 – I2) is multiplied by the amplification P1. See chapter 6.4.1.
371 -	PI-Controller (ms)	The control deviation (I1 – I2) is multiplied by the amplification P1 an the I component (total of control deviation over time) is added. The integral time is indicated in milliseconds [ms]. See chapter 6.4.2.
372 -	PI-Controller (s)	The control deviation (I1 – I2) is multiplied by the amplification P1 an the I component (total of control deviation over time) is added. The integral time is indicated in seconds [s]. See chapter 6.4.3.
373 -	PD(T1)-Controller (ms)	The control deviation (I1 – I2) is multiplied by the amplification P1. The D component is added. See chapter 6.4.4.
374 -	PID(T1) controller (ms)	The control deviation (I1 – I2) is multiplied by the amplification (=1). The I component and the D component are added. To adjust another amplification, a P-controller must be connected in series. The integral time is indicated in milliseconds [ms]. See chapter 6.4.5.
375 -	PID(T1) controller (s)	The control deviation (I1 – I2) is multiplied by the amplification (=1). The I component and the D component are added. To adjust another amplification, a P-controller must be connected in series. The integral time is indicated in seconds [s]. See chapter 6.4.6
Filters		Analog functions
380 -	PT1 element	The input value at I1 is filtered according to the set filter time constant. See chapter 6.5.1.
381 -	Time average	The average is calculated from the input values at I1 (over a certain period of time). See chapter 6.5.2.
382 -	Ramp limitation	The output value follows the input value at a limited ramp gradient. The ramp gradient can be adjusted. See chapter 0.
383 -	Spike filter	Input spikes are filtered out of the input value at I1. See chapter 6.5.4.

Analog switch		Analog functions
390 -	Analog multiplexer	One of the values I1, I2, P1 or P2 is output. See chapter 6.6.2.
391 -	Analog changeover switch	Depending on the active data set, one of the input values (I1 ... I4) is output. See chapter 6.6.1.
392 -	Analog multiplexer for position values (data set number)	One of the values I1, I2, or P (P1 P2) is output. See chapter 6.6.3
393 -	Analog changeover switch for position values	Depending on the active data set, one of the input values (I1 ... I4) is output. See chapter 6.6.4.
Parameter access (reading and writing parameters)		Analog functions
401 -	Writing frequency parameters	The input value is converted from percent to Hz and written as long parameter. See chapter 6.7.1.1.
402 -	Write current parameter	The input value is converted from percent to A and written as int parameter. See chapter 0.
403 -	Write voltage parameter (eff.)	The effective value at the input is converted from percent to V and written as int parameter. See chapter 6.7.1.3.
404 -	Write voltage parameter (peak)	The peak value at the input is converted from percent to V and written as int parameter. See chapter 0.
405 -	Write percent parameter	The input value is not changed and written as int parameter. See chapter 6.7.1.5.
406 -	Write position parameter	The input value is not changed and written as long parameter. See chapter 0.
407 -	Write long parameter	The input value is put together from of low-word and high-word, not changed and output as long parameter. For use for any long parameter types. See chapter 6.7.1.7.
408 -	Write word parameter	The input value is not changed and written as int parameter. See chapter 6.7.1.8.
421 -	Read frequency parameter	The function reads the value of the parameter set up in P1 "Parameter number" and P2 "Data set/index". The value is converted to a frequency value. See chapter 6.7.2.1
422 -	Read current parameter	The function reads the value of the parameter set up in P1 "Parameter number" and P2 "Data set/index". The value is converted to a current value. See chapter 6.7.2.2
423 -	Read voltage parameter (eff.)	The function reads the value of the parameter set up in P1 "Parameter number" and P2 "Data set/index". The value is converted to a voltage value. See chapter 6.7.2.3

424 -	Read voltage parameter (peak)	The function reads the value of the parameter set up in P1 "Parameter number" and P2 "Data set/index". The value is converted to a voltage value See chapter6.7.2.4
425 -	Read percent parameter	The function reads the value of the parameter set up in P1 "Parameter number" and P2 "Data set/index". The value is converted to a percentage value. See chapter0
426 -	Read position parameter	The function reads the value of the parameter set up in P1 "Parameter number" and P2 "Data set/index". The value is converted to a position value. See chapter6.7.2.6
427 -	Read long parameter	The function reads the value of the parameter set up in P1 "Parameter number" and P2 "Data set/index". The value is converted to a position value. See chapter6.7.2.7
428 -	Read word parameter	The function reads the value of the parameter set up in P1 "Parameter number" and P2 "Data set/index". The value is converted to a percentage value. See chapter 0.
Limiter		<i>Analog functions</i>
440 -	Limitation (const.)	Limitation to fixed values. The input value at I1 is limited to P1 (upper limit) and P2 (lower limit) and output. See chapter 6.8.1.
441 -	Limitation (variable)	Limitation to variable limits. The input value at I1 is limited to I1 (upper limit) and I2 (lower limit) and output. See chapter 0.
Counters		<i>Analog functions</i>
450 -	Up/Down counter	With each positive edge at I1, the output value of the counter is increased by 100.00%/P1. With each positive edge at I2, the output value of the counter is reduced by 100.00%/P1. See chapter 6.9.1.
451 -	Counter with analog output	The stopwatch is running if I1 = "TRUE" and I2 = "FALSE". I3 determines the direction. I4 resets the stopwatch to the start value P1. With P2, a divisor can be set up to scale the output value. See chapter 6.9.2.

Positioning functions

Analog functions

The availability of positioning functions depends on the device series.

501 -	Start motion block as single motion	The motion block selected with P1 is started. Input I1 defines the target position. Input I2 defines the reference speed. See chapter 6.10.1.
502 -	Start motion block in automatic mode	The motion block selected with P1 is started. Input I1 defines the target position. Input I2 defines the reference speed. See chapter 6.10.2.
503 -	Stop motion block	The current motion block is stopped if the release at input I3 is set. See chapter 6.10.3.
504 -	Continue motion block	The stopped motion block is continued if the release at input I3 is set. See chapter 6.10.4.
505 -	Resume Motion Block	A motion block stopped by an error cut-off or mains-off is continued if the release at input I3 is set. See chapter 6.10.5.
506 -	Start homing	The homing operation defined in P1 is started if the release at input I3 is set. See chapter 6.10.6.
507 -	Check state.	While a motion block is running output O1 is set to TRUE. See chapter 6.10.7.

4.1 Inputs and outputs

4.1.1 Inputs of digital functions

The digital functions use digital input signals and digital output signals.

Instruction	Input 1	Input 2	Input 3	Input 4
1 - AND	Input 1	Input 2	Input 3	Input 4
2 - OR	Input 1	Input 2	Input 3	Input 4
3 - XOR (=1)	Input 1	Input 2	Input 3	Input 4
4 - XOR (=1) (=3)	Input 1	Input 2	Input 3	Input 4
10 - RS Flip-Flop Superior	Set	Reset	Superior-Set	Superior-Reset
20 - Toggle Flip-Flop Superior	Input +	Input -	Superior-Set	Superior-Reset
30 - D Flip-Flop Superior	Clock input C	Data input D	Superior-Set	Superior-Reset
4x - Delay Superior (retriggerable)	Input	-	Superior-Set	Superior-Reset
5x - Delay Superior (non-retriggerable)	Input	-	Superior-Set	Superior-Reset
6x - Monoflop Superior (retriggerable)	Input +	Input -	Superior-Set	Superior-Reset
7x - Monoflop Superior (non-retriggerable)	Input +	Input -	Superior-Set	Superior-Reset
8x - Clock generator Superior	Input +	Input -	Superior-Set	Superior-Reset
90 - Digital multiplexer	Input 1	Input 2	Input 3	Input 4
91 - Dataset changeover	Input 1	Input 2	Input 3	Input 4
95 - Triggering of an error.	Trigger	Trigger	Trigger	Trigger
96 - Acknowledging an error.	Acknowledge	Acknowledge	-	-
97 - Debouncer	Input	-	Master-Set	Master-Reset
99 - NOP	-	-	-	-
100 - Jump function	Activate jump function	Jump target	Update input buffer	Update output buffer
101 - Jump function for loops	Finish loop	Restart loop	Update input buffer	Update output buffer
110 - RS Flip-Flop Master	Set	Reset	Master-Set	Master-Reset
120 - Toggle Flip-Flop Master	Input +	Input -	Master-Set	Master-Reset
130 - D Flip-Flop Master	Clock input C	Data input D	Master-Set	Master-Reset
14x - Delay Master (retriggerable)	Input	-	Master-Set	Master-Reset
15x - Delay Master (non-retriggerable)	Input	-	Master-Set	Master-Reset
16x - Monoflop Master (retriggerable)	Input +	Input -	Master-Set	Master-Reset
17x - Monoflop Master (non-retriggerable)	Input +	Input -	Master-Set	Master-Reset
18x - Clock generator Master	Input +	Input -	Master-Set	Master-Reset



In instruction types 40 to 82 and 140 to 182 the "x" is used as a placeholder in the table. The instruction types can be parameterized in three different time bases:

- 0: milliseconds [ms],
- 1: seconds [s],
- 2: minutes [min].

4.1.2 Inputs and outputs of analog functions

The analog functions use at least one analog input signal or output signal. Depending on the instruction, the inputs and outputs have different functions.

Instruction	Input				Output		Parameters	
	1	2	3	4	O1	O2	P1	P1
200 - Bit NOT operation	%	-	b	b	%	%	-	-
201 - Bit AND/NAND operation	%	%	b	b	%	%	%	i
202 - Bit OR/NOR operation	%	%	b	b	%	%	%	i
203 - Bit XOR/XNOR operation	%	%	b	b	%	%	%	i
210 - Bit shift right	%	-	b	b	%	%	-	i
211 - Bit arithmetical shift right	%	-	b	b	%	%	-	i
212 - Bit shift left	%	-	b	b	%	%	-	i
213 - Bit roll right	%	-	b	b	%	%	-	i
220 - output one bit	%	-	b	b	b	b	i	-
221 - Unite four bits to form a word	b	b	b	b	%	%	i	-
222 - Add two bits to a word	%	b	b	b	%	%	i	i
301 - Comp. 2 inp.	%	%	b	b	b	b	xxxx%	xxxx%
302 - Comp. 2 inp., abs. val.	%	%	b	b	b	b	%	%
303 - Comp. inp. with const.	%	-	b	b	b	b	%	%
304 - Comp. inp. with const., abs. val.	%	-	b	b	b	b	%	%
308 - Comp. active motion block	-	-	b	b	b	b	i	i
309 - Comp. (Position)	Pos	Pos	b	b	b	b	Pos	Pos
310 - Analog hysteresis	%	%	b	b	%	%	%	%
311 - W. comp (2V)	%	%	b	b	b	b	%	%
312 - W. comp (2V), abs.val.	%	%	b	b	b	b	%	%
313 - W. comp (VC)	%	-	b	b	b	b	%	%
314 - W. comp (VC), abs.val.	%	-	b	b	b	b	%	%
320 - Min / Max	%	%	b	b	%	%	%	%
321 - Min / Max for position values	Pos	Pos	b	b	Pos	Pos	Pos	Pos
322 - Min / Max in time window	%	-	b	b	%	%	-	-
323 - Min / Max in time window for positions	Pos	-	b	b	Pos	Pos	-	-
330 - Add. with offset	%	%	%	b	%	%	%	%
331 - Add. position with offset	Pos	Pos	Pos	b	Pos	Pos	Pos	Pos
332 - Mult.	%	%	-	b	%	%	%	-
333 - Mult. with long result	%	%	-	b	%	%	%	-
334 - Mult. with fraction	%	-	-	b	%	%	%	%
335 - Mult. long with percent	long	%	%	b	%	%	%	%
336 - Div.	%	-	-	b	%	%	%	%
337 - Div. by const.	%	-	-	b	%	%	%	%
338 - Reciprocal	%	%	%	b	%	%	%	%
339 - Mult. & Div	%	%	%	b	%	%	%	%
340 - Average	%	%	%	b	%	%	i	i
341 - Absolute value 2D vector	%	%	-	b	%	%	%	%
342 - Absolute value 3D vector	%	%	%	b	%	%	%	%
350 - Integrator	%	%	b	b	%	%	i	i
351 - Differentiator	%	-	-	b	%	%	%	-
360 - Absolute value function	%	-	-	b	%	%	-	-
361 - SQR (I1)	%	-	-	b	%	%	-	%
362 - Cube (I1)	%	-	-	b	%	%	-	%
363 - Square root	%	-	-	b	%	%	-	%
364 - Modulo	%	%	%	b	%	%	%	%

Instruction	Input				Output		Parameters	
	1	2	3	4	O1	O2	P1	P1
370 - P controller	%	%	-	b	%	%	i	%
371 - PI-Controller (ms)	%	%	%	b	%	%	i	i
372 - PI-Controller (s)	%	%	%	b	%	%	i	i
373 - PD(T1)-Controller (ms)	%	%	%	b	%	%	i	i
374 - PID(T1) controller (ms)	%	%	%	b	%	%	i	i
375 - PID(T1) controller (s)	%	%	%	b	%	%	i	i
380 - PT1 element	%	%	b	b	%	%	i	-
381 - Time average	%	-	-	b	%	%	-	-
382 - Ramp limitation	%	%	b	b	%	%	%	i
383 - Spike filter	%	%	b	b	%	%	-	-
390 - Analog multiplexer	%	%	b	b	%	%	%	%
391 - Analog changeover switch	%	%	%	%	%	%	-	-
392 - Analog multiplexer for position values (data set number)	Pos	Pos	b	b	Pos	Pos	Pos	Pos
393 - Analog changeover switch for position values	Pos	Pos	Pos	Pos	Pos	Pos	-	-
401 - Writing frequency parameters	%	b	b	b	b	b	i	i
402 - Write current parameter	%	b	b	b	b	b	i	i
403 - Write voltage parameter (eff.)	%	b	b	b	b	b	i	i
404 - Write voltage parameter (peak)	%	b	b	b	b	b	i	i
405 - Write percent parameter	%	b	b	b	b	b	i	i
406 - Write position parameter	Pos	Pos	b	b	b	b	i	i
407 - Write long parameter	%	%	b	b	b	b	i	i
408 - Write word parameter	int	b	b	b	b	b	i	i
421 - Read frequency parameter	-	-	b	-	%	%	i	i
422 - Read current parameter	-	-	b	-	%	%	i	i
423 - Read voltage parameter (eff.)	-	-	b	-	%	%	i	i
424 - Read voltage parameter (peak)	-	-	b	-	%	%	i	i
425 - Read percent parameter	-	-	b	-	%	%	i	i
426 - Read position parameter	-	-	b	-	%	%	i	i
427 - Read long parameter	-	-	b	-	%	%	i	i
428 - Read word parameter	-	-	b	-	%	%	i	i
440 - Limiter (const.)	%	-	-	b	%	%	%	%
441 - Limiter (variable)	%	%	%	b	%	%	-	-
450 - Up/Down counter	b	b	b	b	%	%	i	i
451 - Counter with analog output	b	b	b	b	%	%	i	i
501 - Start motion block as single motion	Pos	%	b	b	Pos	Pos	i	-
502 - Start motion block in automatic mode	Pos	%	b	b	Pos	Pos	i	-
503 - Stop motion block	-	-	b	b	Pos	Pos	-	-
504 - Continue motion block	-	-	b	b	Pos	Pos	-	-
505 - Resume motion block	-	-	b	b	Pos	Pos	-	-
506 - Start homing	-	-	b	b	Pos	Pos	i	-
507 - Check state.	-	-	-	b	b	b	-	-

4.2 Combination of inputs and outputs of instructions

Inputs

Each instruction has 4 inputs. The inputs can be combined with outputs of other instructions or digital inputs or global signal sources.

Outputs

Each instruction has 2 outputs. The two outputs can:

- be combined with inputs of other instructions,
- combined with device functions,
- output via digital or analog outputs of the device.

In the case of digital functions, output 2 has the negated logic state of input 1.



Instructions can only be edited in stop mode. If you try to make any changes while the function table is not in stop mode, an error will be displayed in VPlus and VPLC. The attempted change will not be applied.

4.2.1 Inputs

The inputs can either be combined with the input buffer, fixed values, the outputs of other instructions (normal or inverted) or the global output variables (digital: output buffer or analog: outp. frequency, outp. current, etc.).



The output buffer is updated only with a write operation (e.g. during return jump). The value used originates from the last write operation of the output buffer.

Possible signal sources for the inputs of instructions

6	TRUE
7	FALSE
Combination with digital signal source of input buffer	
2001 ... 2016	Input buffer 1 ... 16
Combination with analog signal source or actual value	
2301 ... 2304	Frequency 1 ... 4
2311 ... 2314	Current 1 ... 4
2321 ... 2324	Percent 1 ... 4
2331 ... 2334	Voltage 1 ... 4
2341	Actual position of table positioning
2351 ... 2354	General source 1 ... 4
Combination with constants	
2380 ... 2392	Auxiliary values (constants) and global flags (status signals)
Combination with digital global signal source of output buffer	
2401 ... 2416	Output buffer 1 ... 16
Combination with analog output of an instruction	
2501 ... 2504	Outp. frequency 1 ... 4
2511 ... 2514	Outp. current 1 ... 4
2521 ... 2524	Outp. percent 1 ... 4
2531 ... 2534	Outp. voltage 1 ... 4

Possible signal sources for the inputs of instructions	
2551 ... 2554	Outp. user 1 ... 4
2561 ... 2564	Flag 1 ... 4
Combination with fixed analog value	
2601 ... 2604	Fixed frequ. 1 ... 4
2611 ... 2614	Fixed current 1 ... 4
2621 ... 2624	Fixed perc. 1 ... 4
2631 ... 2634	Fixed eff. volt. 1 ... 4
2641 ... 2644	Fixed peak volt. 1 ... 4
2651 ... 2654	Fixed gen. 1 ... 4
2661 ... 2664	Fixed position 1 ... 4
2671 ... 2674	Fixed speed pos. 1 ... 4
2681 ... 2684	Fixed ramp pos. 1 ... 4

2380 ... 2392 – Auxiliary values (constants) and global flags (status signals)

2380 - "0.00 (zero percent)":

The auxiliary quantity has constant value 0%.

2381 - "100.00 (one hundred percent)":

The auxiliary quantity has constant value 100%

2382 - "327.67 (maximum value)":

The auxiliary quantity has constant value 327.67%

2383 - "0XFFF (for bitwise combination)":

The auxiliary quantity has constant hexadecimal value 0xFFFF and can be used for bitwise combinations.

2384 - "Fmax (100)":

Auxiliary quantity has constant value 100% of F_{max} (of parameter *Maximum frequency* **419**).

2385 - "Rated motor current in current data set":

The auxiliary quantity is referred to parameter value *Rated current* **371** in the current data set. The constant value is applied to the input of the instruction: 100% corresponds to the value of the rated motor current.

2386 - "Short-time overload current (ILIMIT)":

The auxiliary quantity is referred to the type-dependent overload current. The constant value is applied to the input of the instruction: 100% corresponds to the value of the overcurrent.

2387 - "INIT":

The status signal is TRUE for 64 ms:

after cut-in of supply voltage, or

after start of the PLC functions.

Otherwise, the signal status is "FALSE". The status signal can be combined with Master Set and Master Reset inputs and is used for initializing the functions.

2388 - "RESET":

The status signal is TRUE for 64 ms:
after cut-in of supply voltage, or
after start of the PLC functions or
after disabling of the output stages.

Otherwise, the signal status is "FALSE". The status signal can be combined with Master Set and Master Reset inputs and is used for initializing the functions.

2389 - "IDLE":

The status signal is TRUE if the output stages are disabled.

2390 - "Controller release":

The status signal is TRUE if the output stages are enabled and the magnetizing process has been completed (flux forming finished; drive working).

2391 - "Controller release inverted ":

Inverted status signal of "Controller release".

2392 - "Error_acknowledgeable":

Status signal is TRUE if current error messages can be acknowledged.

4.2.2 Combining input buffer with inputs

4.2.2.1 Digital

If the signal of a digital input (e.g. IN2D) or a signal source (e.g. 162 - Error Signal) is to be applied to the input of an instruction, an input buffer must be set up on this digital input or signal source. As a result, the digital input or signal source is available for the inputs of the instructions.

1st example: Combination of an instruction input with a digital input: The signal at digital input I4ND is to be applied to input 3 of an instruction.

Input signal settings (Boolean)

- PLC signal: e.g. 2003 - Input buffer 3
- Global source: 74-IN4D

4.2.2.2 Analog

Combination of a signal source with the input of an instruction

The signal of an analog input (e. g. MFI1A) or and analog signal source (e. g. "10 - Stator frequency") is to be applied to the input of an instruction:

- In dialog window "Input settings (analog)" select a PLC signal 2301...2334.
- Select a global source.

As a result, the analog input or signal source is available for the inputs of the instructions.

PLC signal
2301 ... 2304 - Frequency 1 ... 4
2311 ... 2314 - Current 1 ... 4
2321 ... 2324 - Percent 1 ... 4
2331 ... 2334 - Voltage 1 ... 4
2351 ... 2354 - General source 1...4

Example: Combination of an instruction input with a signal source: The stator frequency is to be applied to the input of an instruction:

- In dialog window "Input settings (analog)" select a PLC signal 2301-Frequency 1...2304-Frequency 4.
- Select global source "10 Stator frequency".

Combination of a fixed value with the input of an instruction

A fixed analog value (e.g. fixed frequency value) is to be applied to the input of an instruction:

- In dialog window "Input settings (analog)" select a PLC signal 2601...2654.
- Enter a value.

Signal source
2601 ... 2604 - Fixed freq. 1 ... 4
2611 ... 2614 - Fixed current 1 ... 4
2621 ... 2624 - Fixed perc. 1 ... 4
2631 ... 2634 - Fixed eff. volt. 1 ... 4
2641 ... 2644 - Fixed peak. volt. 1 ... 4
2651 ... 2654 - Fixed gen. 1 ... 4
2661 ... 2664 - Fixed position 1 ... 4
2671 ... 2674 - Fixed speed pos. 1 ... 4
2681 ... 2684 - Fixed ramp pos. 1 ... 4

Example: Combination of an instruction input with a fixed value: An adjusted current value is to be applied to an input of an instruction:

- In dialog window "Input settings (analog)" select a PLC signal 2611-Fixed current 1...2164-Fixed current 2.
- Enter a current value [A] value.

4.2.3 Combining instructions with one another

The outputs of the instructions can be combined with inputs by instructions. Use the wire tool.

4.2.4 Activating device functions via the output buffer

If the logic state of an output is to activate a device function, an output buffer must be selected for the digital output of the instruction. For the device function, the corresponding signal source "2401 - PLC Output buffer 1" ... "2416 - PLC output buffer 16" must be selected. If, for example, output buffer 3 was selected for the digital output of the instruction, signal source "2403 - Output buffer 3" must be selected for a device function.

As a result, the output is generally (globally) available to other device functions. The selected signal source must also be assigned to the device function to be activated. Up to 16 signal sources can be used for further processing of logic states of the instruction outputs. A signal source can be assigned to several outputs of instructions.

Example 1: Combination of an instruction output with a device function:

The function "Start anticlockwise" is to be activated via the output of an instruction.

- Dialog window "Settings for digital outputs": Output buffer 1 (other selection also possible). As a result, the output is generally (globally) available to other device functions.
- *Start Anticlockwise* **69** = "2401 - PLC-Output Buffer 1" (according to above selection).

Example 2: Combination of an instruction output with a device function:

The output of an instruction is needed for combination with a device function. This function is no PLC function. The output of the instruction is to be defined as a general (global) signal source and activate the device function "Switch data set 1".

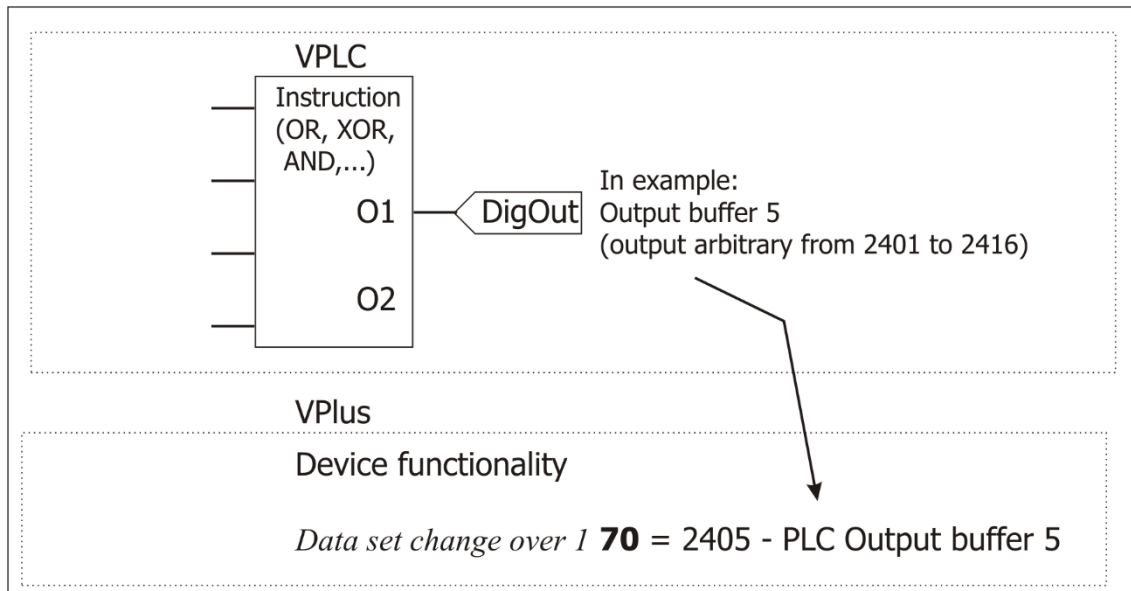

- Select an output buffer for the output of the instructions, e. g. output buffer 5. As a result, the signal source is generally (globally) available for processing by other device functions. It is also possible to choose another signal source from signal sources 2401 to 2416 for the parameter.
- For parameter *Switch Data Set 1* **70**, select signal source "2405 - FT-Output buffer 5".

Example 3: The output value of instruction 1 is to be transmitted via system bus. Depending on the device series, an extension module with system bus must be installed.

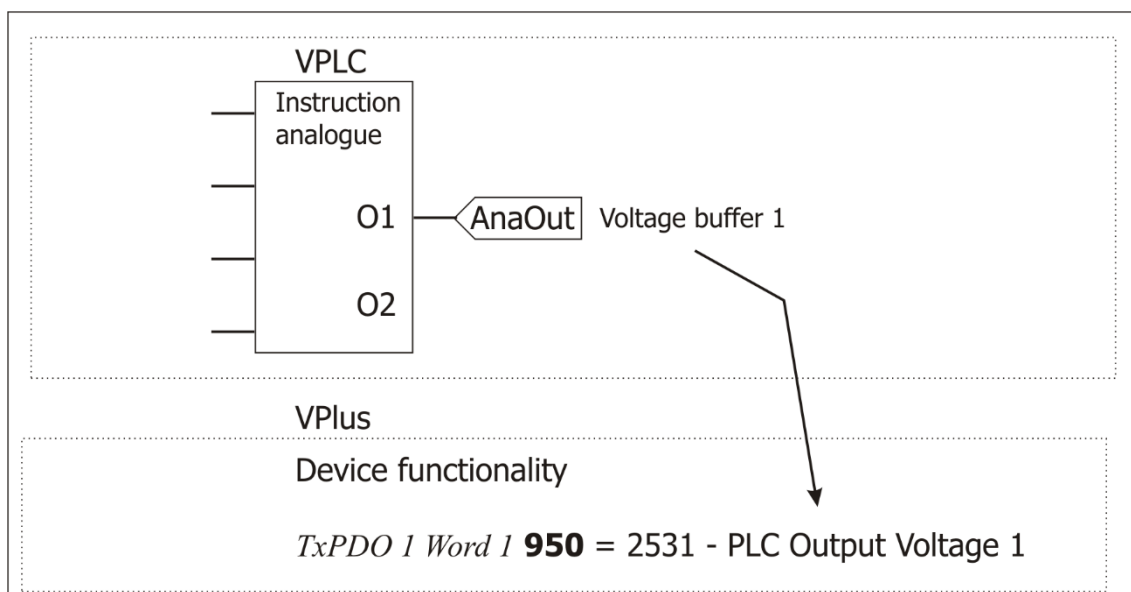

4.2.5 Controlling a digital output via the output buffer

The outputs of the instructions can be output via digital outputs once they have been defined as general (global) signal sources.

The following signal sources can be selected for the parameters of the digital outputs.

Outputs of Instructions as signal sources for digital outputs	Operation Mode Digital Output	
	Non-negated	Negated
PLC output buffer 1	80	180
PLC output buffer 2	81	181
PLC output buffer 3	82	182
PLC output buffer 4	83	183

Example: Selection of signal source for digital output:

The output signal of an instruction is to be output via a digital output.

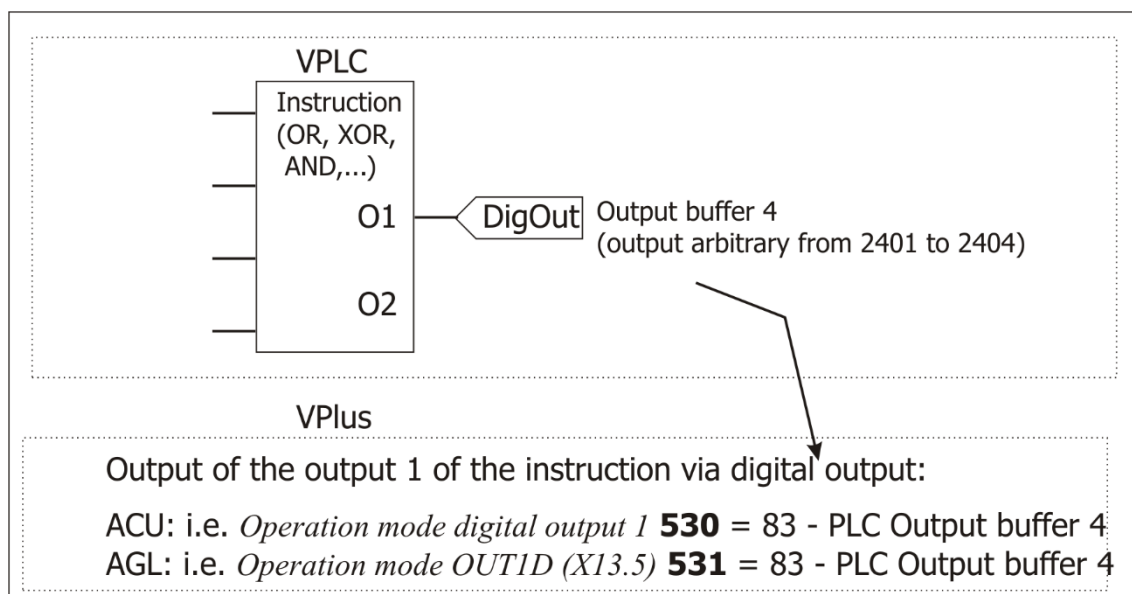

The output of the instruction must be defined as a general (global) signal source:

- Select an output buffer for the output of the instructions (e.g. 4).

As a result, the signal source is generally (globally) available for processing by other device functions and has the logic state of the output of the instruction. You can also select another output buffer.

For a digital output, choose the general (global) signal source which contains the output value of the instruction:

- For the parameter of a digital output choose the PLC output buffer signal (e.g. "83 PLC output buffer 4").

4.2.6 Controlling an analog output via the output buffer

The outputs of the analog instructions can be output via analog outputs once they have been defined as general (global) signal sources.

VPLC, AnaOut	VPlus
	Analog range 553 (ACU) Analog: <i>Source MFO1A</i> 553 (AGL)
Buffer percent Buffer number 1	61 – Abs. value PLC outp. percent 1 161 – PLC outp. percent 1
Buffer percent Buffer number 2	62 – Abs. value PLC outp. percent 2 162 – PLC outp. percent 2

Example: The output signal of an instruction is to be output via analog output MFO1A of the device.

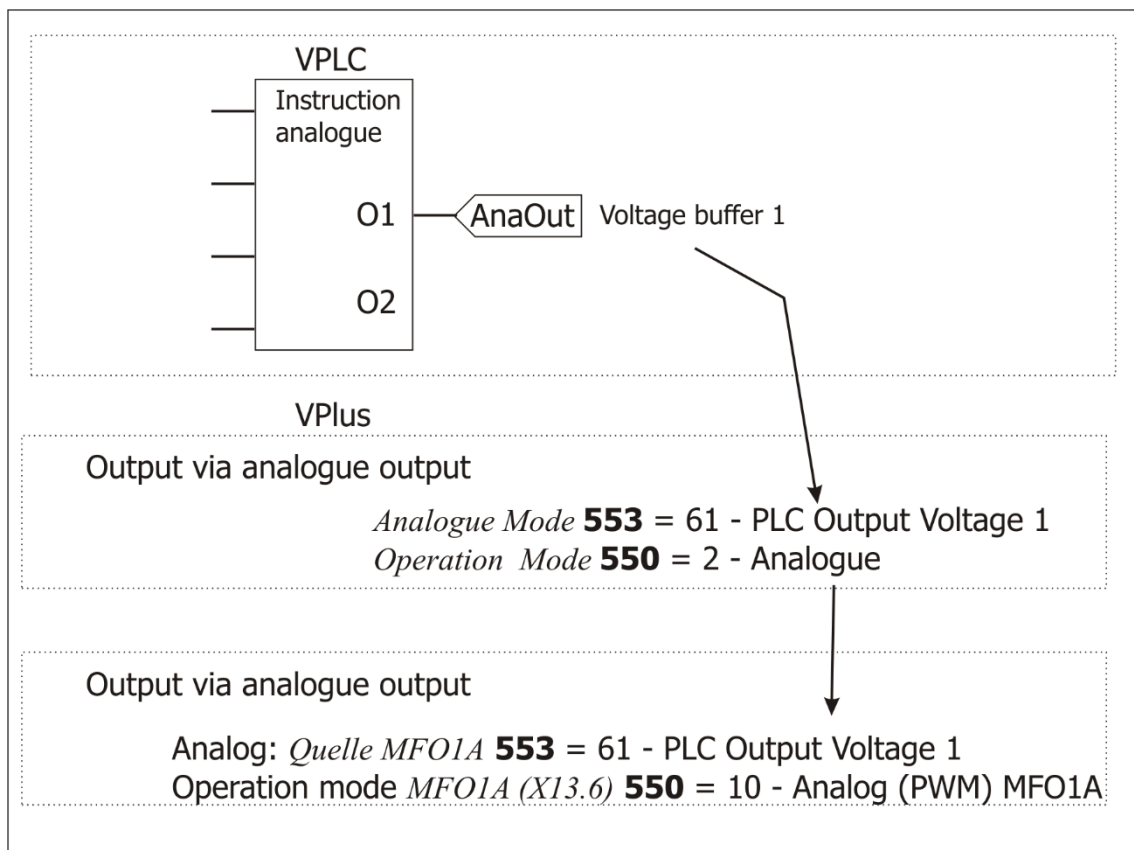

5 Description of digital functions

In the following, you will find explanations and examples of the individual digital functions. The term "digital function" is defined as follows:

A digital function has at least one digital input value but not analog input value. The output value is always digital.

The following symbols are used in the diagrams:

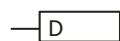
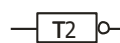
-  edge evaluation
-  level evaluation
-  negated output

- 0 "Low" state. Representation of signal statuses in logic tables.
- 1 "High" state. Representation of signal statuses in logic tables.
- FALSE "Low" state. Representation of signal statuses in function descriptions.
- TRUE "High" state. Representation of signal statuses in function descriptions.
- x any state ("Don't care" – 0 or 1).
- 0 → 1 positive edge.
- 1 → 0 negative edge.
- Q_{n-1} last state is maintained.
- $\overline{Q_{n-1}}$ last state is negated ("toggle").
- O_n non-negated output
- $\overline{O_n}$ negated output
- P1 VPLC: Input field in function block setup,
Function table: Parameter *FT Parameter 1* **1348**
- P2 VPLC: Input field in function block setup,
Function table: Parameter *FT Parameter 2* **1349**



For better clarity, output O_n (non-negated) is used in the descriptions. The negated output $\overline{O_n}$ is available in each function and can be used.

For digital functions, note:

- Unused inputs must be set to "7 - Off".
Exception: Unused inputs of the instruction "**AND**" must be set to "6 - On".
- In all functions, output 2 has the inverted logic state of input 1.
- Clock inputs (T, C) evaluate signal edges.
- Set/Superior-Set/Master-Set inputs and Reset/Superior-Reset/Master-Reset inputs evaluate logic states.
- Reset has priority over Set.
- Times set for P1 and P2, are limited internally to a max. value of 24 days.

Via the library, the logic function can be selected.

5.1 Superior/Master

Most instructions also enable setting of selective output statuses by overriding inputs. This may be used, for example, for initialization of a plant status.

There are two variants of instructions with overriding inputs.

Superior

- The function sequence is processed further internally in the instruction. The overriding inputs change the instruction output only for the time in which the overriding signal is present.
- During the set/reset phase, edges will also be detected and processed internally. If the Superior Set/Superior Reset Signal is no longer present, the output will take the value which would result without the Set/Reset Phase.
- The processing sequence can be compared to a series connection of the function and a logic AND operation with the superior inputs.

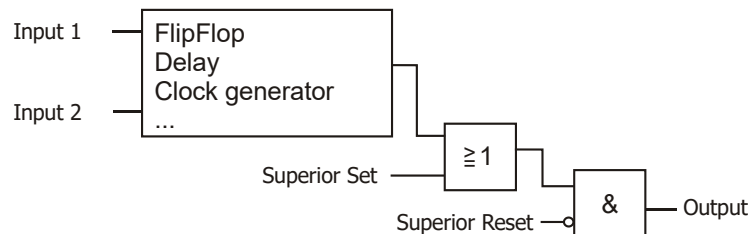

Master

- The function sequence is interrupted. The overriding inputs change the instruction output as from the time at which the overriding signal is present.
- Set/Reset signals are not evaluated as long as a Master-Set/Master-Reset is present.
- The processing sequence can be compared to a parallel connection of the function and the master inputs.

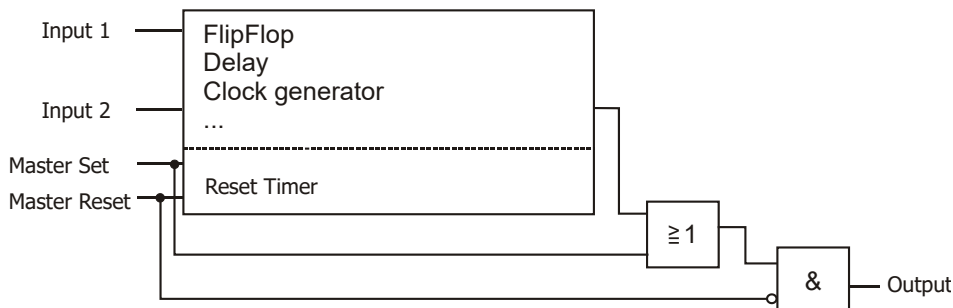

Superior

Superior-Set

Superior Reset

Master

Master-Set

Master Reset

TRUE at Superior-Set/Master-Set switches instruction output 1 to TRUE directly.

TRUE at Superior-Reset/Master-Reset switches instruction output 1 to FALSE directly. Reset has a higher priority than set.

5.2 P1 and P2 for chronological behavior and jump target

The chronological behavior of the instructions or a jump target can be set up via P1 and P2.

5.2.1 Chronological behavior

The setup of P1 and P2 affects the following instructions:

40 ... 42 / 140 ... 142 50 ... 52 / 150 ... 152	Delay
60 ... 62 / 160 ... 162 70 ... 72 / 170 ... 172	Monoflop
80 ... 82 / 180 ... 182	Clock generator

The units of P1 and P2 may be set to milliseconds [ms], seconds [s] or minutes [min]. The unit of the entered value depends on the instruction.



Time set for P1 and P2,

- are limited internally to the maximum value of 24 days
- are not continued when the frequency is switched off and on again. The sequence is restarted from the beginning after re-activation.

5.2.2 Jump target

The evaluation of P1 and P2 affects the following instruction:

100	Jump function
-----	---------------

Description	Min.	Max.
P1	1	32
P2	1	32

5.2.3 Overview table

The meaning of the settings for P1 and P2, depending on the selection of the application is summarized in the following table.

Instruction		P1	P2
40 - 140 -	delay ms (retriggerable)	delay pos. edge [ms]	delay neg. edge [ms]
41 - 141 -	delay s (retriggerable)	delay pos. edge [s]	delay neg. edge [s]
42 - 142 -	delay min (retriggerable)	delay pos. edge [min]	delay neg. edge [min]
50 - 150 -	delay ms (non-retriggerable)	delay pos. edge [ms]	delay neg. edge [ms]
51 - 151 -	delay s (non-retriggerable)	delay pos. edge [s]	delay neg. edge [s]
52 - 152 -	delay min (non-retriggerable)	delay pos. edge [min]	delay neg. edge [min]
60 - 160 -	Monoflop ms (retriggerable)	ON time [ms]	ignore edge time [ms]
61 - 161 -	Monoflop s (retriggerable)	ON time [s]	ignore edge time [s]
62 - 162 -	Monoflop min (retriggerable)	ON time [min]	ignore edge time [min]
70 - 170 -	Monoflop ms (non-retriggerable)	ON time [ms]	ignore edge time [ms]
71 - 171 -	Monoflop s (non-retriggerable)	ON time [s]	ignore edge time [s]
72 - 172 -	Monoflop min (non-retriggerable)	ON time [min]	ignore edge time [min]
80 -180 -	Clock Generator ms	ON time [ms]	OFF time [ms]
81 -181 -	Clock Generator s	ON time [s]	OFF time [s]

Instruction		P1	P2
82 - 182 -	Clock Generator min	ON time [min]	OFF time [min]
100 -	Jump function	Jump target 1	Jump target 2



Operation modes < 40 to 82 use Superior inputs, operation modes < 140 to 182 use Master inputs as overriding inputs.



In all other instructions not listed in the above table, the setting of P1 and P2 does not affect the instruction.

5.3 Boolean operations

The following table shows the logic combinations of the implemented Boolean functions. Logic 0s are indicated as dots.

Inputs				Output depending on logic function			
I1	I2	I3	I4	AND	OR	XOR 1	XOR 1 3
.
.	.	.	1	.	1	1	1
.	.	1	.	.	1	1	1
.	.	1	1	.	1	.	.
.	1	.	.	.	1	1	1
.	1	.	1	.	1	.	.
.	1	1	.	.	1	.	1
.	1	1	1	.	1	.	1
1	1	1	1
1	.	.	1	.	1	.	.
1	.	1	.	.	1	.	1
1	.	1	1	.	1	.	1
1	1	.	.	.	1	.	.
1	1	.	1	.	1	.	1
1	1	1	.	.	1	.	1
1	1	1	1	1	1	.	.

5.3.1 [1] AND operation

	Type	Function		Type	Function
I1	b	input value 1	O1	b	O1 = AND (I1 I2 I3 I4)
I2	b	input value 2	O2	b	Negated Output O2 = $\overline{O1}$
I3	b	input value 3	P1		
I4	b	input value 4	P2		

Description:

The inputs are AND-combined with one another. The inputs of the instruction are the assigned signal sources. Output is TRUE if all inputs are TRUE. As soon as one input is FALSE, the output will be FALSE. Via the output buffer, the output signal is globally available.



Unused inputs must be set to "6 - TRUE". For example, I3 and I4 must be set to "6 - TRUE" if inputs I1 and I2 are to be combined by the AND operation.

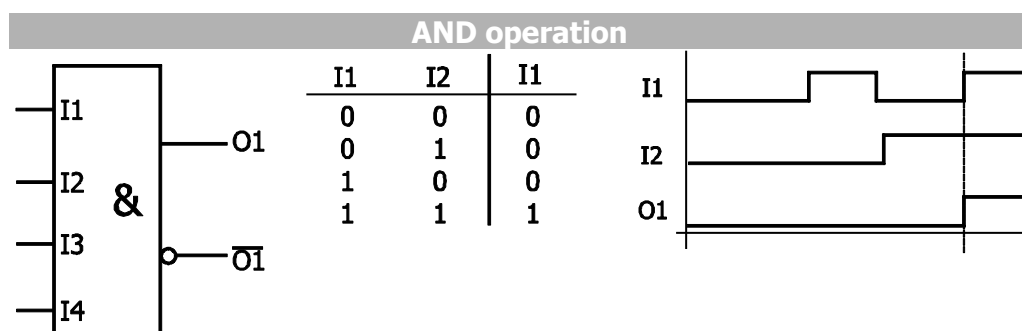

5.3.2 [2] OR operation

	Type	Function		Type	Function
I1	b	input value 1	O1	b	O1 = OR (I1 I2 I3 I4)
I2	b	input value 2	O2	b	Negated Output O2 = $\overline{O1}$
I3	b	input value 3	P1		
I4	b	input value 4	P2		

Description:

The inputs are OR-combined with one another. The inputs of the instruction are the assigned signal sources. Output is logic TRUE if at least one input is TRUE. If all inputs are FALSE, the output will be FALSE. Via the output buffer, the output signal is globally available.



Unused inputs must be set to "7 - FALSE" (factory setting). For example, I3 and I4 must be set to "7 - FALSE" if inputs I1 and I2 are to be combined by the OR operation.

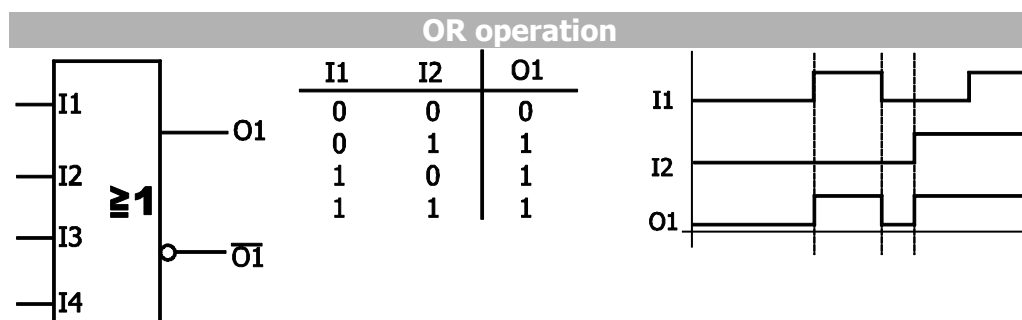

5.3.3 [3] XOR 1 operation

	Type	Function		Type	Function
I1	b	input value 1	O1	b	O1 = XOR1 (I1 I2 I3 I4)
I2	b	input value 2	O2	b	Negated Output O2 = $\overline{O1}$
I3	b	input value 3	P1		
I4	b	input value 4	P2		

Description:

The inputs are XOR-linked to one another. The inputs of the instruction are the assigned signal sources. Output is logic TRUE if exactly one input is TRUE. Via the output buffer, the output signal is globally available.

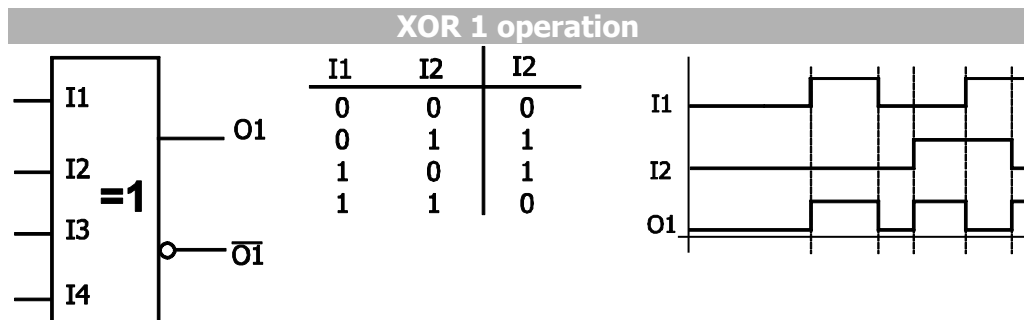

5.3.4 [4] XOR 1 | 3 operation

	Type	Function		Type	Function
I1	B	input value 1	O1	B	O1 = XOR3 (I1 I2 I3 I4)
I2	b	input value 2	O2	b	Negated Output O2 = $\overline{O1}$
I3	b	input value 3	P1		
I4	b	input value 4	P2		

Description:

The inputs are XOR-linked to one another. The inputs of the instruction are the assigned signal sources. The output is TRUE if TRUE is present on an odd number of inputs. Via the output buffer, the output signal is globally available.

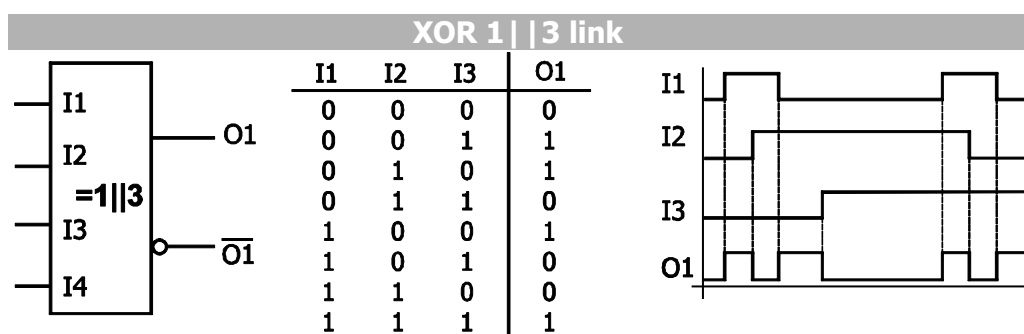

5.4 Flip-Flop types

5.4.1 [10] RS-Flip-Flop, Superior

	Type	Function		Type	Function
I1	b	Set input	O1	b	Output O1
I2	b	Reset input	O2	b	Negated Output O2 = $\overline{O1}$
I3	b	Superior Set input	P1		
I4	b	Superior Reset input	P2		

Description:

The inputs of the instruction are the assigned signal sources.

TRUE at the Set input sets the output to TRUE. TRUE at the Reset input sets the output to FALSE. If FALSE is present on both inputs, the current status of the output signal is maintained.

TRUE at the Superior Set input sets the output to TRUE. TRUE at the Superior Reset input sets the output to FALSE.

Priority:

Superior Reset (highest priority)

Superior Set

Reset

Set (lowest priority)

Via the output buffer, the output signal is globally available.

Inputs Superior Set and Superior Reset are connected in series with the function. Levels at Set input I1 and Reset input I2 are processed internally. As soon as the Superior Set or Superior Reset is reset, the output is switched to the internally saved value.

RS-Flip-Flop, Superior						
S SET	R CLR	SS	SR	Q	O1	State
x	x	X	1	0	0	Off (Superior)
X	X	1	0	1	1	On (Superior)
0	0	0	0	Q_{n-1}		Hold
0	1	0	0	0		Reset
1	0	0	0	1		Set
1	1	0	0	0		Off

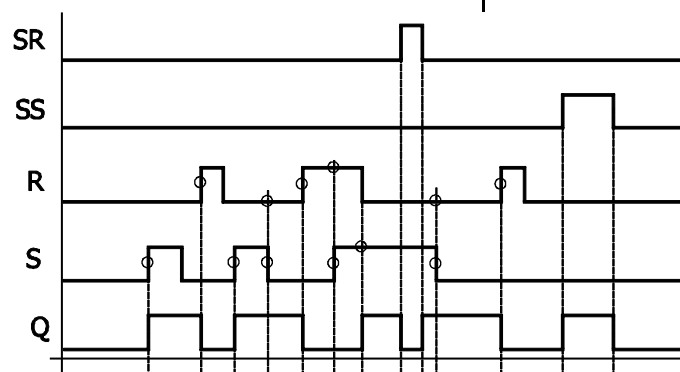

- Set: TRUE at the S input sets the output to TRUE.
- Save: If all inputs are FALSE, the output remains unchanged.
- Reset: If R input is TRUE, the output is set to logic FALSE.
- Off: If both inputs are set to TRUE, the output is FALSE.
- Superior-Set: SS, set output to TRUE.
- Superior-Reset: SR, set output to FALSE (CLR).

5.4.2 [110] RS-Flip-Flop, Master

	Type	Function		Type	Function
I1	b	Set input	O1	b	Output O1
I2	b	Reset input	O2	b	Negated Output O2 = $\overline{O1}$
I3	b	Master Set input	P1		
I4	b	Master Reset input	P2		

Description:

The inputs of the instruction are the assigned signal sources.

TRUE at the Set input sets the output to TRUE. TRUE at the Reset input sets the output to FALSE. If FALSE is present on both inputs, the current status of the output signal is maintained. TRUE at the Master Set input sets the output to TRUE. TRUE at the Master Reset input sets the output to FALSE.

Priority:

Master Reset (highest priority)

Master Set

Reset

Set (lowest priority)

Via the output buffer, the output signal is globally available.

Master Set and Master Reset are connected parallel with the function and change the state of the function as soon as the signal is present.

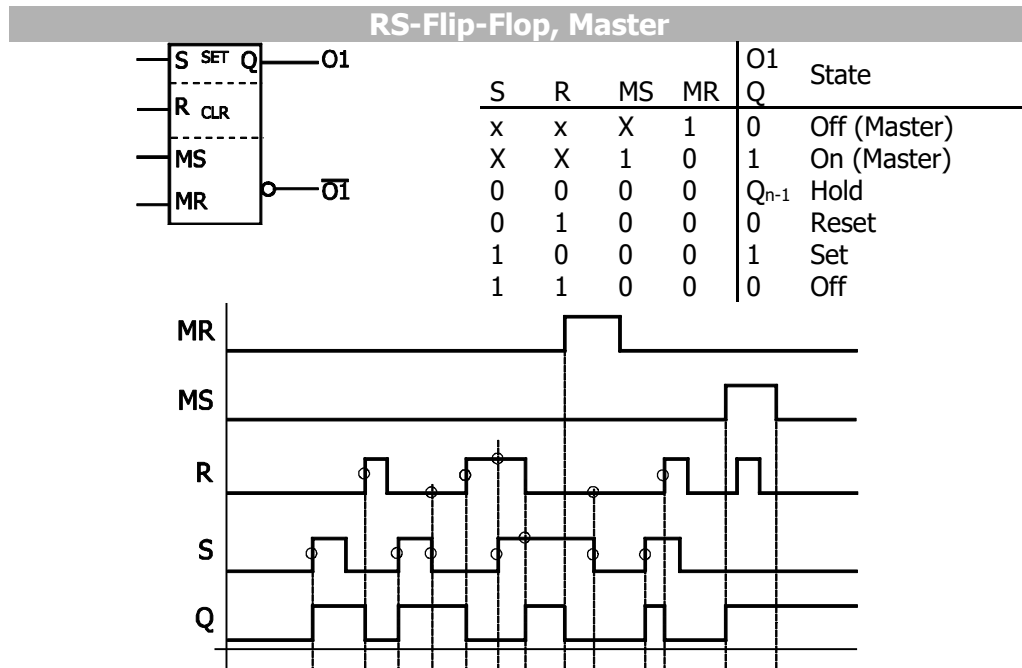

- Set: TRUE at the S input sets the output to TRUE.
- Save: If all inputs are FALSE, the output remains unchanged.
- Reset: If R input is TRUE, the output is set to logic FALSE.
- Off: If both inputs are set to TRUE, the output is FALSE.
- Master-Set: MS, set output to TRUE.
- Master-Reset: MR, set output to FALSE (CLR).

5.4.3 [20] Toggle-Flip-Flop, Superior

	Type	Function		Type	Function
I1	b	Toggle 1	O1	b	Output O1
I2	b	Toggle 2	O2	b	Negated Output O2 = $\overline{O1}$
I3	b	Superior Set input	P1		
I4	b	Superior Reset input	P2		

Description:

Output signal changes with the positive pulse edge at input T1 or with the negative pulse edge at input T2.

TRUE at the Superior Set input sets the output to TRUE. TRUE at the Superior Reset input sets the output to FALSE.

Via the output buffer, the output signal is globally available.

Inputs Superior Set and Superior Reset are connected in series with the function. Levels on T1- input I1 and T2 input I2 are processed internally. As soon as the Superior Set or Superior Reset is reset, the output is switched to the internally saved value.

Toggle-Flip-Flop, Superior					
T1	T2	SS	SR	Q	State
x	x	X	1	0	Off (Superior)
X	X	1	0	1	On (Superior)
0	0	0	0	Q_{n-1}	Hold
0	1	0	0	Q_{n-1}	Hold
0→1	x	0	0	$\overline{Q_{n-1}}$	Toggle
1	0	0	0	Q_{n-1}	Hold
1	1	0	0	Q_{n-1}	Hold
x	1→0	0	0	$\overline{Q_{n-1}}$	Toggle

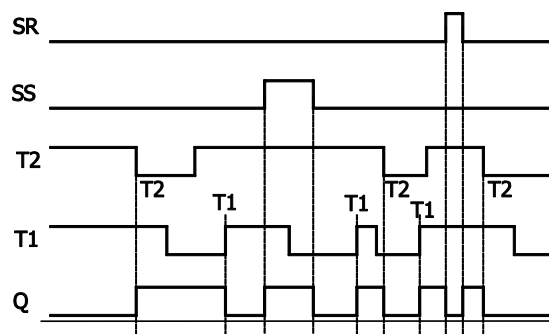
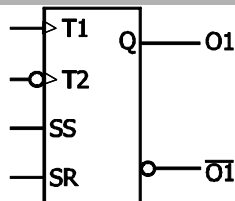

5.4.4 [120] Toggle-Flip-Flop, Master

	Type	Function		Type	Function
I1	b	Toggle 1	O1	b	Output O1
I2	b	Toggle 2	O2	b	Negated Output O2 = $\overline{O1}$
I3	b	Master Set input	P1		
I4	b	Master Reset input	P2		

Description:

Output signal changes with the positive pulse edge at input T1 or with the negative pulse edge at input T2.

TRUE at the Master Set input sets the output to TRUE. TRUE at the Master Reset input sets the output to FALSE.

Via the output buffer, the output signal is globally available.

Master Set and Master Reset are connected parallel with the function and change the state of the function as soon as the signal is present.

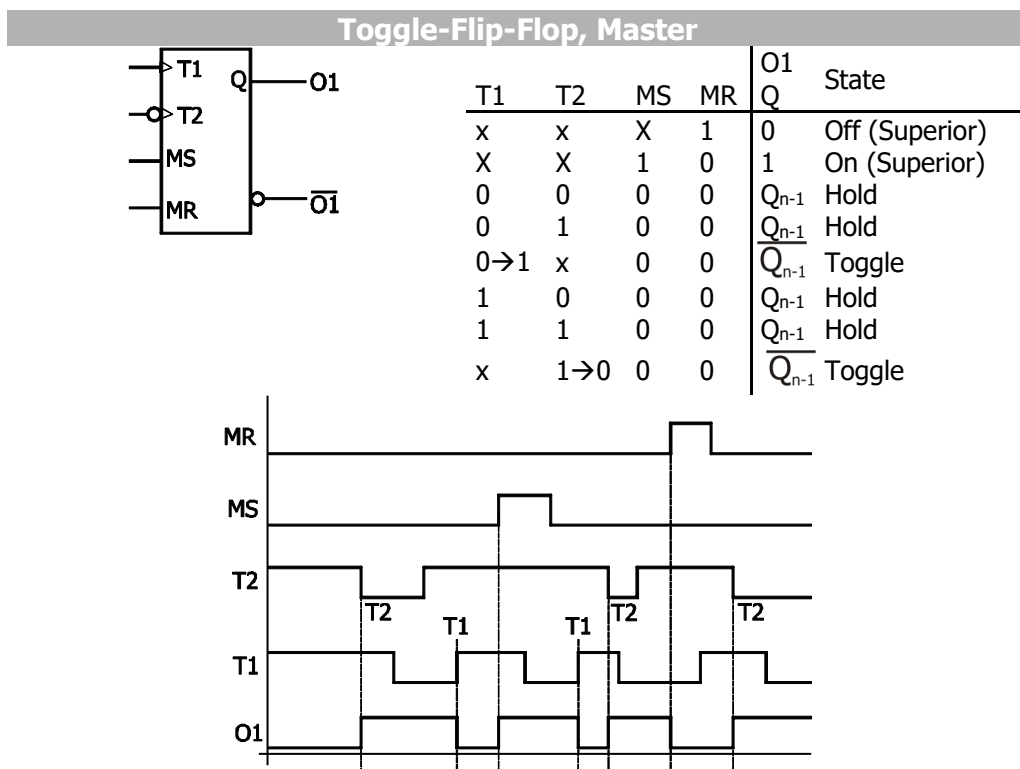

5.4.5 [30] D-Flip-Flop, Superior

	Type	Function		Type	Function
I1	b	C, Clock	O1	b	Output O1
I2	b	D, Data input	O2	b	Negated Output O2 = $\overline{O1}$
I3	b	Superior Set input	P1		
I4	b	Superior Reset input	P2		

Description:

If a positive edge is received at input 1 (clock pulse input C, Clock) the signal is transferred from signal input 2 (data input D) to the output.

TRUE at the Superior Set input sets the output to TRUE. TRUE at the Superior Reset input sets the output to FALSE.

Via the output buffer, the output signal is globally available.

Inputs Superior Set and Superior Reset are connected in series with the function. Levels on C input I1 and D input I2 are processed internally. As soon as the Superior Set or Superior Reset is reset, the output is switched to the internally saved value.

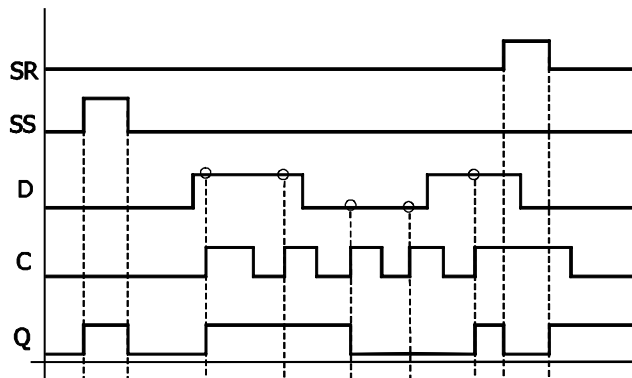
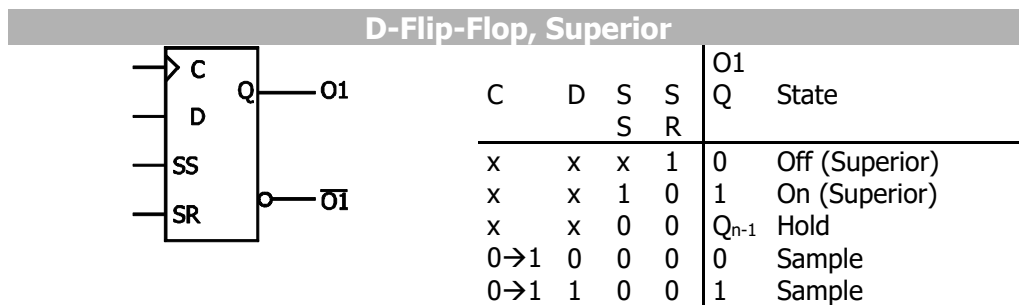

5.4.6 [130] D-Flip-Flop, Master

	Type	Function		Type	Function
I1	b	C, Clock	O1	b	Output O1
I2	b	D, Data input	O2	b	Negated Output O2 = $\overline{O1}$
I3	b	Master Set input	P1		
I4	b	Master Reset input	P2		

Description:

If a positive edge is received at input 1 (clock pulse input C, Clock) the signal is transferred from signal input 2 (data input D) to the output.

TRUE at the Master Set input sets the output to TRUE. TRUE at the Master Reset input sets the output to FALSE.

Via the output buffer, the output signal is globally available.

Master Set and Master Reset are connected parallel with the function and change the state of the function as soon as the signal is present.

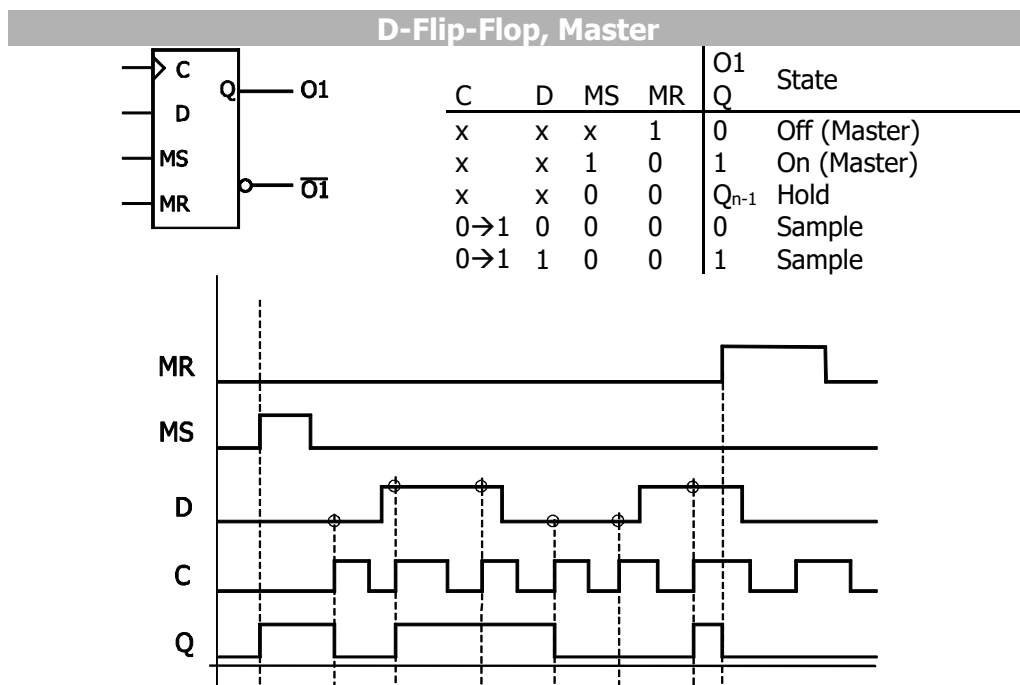

5.5 Delays

The delays can be used for delaying edges for a certain time. Two separate timers are available for the rising and the falling edge.

If the delay times are different, this may result in an edge F1 at time T_{11} has a later switching time T_{12} than an edge F2 at the time T_{21} with switching time T_{22} . In this case, no edge is switched at the output, as this would result in the input and output being inverted to on another.

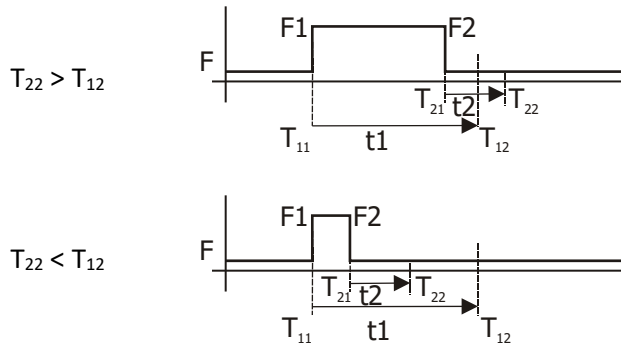

The delays are implemented both as "retriggerable" and as "non-retriggerable".

Retriggerable means that a new edge (with the same direction) during the processing will restart the delay, the switching time for the edge will be recalculated ("last edge dominant"). The level of the input and output are not relevant to the calculation of the switching times.

Retriggerable should be selected if, in the case of several consecutive signals with a short interval between them, only the last signal is to be executed, or if, in the case of continuous signals, brief signal disturbances (flickering) are to be filtered out. The level of the input and output are not relevant to the calculation of the switching times.

Non-retriggerable means that a new edge (with the same direction) during the processing will not restart the delay, the originally calculated switching time is maintained ("first edge dominant").

Non-retriggerable should be used if an edge is to start a process, and the process should not be stopped before the end of the delay.



The units of the set times is milliseconds [ms], seconds [s] or minutes [min]. Internally, the values for delays are limited to 24 days.

Example 1

1 square pulse

On time input (F): 500 ms
 Delay, positive edge: 1000 ms
 Delay, negative edge: 800 ms

non-retriggerable

retriggerable

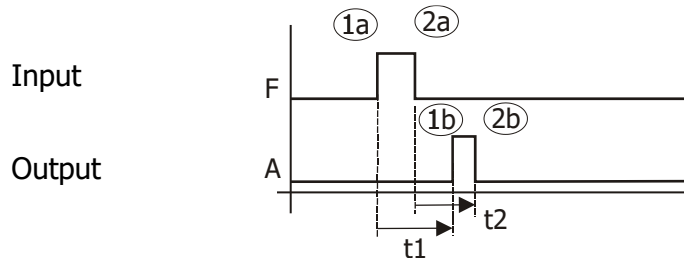

Edge 1a starts timer t1

Edge 2a starts timer t2

Edge 1b is output after a delay of t1 (referred to 1a)

Edge 2b is output after a delay of t2 (referred to 2a)

Example 2

1 square pulse followed by positive edge

On time input (F): 500 ms
 Off time input (F): 350 ms
 Delay, positive edge: 1000 ms
 Delay, negative edge: 800 ms

non-retriggerable

retriggerable

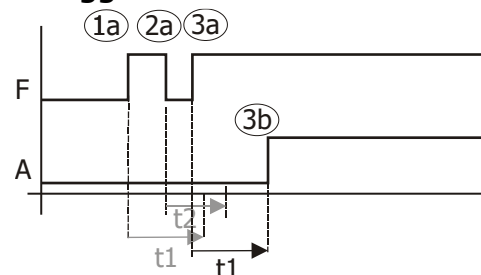
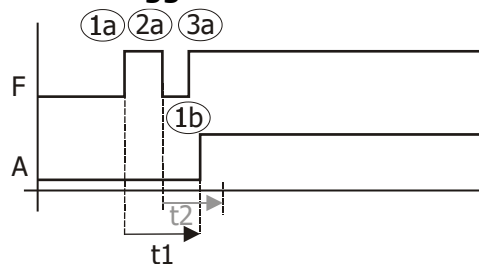

1a starts timer t1

2a starts timer t2

1b is output after t1

3a (continuous signal) stops execution of 2a

1a starts timer t1

2a starts timer t2

3a starts timer t1 again (retrigger)

3b is output after t1 (referred to 3a)

Example 3

4 consecutive square pulses

On times and delays as in example 2

non-retriggerable

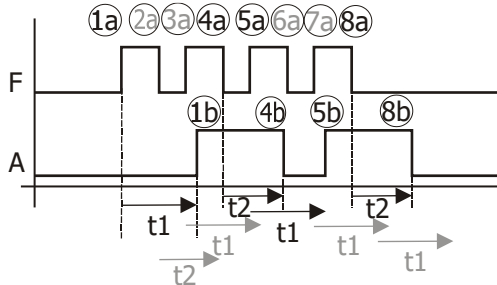

- 1a starts timer t1
- 2a starts timer t2
- 3a stops execution of 2a
- 1b is output after time t1
- 4a starts timer t2
- 5a starts timer t1
- 4b is output after time t2
- 6a to 8b: repeated as from 2a

retriggerable

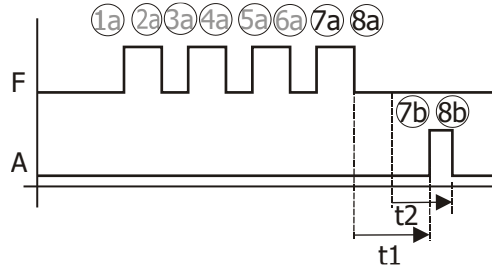

- 1a starts timer t1
- 2a starts timer t2
- 3a starts timer t1 again (retrigger)
- 4a starts timer t2 again (retrigger)
- 5a...10a restart timer t1 and t2
- 9b is output after t1 (referred to 9a)

Example 4

3 consecutive square pulse followed by positive edge

On times and delays as in example 2

non-retriggerable

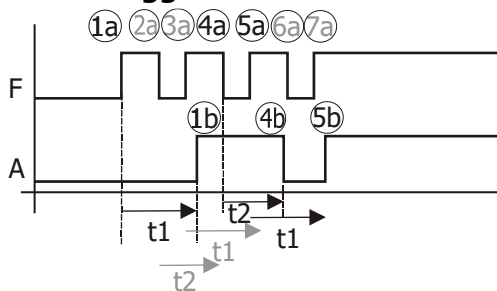

Processing as in example 3. Edge 5a switches output "High". Edges 6a and 7a are filtered out due to the quick succession.

retriggerable

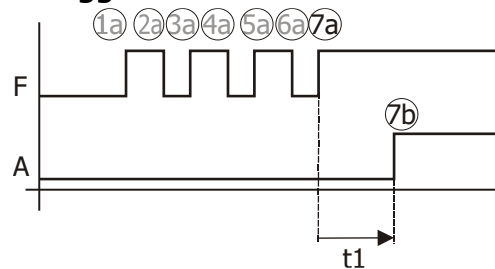

Processing as in example 3. The last positive edge (7a) maintains the output signals on "High" level.

5.5.1 [40, 41, 42] Delay (retriggerable), Superior

	Type	Function		Type	Function
I1	b	F, edge	O1	b	Output O1
I2	b		O2	b	Negated Output O2 = $\overline{O1}$
I3	b	Superior Set input	P1		On delay t1
I4	b	Superior Reset input	P2		Off delay t2

Description:

The positive edge at input 1 is transferred to the output after delay t1, the negative edge after delay t2. The delay time starts again with each edge.

TRUE at the Superior Set input sets the output to TRUE. TRUE at the Superior Reset input sets the output to FALSE.

Via the output buffer, the output signal is globally available.

Inputs Superior Set and Superior Reset are connected in series with the function. Levels at input I1 are processed internally. As soon as the Superior Set or Superior Reset is reset, the output is switched to the internally saved value.

Delay Superior (retriggerable), Superior

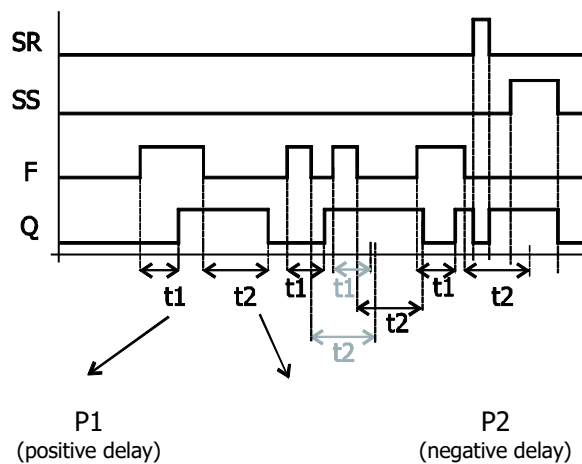
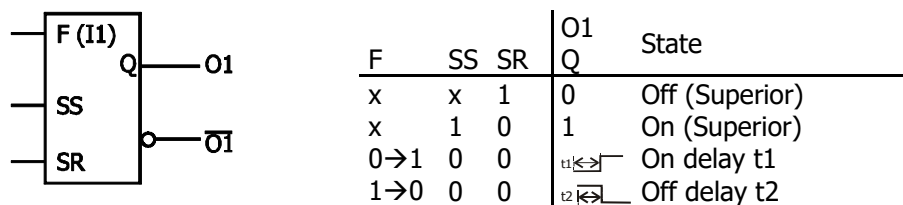

5.5.2 [140, 141, 142] Delay (retriggerable), Master

	Type	Function		Type	Function
I1	b	F, edge	O1	b	Output O1
I2	b		O2	b	Negated Output O2 = $\overline{O1}$
I3	b	Master Set input	P1		On delay t1
I4	b	Master Reset input	P2		Off delay t2

140 [ms], 141 [s] or 142 [min]

Description:

The positive edge at input 1 is transferred to the output after delay t1 (P1), the negative edge after delay t2 (P2). The delay time starts again with each edge.

TRUE at the Master Set input sets the output to TRUE. TRUE at the Master Reset input sets the output to FALSE.

Via the output buffer, the output signal is globally available.

Master Set and Master Reset are connected parallel with the function and change the state of the function as soon as the signal is present.

Delay (retriggerable), Master

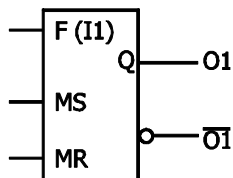

F	MS	MR	O1 Q	State
x	x	1	0	Off (Master)
x	1	0	1	On (Master)
0 → 1	0	0	t_1	On delay t1
1 → 0	0	0	t_2	Off delay t2

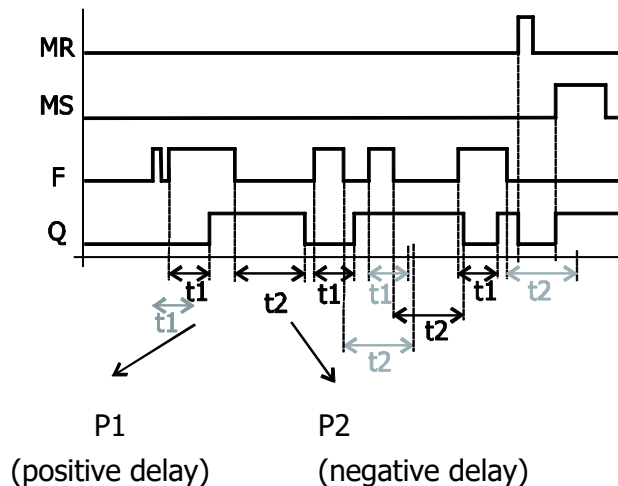

5.5.3 [50, 51, 52] Delay (non-retriggerable), Superior

	Type	Function		Type	Function
I1	b	F, edge	O1	b	Output O1
I2	b		O2	b	Negated Output O2 = $\overline{O1}$
I3	b	Superior Set input	P1		On delay t1
I4	b	Superior Reset input	P2		Off delay t2

50 [ms], 51 [s] or 52 [min]

Description:

The positive edge at input 1 is transferred to the output after delay t1 (P1), the negative edge after delay t2 (P2). The delay time starts again with each edge.

TRUE at the Superior Set input sets the output to TRUE. TRUE at the Superior Reset input sets the output to FALSE.

Via the output buffer, the output signal is globally available.

Inputs Superior Set and Superior Reset are connected in series with the function. Levels at input I1 are processed internally. As soon as the Superior Set or Superior Reset is reset, the output is switched to the internally saved value.

Delay (non-retriggerable), Superior

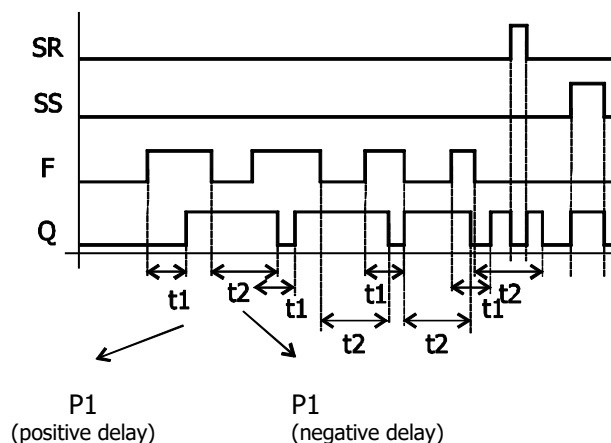
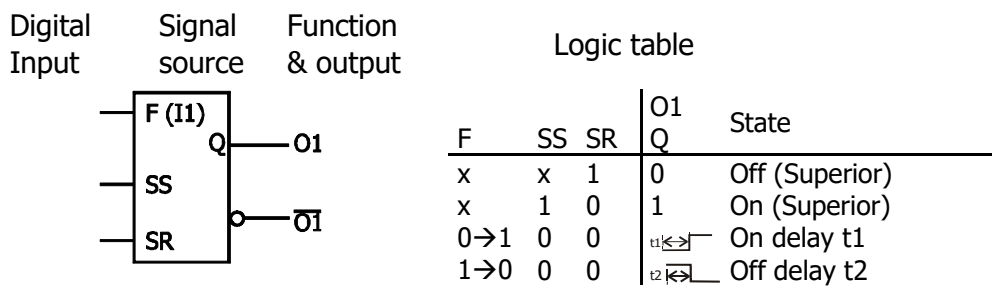

5.5.4 [150, 151, 152] Delay (non-retriggerable), Master

	Type	Function		Type	Function
I1	b	F, edge	O1	b	Output O1
I2	b		O2	b	Negated Output O2 = $\overline{O1}$
I3	b	Master Set input	P1		On delay t1
I4	b	Master Reset input	P2		Off delay t2

150 [ms], 151 [s] or 152 [min]

Description:

The positive edge at input 1 is transferred to the output after delay t1 (P1), the negative edge after delay t2 (P2). The delay time starts again with each edge.

TRUE at the Master Set input sets the output to TRUE. TRUE at the Master Reset input sets the output to FALSE.

Via the output buffer, the output signal is globally available.

Master Set and Master Reset are connected parallel with the function and change the state of the function as soon as the signal is present.

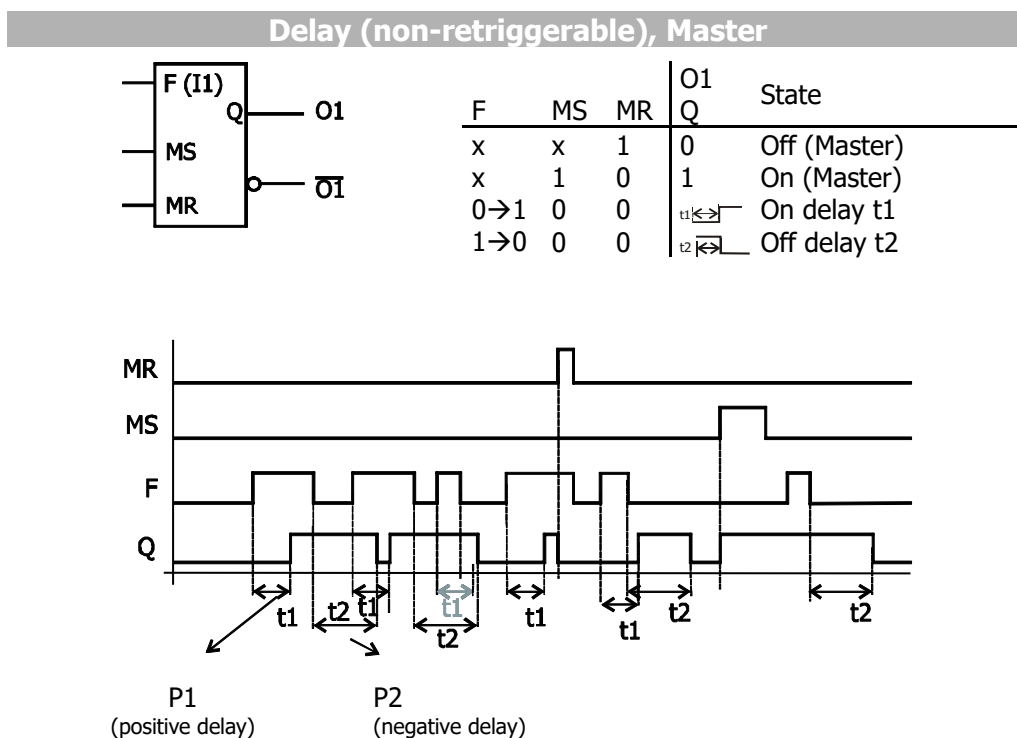

5.6 Timer functions

5.6.1 [60, 61, 62] Monoflop (retriggerable), Superior

	Type	Function		Type	Function
I1	b	M, Monoflop edge 1	O1	b	Output O1
I2	b	\bar{M} , Monoflop edge 2	O2	b	Negated Output O2 = $\overline{O1}$
I3	b	Superior Set input	P1		On-time (High)
I4	b	Superior Reset input	P2		Ignore edge time

60 [ms], 61 [s] or 62 [min]

Description:

Output signal becomes TRUE with positive clock edge at input 1 or with negative clock edge at input 2. The time set in P1 is the On-Time (High) and the time set in P2 is the ignore edge time (Low). The set on-time starts again with each edge.

TRUE at the Superior Set input sets the output to TRUE. TRUE at the Superior Reset input sets the output to FALSE.

Via the output buffer, the output signal is globally available.

Inputs Superior Set and Superior Reset are connected in series with the function. Levels on Monoflop inputs I1 and I2 As soon as the Superior Set or Superior Reset is reset, the output is switched to the internally saved value.

Monoflop (retriggerable), Superior

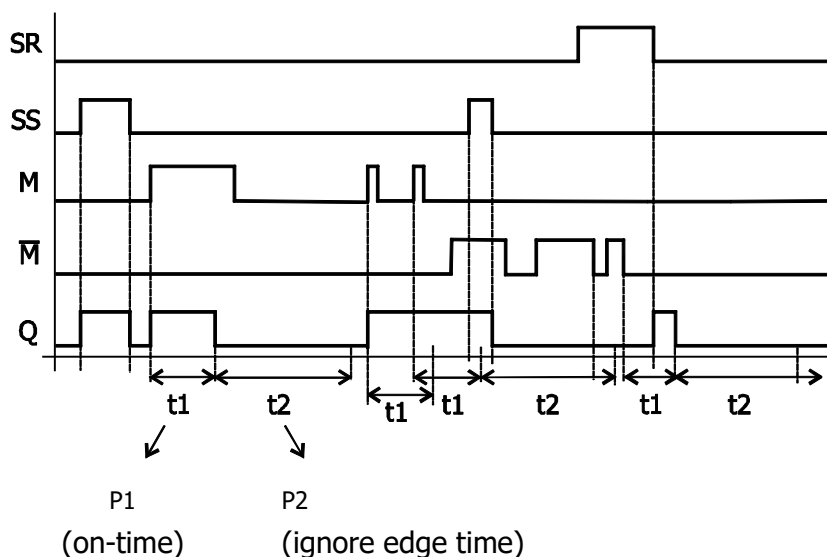
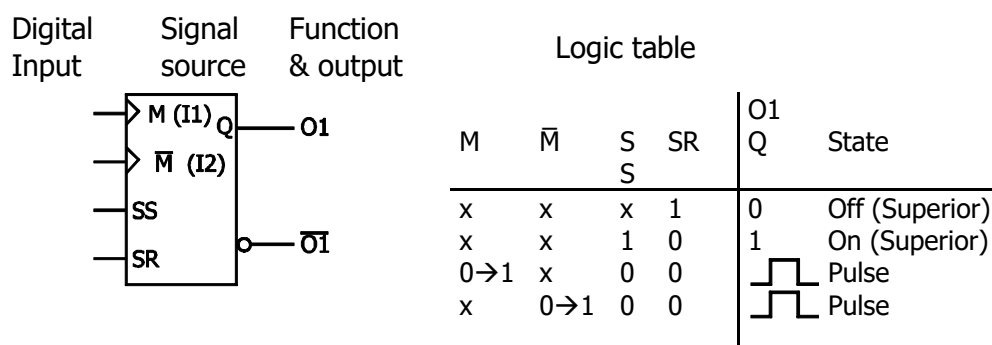

5.6.2 [160, 161, 162] Monoflop (retriggerable), Master

	Type	Function		Type	Function
I1	b	M, Monoflop edge 1	O1	b	Output O1
I2	b	\bar{M} , Monoflop edge 2	O2	b	Negated Output O2 = $\overline{O1}$
I3	b	Master Set input	P1		On-time (High)
I4	b	Master Reset input	P2		Ignore edge time

160 [ms], 161 [s] or 162 [min]

Description:

Output signal becomes TRUE with positive clock edge at input 1 or with negative clock edge at input 2. The time set in P1 is the On-Time (High) and the time set in P2 is the ignore edge time (Low). The set on-time starts again with each edge.

TRUE at the Master Set input sets the output to TRUE. TRUE at the Master Reset input sets the output to FALSE.

Via the output buffer, the output signal is globally available.

Master Set and Master Reset are connected parallel with the function and change the state of the function as soon as the signal is present.

Monoflop (retriggerable), Master

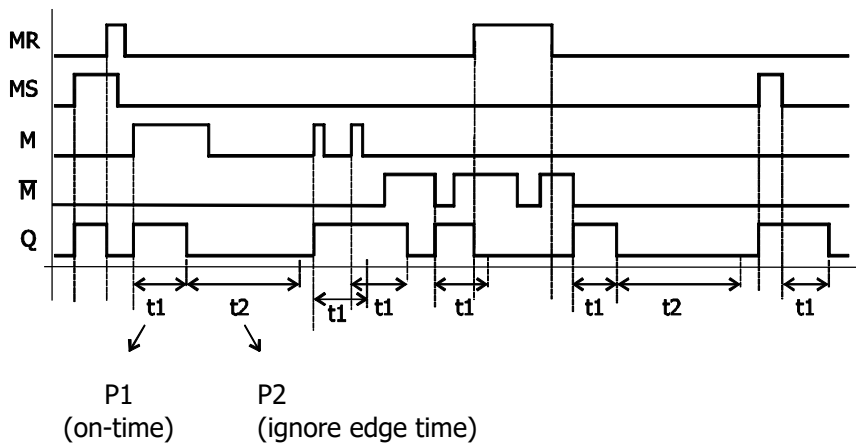
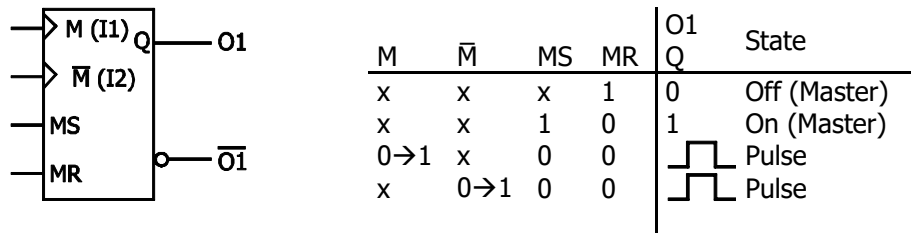

5.6.3 [70, 71, 72] Monoflop (non-retriggerable), Superior

	Type	Function		Type	Function
I1	b	M, Monoflop edge 1	O1	b	Output O1
I2	b	\bar{M} , Monoflop edge 2	O2	b	Negated Output O2 = $\overline{O1}$
I3	b	Superior Set input	P1		On-time (High)
I4	b	Superior Reset input	P2		Ignore edge time

70 [ms], 71 [s] or 72 [min]

Description:

Output signal becomes TRUE with positive clock edge at input 1 or with negative clock edge at input 2. The time set in P1 is the On-Time (High) and the time set in P2 is the ignore edge time (Low). The set on-time starts again with each edge.

TRUE at the Superior Set input sets the output to TRUE. TRUE at the Superior Reset input sets the output to FALSE.

Via the output buffer, the output signal is globally available.

Inputs Superior Set and Superior Reset are connected in series with the function. Levels on Monoflop inputs I1 and I2 As soon as the Superior Set or Superior Reset is reset, the output is switched to the internally saved value.

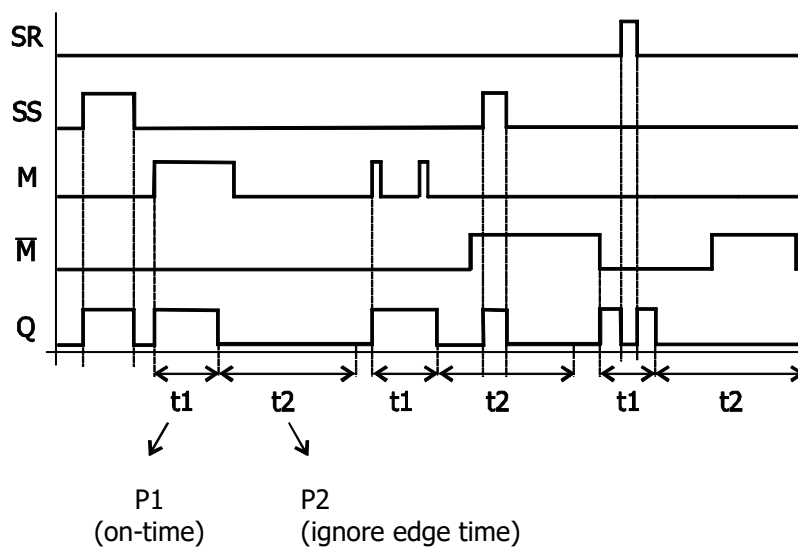
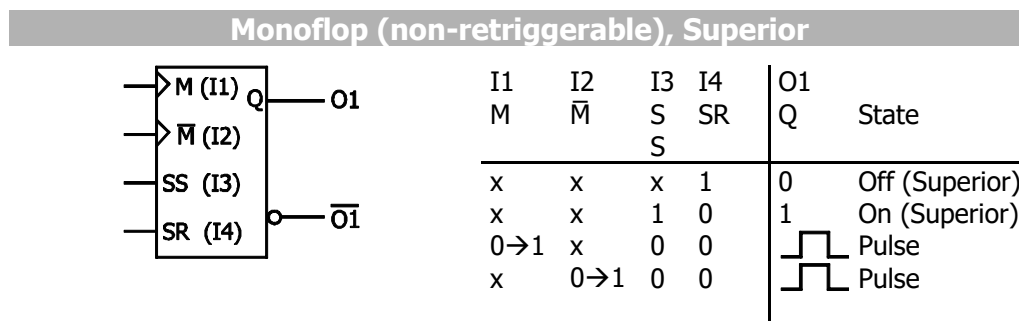

5.6.4 [170, 171, 172] Monoflop (non-retriggerable), Master

	Type	Function		Type	Function
I1	b	M, Monoflop edge 1	O1	b	Output O1
I2	b	\bar{M} , Monoflop edge 2	O2	b	Negated Output O2 = $\overline{O1}$
I3	b	Master Set input	P1		On-time (High)
I4	b	Master Reset input	P2		Ignore edge time

170 [ms], 171 [s] or 172 [min]

Description:

Output signal becomes TRUE with positive clock edge at input 1 or with negative clock edge at input 2. The time set in P1 is the On-Time (High) and the time set in P2 is the ignore edge time (Low). The set on-time starts again with each edge.

TRUE at the Master Set input sets the output to TRUE. TRUE at the Master Reset input sets the output to FALSE.

Via the output buffer, the output signal is globally available.

Master Set and Master Reset are connected parallel with the function and change the state of the function as soon as the signal is present.

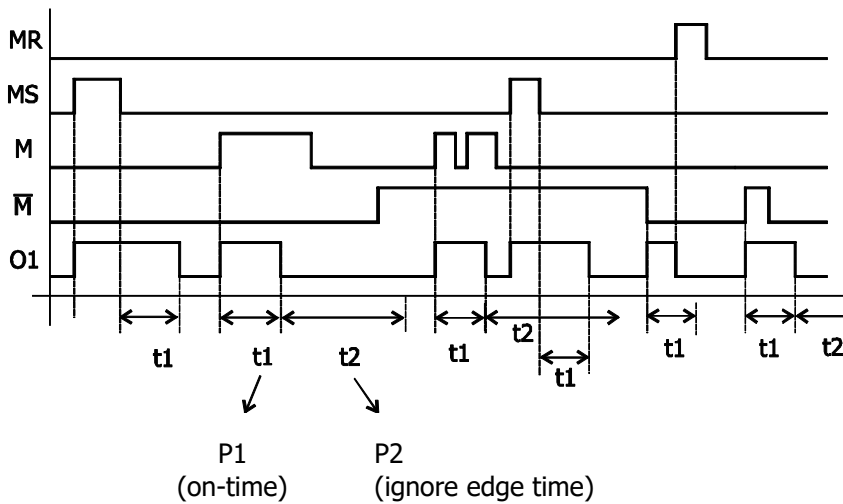
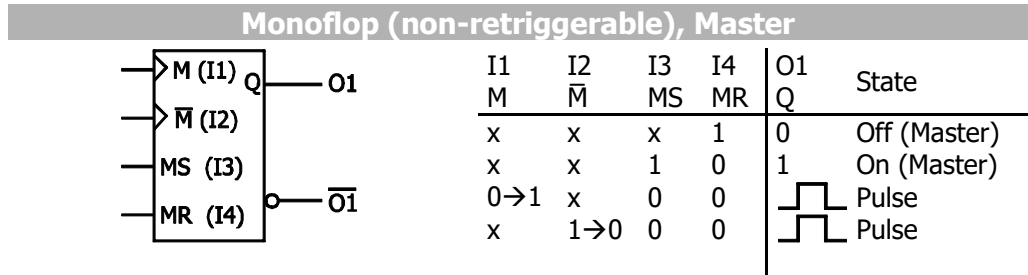

5.6.5 [80, 81, 82] Clock generator Superior

	Type	Function		Type	Function
I1	b	S clock generator 1	O1	b	Output O1
I2	b	\bar{S} clock generator 2	O2	b	Negated Output O2 = $\overline{O1}$
I3	b	Superior Set input	P1		On-time (High)
I4	b	Superior Reset input	P2		Off time (Low)

80 [ms], 81 [s] or 82 [min]

Description:

As long as input 1 is TRUE and input 2 is FALSE, the set pulse pattern is output. The pulse pattern at the output always starts with TRUE. The clock pattern is defined by the on-time and the off-time. The time set in P1 is the on-time (High) and the time set in P2 is the off-time (Low).

Via the output buffer, the output signal is globally available.

Inputs Superior Set and Superior Reset are connected in series with the function. Levels at Set input I1 and Reset input I2 are processed internally. As soon as the Superior Set or Superior Reset is reset, the output is switched to the internally saved value.

Clock generator

S (I1)	\bar{S} (I2)	SS	SR	O1 Q	State
x	x	x	1	0	Off (Superior)
x	X	1	0	1	On (Superior)
x	1	0	0	0	Off
0	x	0	0	0	Off
1	0	0	0	t	1 Clock On
				1	
1	0	0	0	t	0 Clock Off
				2	

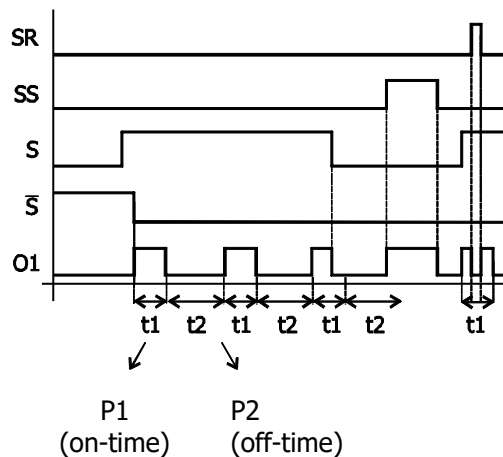

5.6.6 [180, 181, 182] Clock generator, Master

	Type	Function		Type	Function
I1	b	S clock generator 1	O1	b	Output O1
I2	b	\bar{S} clock generator 2	O2	b	Negated Output O2 = $\overline{O1}$
I3	b	Master Set input	P1		On-time (High)
I4	b	Master Reset input	P2		Off time (Low)

180 [ms], 181 [s] or 182 [min]

Description:

As long as input 1 is TRUE and input 2 is FALSE, the set pulse pattern is output. The pulse pattern at the output always starts with TRUE. The clock pattern is defined by the on-time and the off-time. The time set in P1 is the on-time (High) and the time set in P2 is the off-time (Low).

Via the output buffer, the output signal is globally available.

Master Set and Master Reset are connected parallel with the function and change the state of the function as soon as the signal is present.

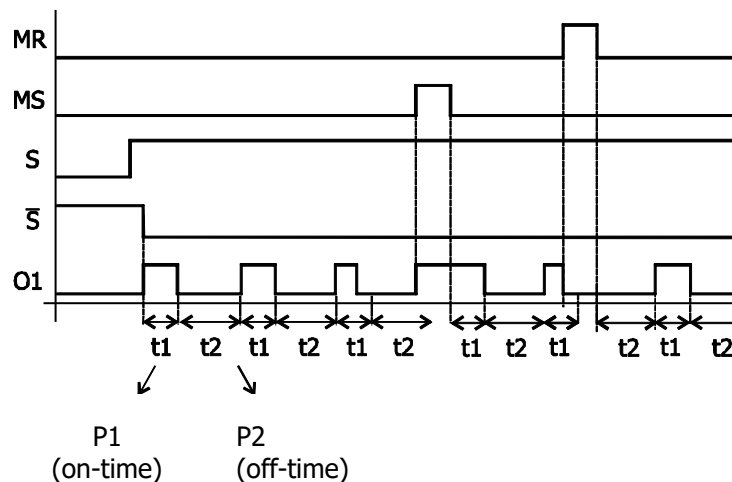
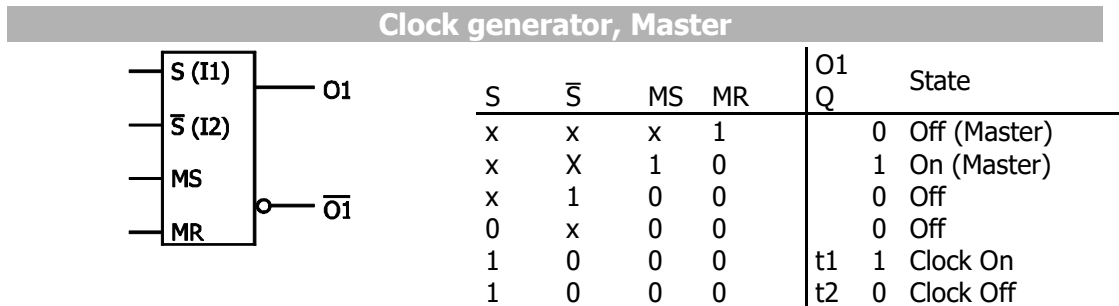

5.7 Digital multiplexer

5.7.1 [90] Digital Multiplexer (Data Set Number)

	Type	Function		Type	Function
I1	b	Input data set 1	O1	b	Output O1
I2	b	Input data set 2	O2	b	Negated Output O2 = $\overline{O1}$
I3	b	Input data set 3	P1		
I4	b	Input data set 4	P2		

Description:

Depending on the current data set, the input values are forwarded to the outputs .

Parameter *Active data set* **249** shows the selected data set.

Digital Multiplexer (Data Set Number)

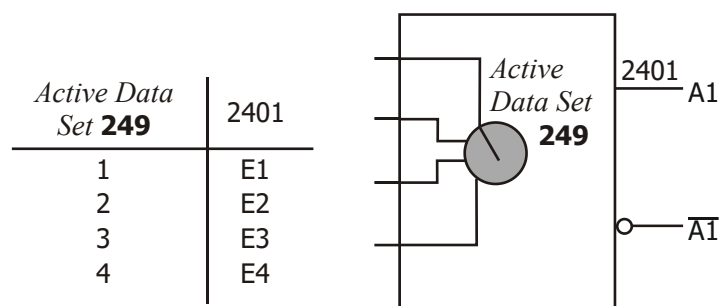

5.8 Switch

5.8.1 [91] Switch Data Set

	Type	Function		Type	Function
I1	b	Input 1 (highest priority)	O1	-	-
I2	b	Input 2	O2	-	-
I3	b	Input 3	P1	-	-
I4	b	Input 4 (lowest priority)	P2	-	-

Description:

A data set is selected via the input values.

Switch data set

I1	I2	I3	I4	Data Set
1	x	x	x	1
0	1	x	x	2
0	0	1	x	3
0	0	0	1	4
0	0	0	0	Data set via contacts

5.9 Error functions

5.9.1 [95] Triggering of an error

	Type	Function		Type	Function
I1	b	Triggering user error 1	O1	-	-
I2	b	Triggering user error 2	O2	-	-
I3	b	Triggering user error 3	P1	i	Shut-down behavior
I4	b	Triggering user error 4	P2	-	-

Description:

If one of the inputs is TRUE, the relevant user error is triggered. The output stages are disabled. The error is not acknowledgeable as long the input remains TRUE.

The function can be used, for example, for stopping the drive by external events.

Via P1, the shut-down behavior can be adjusted. The error cut-off can be effected immediately, or the drive can be shut down first.

- P1 = 0: No error cut-off (deactivated)
- P1 = 1: Shut-down and error cut-off.
- P1 = 2: Emergency stop and error cut-off.
- P1 = 3: Error cut-off immediately.

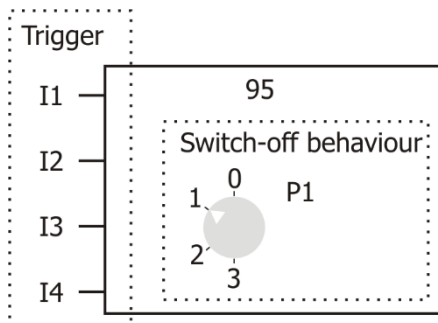

Value	Logic state				Trigger User error	Function
	I1	I2	I3	I4		
"0"	1	0	0	0	1	No error cut-off
	0	1	0	0	2	
	0	0	1	0	3	
	0	0	0	1	4	
"1"	1	0	0	0	1	Shut-down and error cut-off
	0	1	0	0	2	
	0	0	1	0	3	
	0	0	0	1	4	
"2"	1	0	0	0	1	Emergency stop and error cut-off
	0	1	0	0	2	
	0	0	1	0	3	
	0	0	0	1	4	
"3"	1	0	0	0	1	Error cut-off immediately
	0	1	0	0	2	
	0	0	1	0	3	
	0	0	0	1	4	

One of the following error messages is displayed after a user error was triggered:

Error	Description
F3031	User error 1 PLC
F3032	User error 2 PLC
F3033	User error 3 PLC
F3034	User error 4 PLC

The inputs are evaluated with priority I1, I2, I3, I4. For example, I1 has priority over I2 if both inputs are TRUE.

5.9.2 [96] Acknowledging an error

	Type	Function		Type	Function
I1	b	Input error reset +	O1	b	"Message can be acknowledged".
I2	b	Input error reset -	O2	b	inverted output = O1
I3	-	-	P1	-	-
I4	-	-	P2	-	-

Description:

Output 1 becomes TRUE if an acknowledgeable error message is present.

With each positive edge at input 1 or negative edge at input 2 an attempt is made to acknowledge a present error message. If the message cannot be acknowledged (yet), there is no reaction.

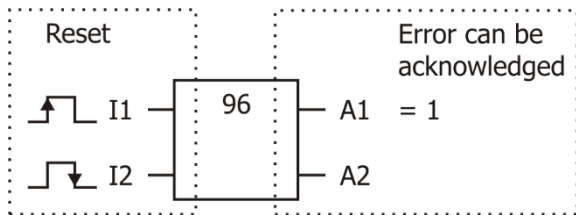

O1	I1	I2	Function
1	0→1	x	Acknowledge fault.
0			None
1	x	1→0	Acknowledge fault.
0			None
I1	x	x	Automatic Error Acknowledgment



If output 1 is connected with input 1, faults are acknowledged automatically.

5.10 Debouncer

5.10.1 [97] Debouncer

	Type	Function		Type	Function
I1	b	input value 1	O1	b	O1 = Debounced input value 1
I2	b	-	O2	b	Negated Output O2 = $\overline{O1}$
I3	b	Master Set	P1		delay positive edge in ms
I4	b	Master Reset	P2		delay negative edge in ms

Description:

The input value will be forwarded to the output only if it has had a constant value for the configured delay.

The delay for the positive edge of the input signal can be set via P1. The delay for the negative edge of the input signal can be set via P2.

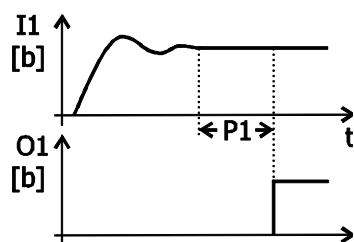

Master Set: TRUE at I3 sets O1 to TRUE.

Master-Reset: TRUE at I4 sets O1 to FALSE.

Master Reset has priority over Master Set.

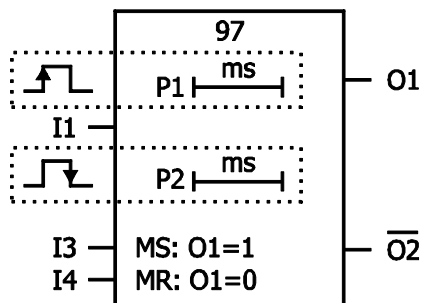

5.11 No operation

5.11.1 [99] NOP (no operation)

Description:

This function can be used as a placeholder if it is expected that function will be added to the programming later. It does not carry out an operation.

5.12 Jump functions

5.12.1 [100] Jump function

	Type	Function		Type	Function
I1	b	Jump function active	O1		
I2	b	Jump target P1/P2	O2		
I3	b	Update input buffer	P1	i	Jump target P1
I4	b	Update output buffer	P2	i	Jump target P2

Description:

This function enables jumps in the sequence of the instructions to other instructions.

Activation

Input 1 activates the jump function

Input 1 = TRUE: jump function is executed

Input 1 = FALSE: jump function is not executed

Jump target

Input 2 defines the jump target of which parameter – P1 or P2 – is to be applied.

Input 2 = TRUE: Jump to instruction set in P1.

Input 2 = FALSE: Jump to instruction set in P2.

Updating of input buffer

TRUE at input 3 results in the input buffer being updated. The values of the digital inputs and signal sources in the input buffer are updated.

Updating of output buffer (output buffer values)

TRUE at input 4 results in the values of the output values "2401 - PLC output buffer 1" to "2416 - PLC output buffer 16" being updated. The updated values are available to digital outputs and functions linked to instruction outputs (e.g. Start Clockwise, Switch Data Set).

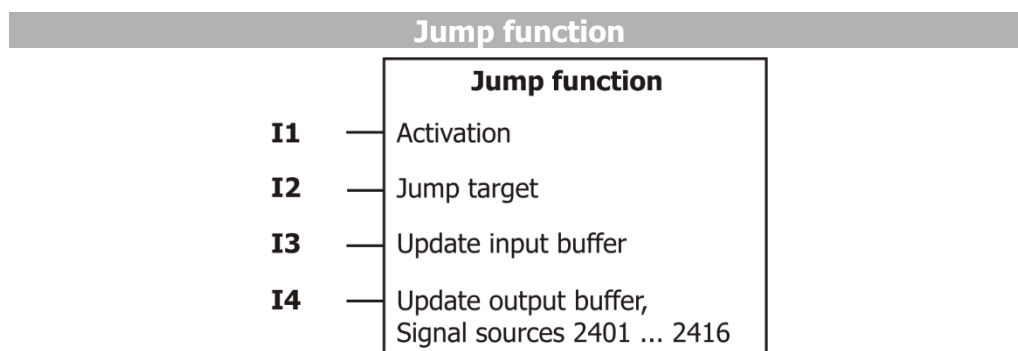

I1	I2	I3	I4	Jump
0	x	x	x	Jump to next instruction (index I + 1)
1	1	x	x	Jump to instruction set in P1.
1	0	x	x	Jump to instruction set in P2.
I1	I2	I3	I4	Update
x	x	1	x	Update input buffer (2001 ... 2016).
x	x	x	1	Update output buffer (2401 ... 2416).



At first, the output buffer is written and the input buffer is set. Then, the jump event is evaluated (based on the updated buffers) and executed.

5.12.2 [101] Jump function for loops

	Type	Function		Type	Function
I1	b	Finish loop	O1	-	-
I2	b	Restart loop	O2	-	-
I3	b	Update input buffer	P1	i	Jump target (index)
I4	b	Update output buffer	P2	i	number of repetitions

Description:

An instruction indicated as jump target in P1 is executed as often as indicated in P2. Via the inputs, the loop can be stopped or restarted.

- With P1, the jump target (the instruction to be executed repeatedly) is defined.
- With P2, the number of repetitions is defined.

The jump function can be at the end of a series of instructions to be processed repeatedly.

An internal counter is set to the value of P2 and counted down each time the instructions specified in P1 are called.

- If input I1 is TRUE, the loop is stopped before it is finished. The jump is not executed and the internal counter is reset to the start value P2.
- If input I2 is TRUE, the loop is restarted. The jump is executed and the internal counter is reset to the start value P2.
- If input I3 is TRUE, the input buffer is updated.
- If input I4 is TRUE, the output buffer is updated.

I1	I2	I3	I4	Function
1	0	0	0	Stop, reset to start value P2
0	1	0	0	Restart, reset to start value P2
0	0	1	0	Update input buffer
0	0	0	1	Update output buffer

I2 (restart) has priority over I1 (stop).

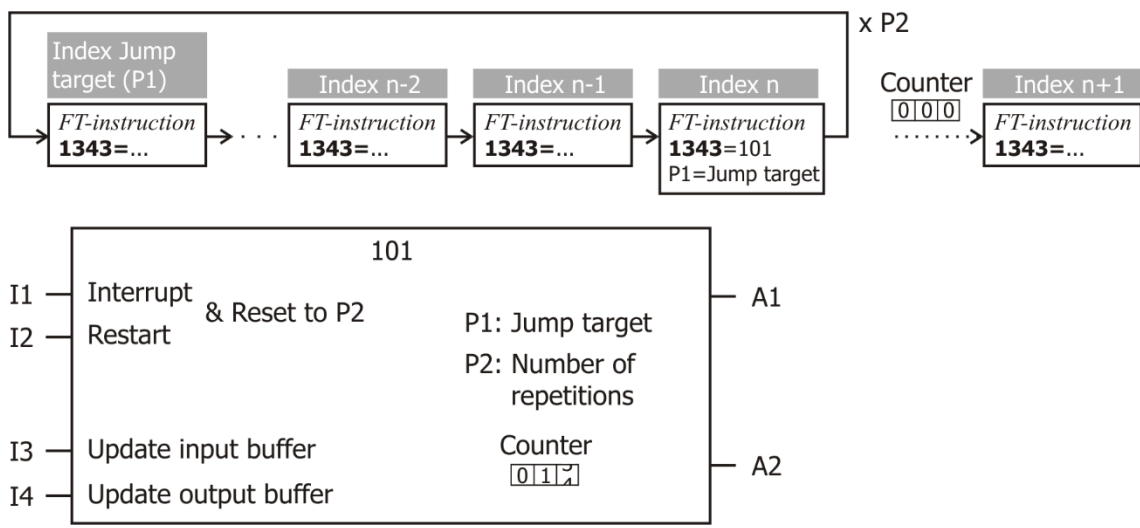

6 Description of analog functions

In the following, you will find explanations and examples of the individual analog functions. The term "analog function" is defined as follows:

An analog function has at least one analog input or output value. Other inputs are used as digital signals, depending on the function.

If the function has an analog output value (O1), the second output value (O2) is the inverted (negative) value.

If the function has both analog and Boolean inputs, the analog inputs are assigned the smaller ordinal numbers (I1 = analog, I4 = Boolean)

In the examples, the standard links of the input buffer are used. You can also parameterize other settings for the individual instructions.



In the case of some functions, output O2 is not used as an inverted output, but written with function-specific values. These functions are marked with "Long" for long variable.

In the descriptions, the following abbreviations are used:

- b Boolean (TRUE / FALSE) = 1 Bit
- % Percentage with/or without sign (int/unit) = 2 Byte = 16 Bit
- L Long Variable of type long = 4 byte = 32 bits
- i Any number
- 0 "Low" state. Representation of signal statuses in logic tables.
- 1 "High" state. Representation of signal statuses in logic tables.
- Off "Low" state. Representation of signal statuses in function descriptions.
- On "High" state. Representation of signal statuses in function descriptions.

6.1 Behavior

The behavior of the instructions can be set up via P1 and P2. The function of these parameters depends on the selected instruction.

Description	Min.	Max.
P1	0	65535
P2	0	65535

6.2 Comparators

6.2.1 [301, 302] Comparator (comparison of two variables)

	Type	Function		Type	Function
I1	%	Comparative value 1	O1	b	Output I1 > I2
I2	%	Comparative value 2	O2	b	O1 inverted
I3	b	Master-Set	P1	%	positive hysteresis (xxx.xx%)
I4	b	Master Reset	P2	%	negat. hysteresis (xxx.xx%)

Comparison of two variables

Description:

This function compares inputs I1 and I2.

O1 is TRUE if $I1 > I2$.

O1 is FALSE if $I1 < I2$.

If a hysteresis (P1 and P2) is set up:

O1 is TRUE if $I1 > (I2 + P1)$.

O1 is FALSE if $I1 < (I2 - P2)$.

The comparator has three working ranges:

Range 1	$(I2 + P1) < I1$	O1 = TRUE
Range 2	$(I2 - P2) < I1 < (I2 + P1)$	O1 remains unchanged.
Range 3	$I1 < (I2 - P2)$	O1 = FALSE

Description:

This function compares the absolute values of inputs I1 and I2.

O1 is TRUE if $|I1| > |I2|$.

O1 is FALSE if $|I1| < |I2|$.

If a hysteresis (P1 and P2) is set up:

O1 is TRUE if $|I1| > (|I2| + P1)$.

O1 is FALSE if $|I1| < (|I2| - P2)$.

The comparator has three working ranges:

Range 1	$(I2 + P1) < I1 $	O1 = TRUE
Range 2	$(I2 - P2) < I1 < (I2 + P1)$	O1 remains unchanged.
Range 3	$ I1 < (I2 - P2)$	O1 = FALSE

The output value can be changed by means of the two Boolean inputs I3 and I4:

Master Set sets output O1 to TRUE.

Master Reset sets output O1 to FALSE. Master Reset has priority over Master Set.

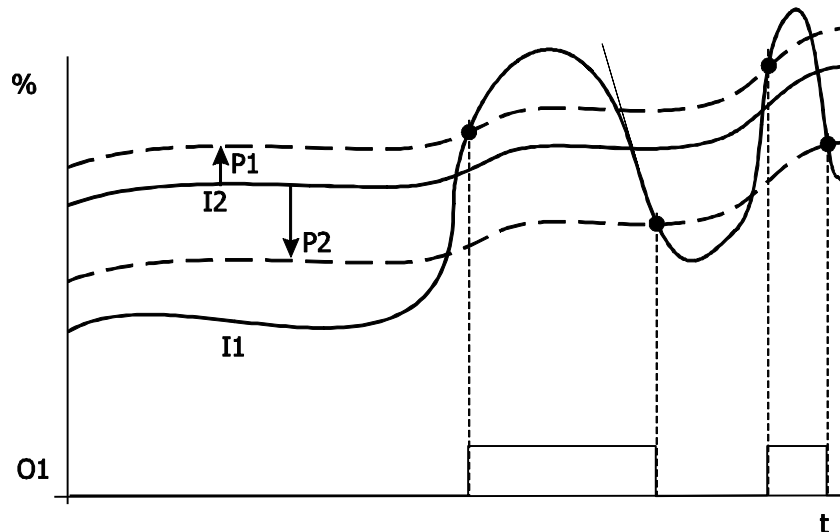
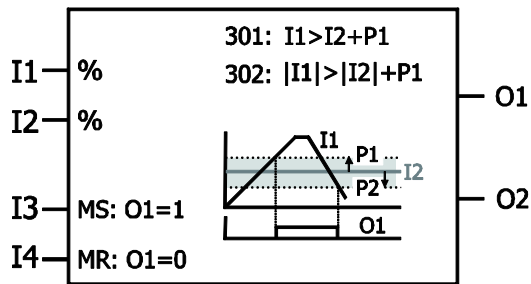

This function compares inputs I1 and I2. Percentages [%] have two decimals.
For example: Value 12345_{IN} = 123.45% = 1.2345

6.2.2 [303, 304] Comparator (comparison of constant to variable)

	Type	Function		Type	Function
I1	%	Comparative value 1	O1	b	Output I1 > P1
I2	-	-	O2	b	O1 inverted
I3	b	Master-Set	P1	%	upper threshold (xxx.xx%)
I4	b	Master Reset	P2	%	lower threshold (xxx.xx%)

"303 - Comp." (input with constant)

"304 - Comp." (input with constant), abs. value

303 - Comp.

Description:

This function compares input I1 to the switching thresholds P1 and P2.

O1 is TRUE if $I1 > P1$ (upper threshold).

O1 is FALSE if $I1 < P2$ (lower threshold).

O1 remains unchanged if I1 is in the range between P2 and P1.

The comparator has three working ranges:

Range 1	$P1 < I1$	O1 = TRUE
Range 2	$P2 < I1 < P1$	O1 remains unchanged.
Range 3	$I1 < P2$	O1 = FALSE

Special case:

P2 (lower threshold) is set higher than P1 (upper threshold) (thresholds exchanged):

O1 is TRUE if $I1 > P1$.

O1 will be reset if P1 is exceeded again and P2 was not exceeded.

O1 is also reset if P2 is exceeded first and then exceeded again.

– **304 - Comp. (input with constant), abs. value**

Description:

This function compares the absolute value of input I1 to the switching thresholds P1 and P2.

O1 is TRUE is $|I1| > P1$ (upper threshold).

O1 is FALSE if $|I1| < P2$ (lower threshold).

O1 remains unchanged if $|I1|$ is in the range between P2 and P1.

The comparator has three working ranges:

Range 1	$P1 < I1 $	O1 = TRUE
Range 2	$P2 < I1 < P1$	O1 remains unchanged.
Range 3	$ I1 < P2$	O1 = FALSE

Special case:

P2 (lower threshold) is set higher than P1 (upper threshold) (thresholds exchanged):

O1 is TRUE if $|I1| > P1$.

O1 will be reset if P1 is decreased again and P2 was not exceeded.

O1 is also reset if P2 is exceeded first and then decreased again.

The output value can be changed by means of the two Boolean inputs I3 and I4:

Master Set sets output O1 to TRUE.

Master Reset sets output O1 to FALSE. Master Reset has priority over Master Set.

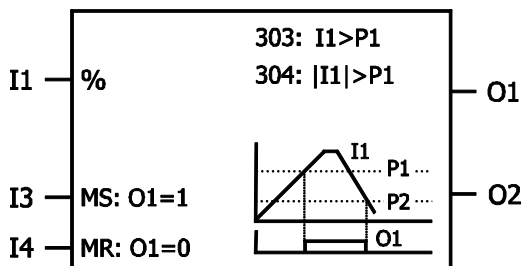

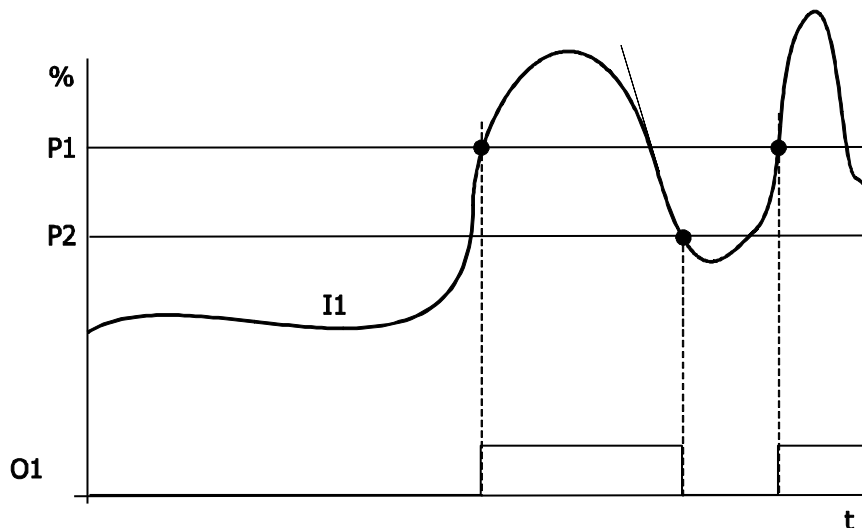

Percentages [%] have two decimals.

For example: Value $12345_{IN} = 123.45\% = 1.2345$

6.2.3 [308] Comparator for motion blocks

	Type	Function		Type	Function
I1	-	-	O1	b	P1 < current motion block < P2
I2	-	-	O2	b	O1 inverted
I3	b	Master-Set	P1	i	Motion block from
I4	b	Master Reset	P2	i	Motion block to

Description:

This function compares the two parameters P1 and P2 to the current motion block of the table positioning. If the current motion block is within the two defined parameters, the output is set to TRUE.

The output of the comparator is TRUE if a motion block is active in the table positioning in the range P1 ... P2.

The output value can be changed by means of the two Boolean inputs I3 and I4:

Master Set sets output O1 to TRUE.

Master Reset sets output O1 to FALSE. Master Reset has priority over Master Set.

Examples:



■ : O1 = TRUE

Special case: P1 > P2:

O1 = TRUE if a motion block from ranges 1 to P2 or P1 to 32 is active.

6.2.4 [309] Position comparator (long)

	Type	Function		Type	Function
I1	L	Comparative	O1	b	Output I1 > I2
I2	L	Comparative	O2	b	O1 inverted
I3	b	Master-Set	P1	%	positive hysteresis (low word)
I4	b	Master Reset	P2	%	negative hysteresis (low word)

Description:

This function compares inputs I1 and I2. This function is intended for long variables (positions, ramps of table positioning).

O1 is TRUE if $I1 > I2$.

O1 is FALSE if $I1 < I2$.

If a hysteresis (P1 and P2) is set up:

O1 is TRUE if $I1 > (I2 + P1)$.

O1 is FALSE if $I1 < (I2 - P2)$.

O1 remains unchanged if I1 is in the range of the hysteresis: $(I2 - P2) < I1 < (I2 + P1)$.

The comparator has three working ranges:

Range 1	$(I2 + P1) < I1$	O1 = TRUE
Range 2	$(I2 - P2) < I1 < (I2 + P1)$	O1 remains unchanged.
Range 3	$I1 < (I2 - P2)$	O1 = FALSE

The output value can be changed by means of the two Boolean inputs:

Master Set sets output O1 to TRUE.

Master Reset sets output O1 to FALSE. Master Reset has priority over Master Set.

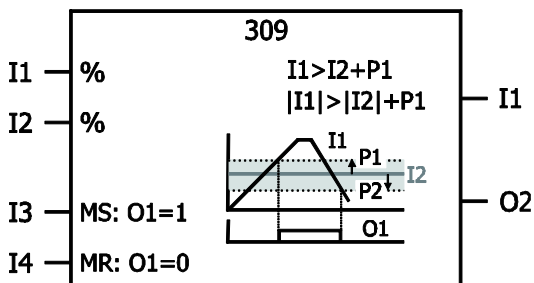

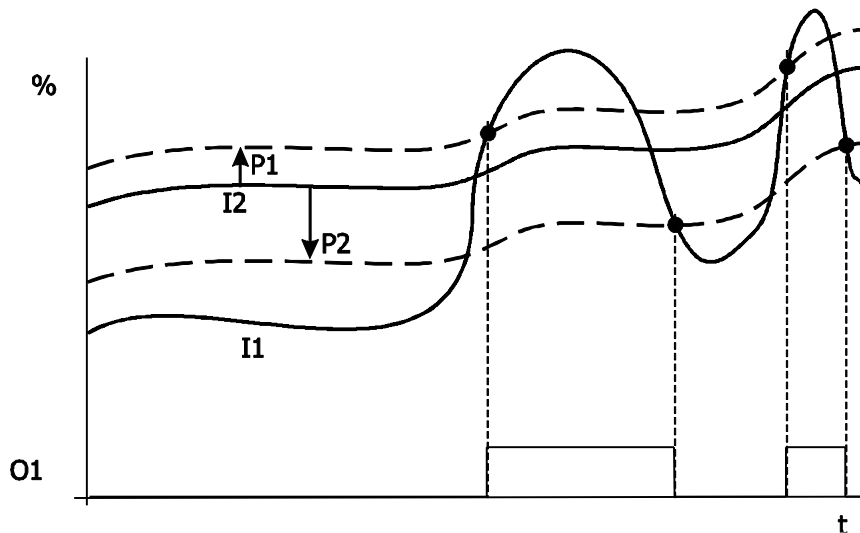

6.2.5 [310] Analog hysteresis

	Type	Function		Type	Function
I1	%	Input value	O1	b	Output
I2	%	Variable hysteresis	O2	b	O1 inverted
I3	b	Start	P1	%	Constant hysteresis
I4	b	Master Reset	P2	-	-

Description:

Signal (status-controlled) at I3 saves actual value at I1. The hysteresis values I2 (variable) and P1 (constant) are added to and subtracted from the saved value. If the value of I1 is within the hysteresis, the saved value is output. If the value of I1 is outside of the hysteresis, the current value of I1 is output.

If the start input I3 is set, the input value I1 is maintained ($F = I1$).

$$I1 > F + (I2 + P1) \rightarrow O1 = I1$$

$$I1 < F - (I2 + P1) \rightarrow O1 = I1$$

$$F - (I2 + P1) < I1 < F + (I2 + P1) \rightarrow O1 = F$$

Master Reset sets output O1 to FALSE.

If Master Reset is reset, the process must be started again via I3.

Output A = f(input E)

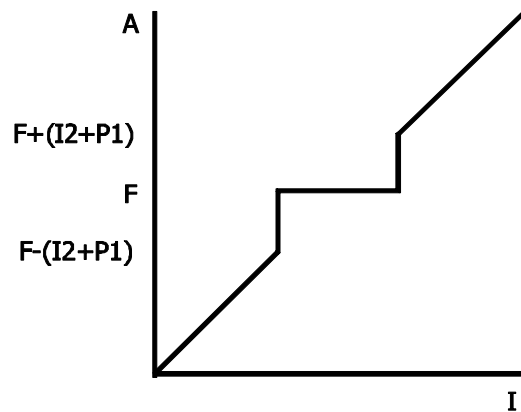

Output A = f(t)

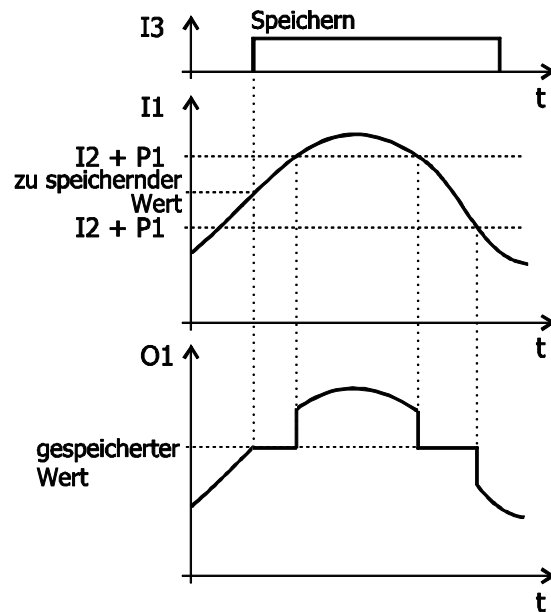

I3	I4	Function
1	0	Keep I1 at O1 constant.
x	1	Set O1 to FALSE.



Percentages [%] have two decimals.

For example: Value $12345_{IN} = 123.45\% = 1.2345$

6.2.6 [311, 312] Window comparator (comparison of two variables)

	Type	Function		Type	Function
I1	%	Comparative value	O1	b	Output I1 > I2
I2	%	Comparative value	O2	b	O1 inverted
I3	b	Master-Set	P1	%	positive window (xxx.xx%)
I4	b	Master Reset	P2	%	negative window (xxx.xx%)

"311 – W. Comp (2 V)" (Window comparator, two variables)

"312 – W. Comp (2 V)" absolute value" (Window comparator, two variables, absolute value)

311 – W. comp (2 V)

Description:

It is checked if I1 is in the adjusted range (window) around I2.

O1 is TRUE if I1 is in the range of I2. The range is set up with P1 (positive window) and P2 (negative window).

O1 is FALSE if I1 is outside of this range.

The comparator has three working ranges:

Range 1	$(I2 + P1) < I1$	O1 = FALSE
Range 2	$(I2 - P2) < I1 < (I2 + P1)$	O1 = TRUE
Range 3	$I1 < (I2 - P2)$	O1 = FALSE

312 – W. comp (2 V), absolute value

Description:

It is checked if the absolute value I1 is in the adjusted range (window) around absolute value of I2.

O1 is TRUE if $|I1|$ is in the range of $|I2|$. The range is set up with P1 (positive window) and P2 (negative window).

O1 is FALSE if $|I1|$ is outside of this range.

The comparator has three working ranges:

Range 1	$(I2 + P1) < I1 $	O1 = FALSE
Range 2	$(I2 - P2) < I1 < (I2 + P1)$	O1 = TRUE
Range 3	$ I1 < (I2 - P2)$	O1 = FALSE

The output value can be changed by means of the two Boolean inputs I3 and I4:

Master Set sets output O1 to TRUE.

Master Reset sets output O1 to FALSE. Master Reset has priority over Master Set.

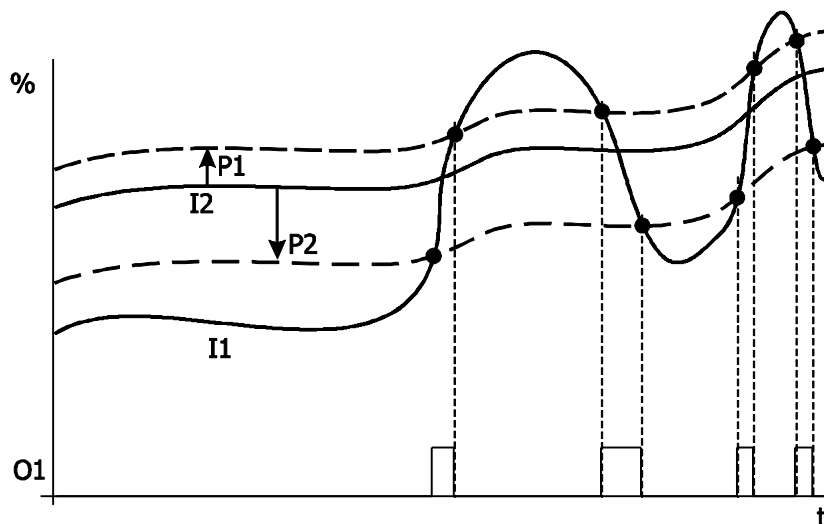
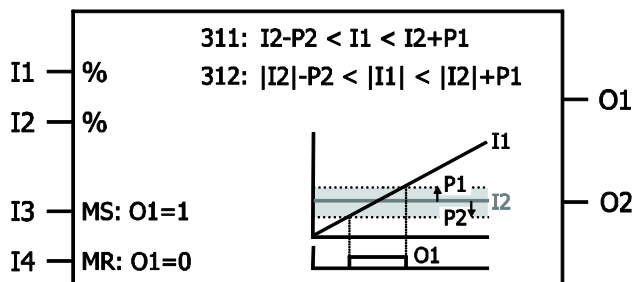

Percentages [%] have two decimals.

For example: Value 12345_{IN} = 123.45% = 1.2345

6.2.7 [313, 314] Window comparator (comparison of constant to variable)

	Type	Function		Type	Function
I1	%	Comparative value 1	O1	b	Output I1 > I2
I2	-	-	O2	b	O1 inverted
I3	b	Master-Set	P1	%	positive window (xxx.xx%)
I4	b	Master Reset	P2	%	negative window

"313 - Window comparator (V C)", comparison of variable to constant

"314 - Window comparator (V C)", absolute value", comparison of variable to constant

– 313 - Window comparator (V C)

Description:

Via P1 and P2, a value range (window) is adjusted and it is checked if I1 is within this constant range.

O1 is TRUE if I1 is in the range of from P2 to P1.

O1 is FALSE if I1 is outside of this range.

The comparator has three working ranges:

Range 1	$P1 < I1$	O1 = FALSE
Range 2	$P2 < I1 < P1$	O1 = TRUE
Range 3	$I1 < P2$	O1 = FALSE

Special case:

P2 (negative window) is greater than P1 (positive window) (limits exchanged):

O1 is TRUE if $I1 < P1$ or $I1 > P2$.

O1 is FALSE if I1 is in the range of from P1 to P2 (window).

– 314 - Window comparator (V C), absolute value", comparison of variable to constant

Description:

Via P1 and P2, a value range (window) is adjusted and it is checked if the absolute value of I1 is within this range.

O1 is TRUE if $|I1|$ is in the range of P2 to P1.

O1 is FALSE if $|I1|$ is outside of this range.

The comparator has three working ranges:

Range 1	$P1 < I1 $	O1 = FALSE
Range 2	$P2 < I1 < P1$	O1 = TRUE
Range 3	$ I1 < P2$	O1 = FALSE

Special case:

P2 (negative window) is greater than P1 (positive window) (limits exchanged):

O1 is TRUE if $|I1| < P1$ or $|I1| > P2$.

O1 is FALSE if $|I1|$ is in the range of P1 to P2 (window).

The output value can be changed by means of the two Boolean inputs:

Master Set sets output O1 to TRUE.

Master Reset sets output O1 to FALSE. Master Reset has priority over Master Set.

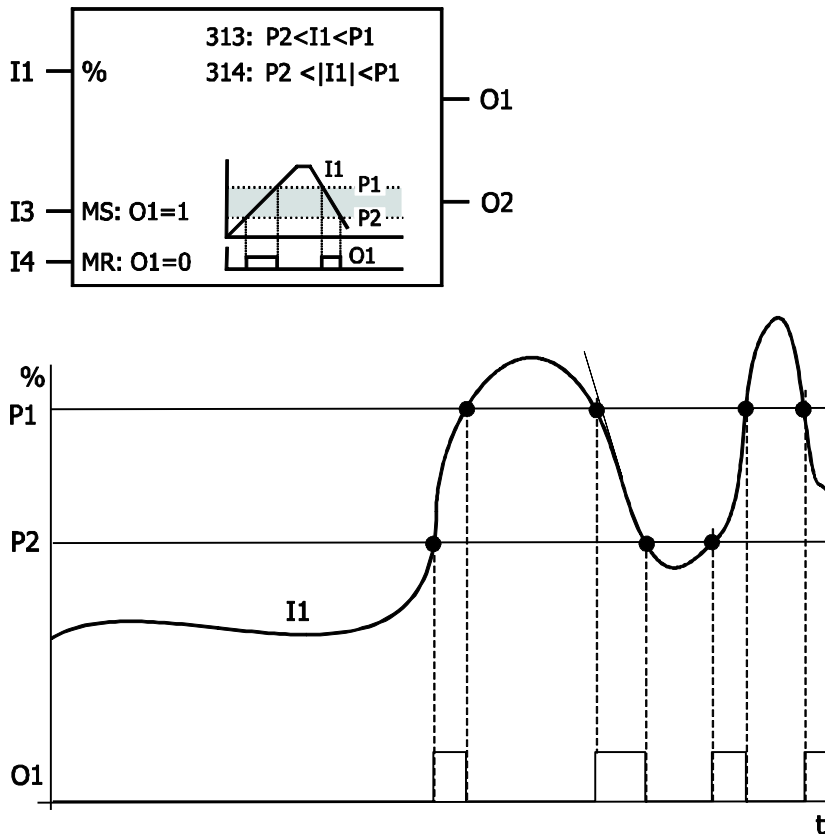

Percentages [%] have two decimals.

For example: Value $12345_{IN} = 123.45\% = 1.2345$

6.2.8 [320] Min/Max

	Type	Function
I1	%	input value 1
I2	%	input value 2
I3	b	FALSE=Min/TRUE=Max
I4	b	Master Reset

	Type	Function
O1	%	Min or Max (I1;I2;P1;P2)
O2	%	O1 inverted
P1	%	Constant value P1
P2	%	Constant value P2

Description:

Based on variables I1 and I2 as well as the constants P1 and P2, the minimum or maximum value is determined and output at O1.

The **maximum** value is output if I3 is TRUE.

The **minimum** value is output if I3 is FALSE.

I3 = FALSE: O1 = -O2 = Minimum (I1, I2, P1, P2)

I3 = TRUE: O1 = -O2 = Maximum (I1, I2, P1, P2)

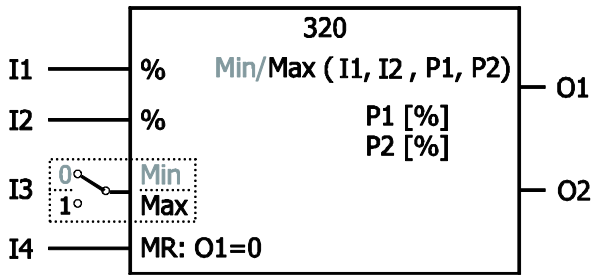

Note:

P1 and P2 are not evaluated when the maximum or minimum value is determined if they are set to 0.

I2 is not evaluated when the maximum or minimum value is determined if I2 is connected to signal source "9 - Zero".

As long as status TRUE is present at I4 (Master Reset), the output value is FALSE.



Percentages [%] have two decimals.
For example: Value $12345_{IN} = 123.45\% = 1.2345$

6.2.9 [321] Min / Max for position values (Long)

	Type	Function		Type	Function
I1	Pos	input value 1	O1	Pos	Min or Max
I2	Pos	input value 2	O2	Pos	(I1;I2;P)
I3	b	FALSE=Min/TRUE=Max	P1	Pos	Constant value
I4	b	Master Reset	P2	Pos	Constant value
					Low word
					High word
					Low word
					High word

Description:

Based on variables I1 and I2 as well as constant P, the minimum or maximum value is determined and output.

The **maximum** value is output if I3 is TRUE.

The **minimum** value is output if I3 is FALSE.

I3 = FALSE: O = Minimum (I1, I2, P)

I3 = TRUE: O = Maximum (I1, I2, P)

with O1, P1: Low word
O2, P2 High word



P1 and P2 are not evaluated when the maximum or minimum value is determined if they are set to 0.

I2 is not evaluated when the maximum or minimum value is determined if I2 is connected to signal source "9 - Zero".



Output value O2 is **not** the inverted value of O1.
The output can be combined with inputs for position values (Long).
The function can also be used for ramp settings in configurations x40.

6.2.10 [322] Min/Max in time window

	Type	Function		Type	Function
I1	%	input value 1	O1	%	Min or Max
I2	-	-	O2	%	O1 inverted
I3	b	FALSE=Min/TRUE=Max	P1	-	-
I4	b	Master Reset	P2	-	-

Description:

The minimum input value at I1 determined over a certain period of time, is output to Output O1 if I3 is TRUE and I4 is FALSE.

Or:

The maximum input value at I1 determined over a certain period of time, is output to Output O1 if I3 is FALSE and I4 is FALSE.

Or:

The current input value at I1 is output to O1, if I4 is TRUE.

The signal status at I3 determines if the minimum or maximum input value is output. FALSE must be present at I4.

The period of time for the minimum or maximum value measurement is determined by a signal at I4. The measurement of the maximum or minimum value starts with a negative edge at I4. The measurement is restarted with each negative edge.

I3	I4	O1=
0	0	Minimum (I1)
1	0	Maximum (I1)
x	1	O1



Percentages [%] have two decimals.

For example: Value $12345_{IN} = 123.45\% = 1.2345$

6.2.11 [323] Min/Max for positions (Long) in time window

	Type	Function		Type	Function
I1	Pos	input value 1	O1	Pos	Min or Max (I1) Low word
I2	-	-	O2	Pos	
I3	b	FALSE=Min/TRUE=Max	P1	-	-
I4	b	Master Reset	P2	-	-

Description:

The **minimum** position value at I1 determined over a certain period of time, is output if I3 is TRUE and I4 is FALSE.

Or:

The **maximum** position value at I1 determined over a certain period of time, is output if I3 is FALSE and I4 is FALSE.

Or:

The current position value at I1 is output, if I4 is TRUE.

The signal status at I3 determines if the minimum or maximum position value is output. FALSE must be present at I4.

The period of time for the minimum or maximum value measurement is determined by a signal at I4. The measurement of the maximum or minimum value starts with a negative edge at I4. The measurement is restarted with each negative edge at I4.

I3	I4	O=
0	0	Minimum (I1)
1	0	Maximum (I1)
x	1	I1

Note:

Output value I2 is **not** the inverted value of O1.

The output can be combined with inputs for position values (Long).

The function can also be used for ramp settings in configurations x40. The availability of configurations x40 depends on the device series.

6.3 Mathematical functions

	Description	Formula	Limits
330	Addition and subtraction of input values and an offset.	$O1 = -O2 = I1 + I2 - I3 + P1 - P2$	$\pm 327.67\%$
331	Addition and subtraction of position values and offset. Result Long.	$O = I1 + I2 - I3 + P$ O1, P1 = Low word O2, P2 = High word	0 ... $(2^{32}-1)$
332	Multiplication of the input values and a factor.	$O1 = -O2 = I1 \times I2 \times P1$	$\pm 327.67\%$
333	Multiplication of position values and offset. Result Long.	$O2 \mid O1 = I1 \times I2 \times P1$ O1 = Low word O2 = High word	0 ... $(2^{32}-1)$
334	Multiplication of input value by a constant fraction.	$O1 = -O2 = I1 \times \frac{P1}{P2}$	$\pm 327.67\%$
335	Multiplication of long input value by percentage divided by a constant.	$O1 = -O2 = \frac{I1 \times I2}{P1}$	0 ... $(2^{32}-1)$
336	Division of an input value by variable input values.	$O1 = -O2 = \frac{I1}{I2 \times I3}$	+P1 - P2 [$\pm 327.67\%$]
337	Division of input value by constant.	$O1 = -O2 = \frac{I1}{P1}$	$\pm P2$ [$\pm 327.67\%$]
338	Division of a constant by the input value (reciprocal).	$O1 = -O2 = \frac{P1}{I1}$	$\pm P2$ [$\pm 327.67\%$]
339	Combined multiplication and division.	$O1 = -O2 = \frac{I1 \times I2}{I3}$	+P1 - P2 [$\pm 327.67\%$]
340	Average from 3 input values. Multiplication by constant fraction as correction factor.	$O1 = -O2 = \frac{I1 + I2 + I3}{3} \times \frac{P1}{P2}$	$\pm 327.67\%$
341	Absolute value of two orthogonal components. Multiplication by constant fraction.	$O1 = -O2 = \sqrt{I1^2 + I2^2} \times \frac{P1}{P2}$	$\pm 327.67\%$
342	Absolute value of three orthogonal components. Multiplication by constant fraction.	$O1 = -O2 = \sqrt{I1^2 + I2^2 + I3^2} \times \frac{P1}{P2}$	$\pm 327.67\%$
350	Integrator	$O1 = -O2 = \frac{1}{P1} \int I1 dt + I2$	$\pm 327.67\%$
351	Differentiator (D-element)	$O1 = -O2 = \frac{1}{P1} \times \frac{dI1}{dt}$	$\pm 327.67\%$
360	Absolute value function	$O1 = -O2 = I1 $	$\pm 327.67\%$
361	Input value squared.	$O1 = -O2 = I1^2$	+ P2 [$\pm 327.67\%$]

	Description	Formula	Limits
362	Input value cubed.	$O1 = -O2 = I1^3$	$\pm P2$ [$\pm 327.67\%$]
363	Square root of input value.	$O1 = -O2 = \sqrt{ I1 } \times \frac{ I1 }{I1}$; $+ I1 \Rightarrow O1 = +\sqrt{ I1 }$ $- I1 \Rightarrow O1 = -\sqrt{ I1 }$	$\pm P2$ [$\pm 327.67\%$]
364	Modulo, multiplication and division, result with remainder	$O1, O2 = \frac{I1 \times I2 \times P1}{I3 \times P2}$; $O1 = \text{Ergebnis}$ $O2 = \text{Rest}$	$\pm 327.67\%$

6.3.1 Addition and subtraction

6.3.1.1 [330] Add. $O1 = -O2 = I1 + I2 - I3 + P1 - P2$

	Type	Function		Type	Function
I1	%	positive input I1	O1	%	$O1 = I1 + I2 - I3 + P1 - P2$
I2	%	positive input I2	O2	%	inverted output = -O1
I3	%	negative input I3	P1	%	positive offset
I4	b	Master Reset	P2	%	negative offset

Description:

This function adds inputs I1 and I2 and subtracts input I3. In addition, a positive and negative offset can be defined via P1 and P2, respectively.

$$O1 = -O2 = I1 + I2 - I3 + P1 - P2$$

The result of the addition is limited to $\pm 327.67\%$. Interim results are not limited.

As long as status TRUE is present at I4 (Master Reset), the output value at O1 is 0.

Example:

$$\begin{aligned}
 \mathbf{I1} &= 3240 (=32.40\%) & \mathbf{O1} &= 32.40\% + 56,13\% - 270.28\% + 3.90\% - 3.22\% \\
 \mathbf{I2} &= 5613 (=56.13\%) & &= -181,07\% \\
 \mathbf{I3} &= 27028 (=270.28\%) \\
 \mathbf{P1} &= 390 (=3.90\%) \\
 \mathbf{P2} &= 322 (=3.22\%)
 \end{aligned}$$

Input for parameters, e.g.:

32.40%

P2 = 390



Percentages [%] have two decimals.

For example: Value $12345_{IN} = 123.45\% = 1.2345$

6.3.1.2 [331] Addition position with offset

	Type	Function		Type	Function
I1	Pos	positive input I1	O1	Pos	$O = I1 + I2 - I3 + P$
I2	Pos	positive input I2	O2	Pos	
I3	Pos	negative input I3	P1	Pos	Positions offset P
I4	b	Master Reset	P2	Pos	

Description:

This function adds inputs I1 and I2 and subtracts input I3. In addition, an offset can be specified.

$$O2 | O1 = I1 + I2 - I3 + P2 | P1;$$

$$O2 | O1 = \text{High - word} | \text{Low - word};$$

$$P2 | P1 = \text{High - word} | \text{Low - word}$$

The output value comprises a High word (O1) and a Low word (O2). The positions offset which is added is also separated in High word and Low word.

As long as status TRUE is present at I4 (Master Reset), the output value is 0.

Note:

Output value O2 is **not** the inverted value of O1.

The output can be combined with inputs for position values (Long).

The function can also be used for ramp settings in configurations x40.

The availability of configuration x40 depends on the device series.

Example:

$$I1 = 35468240$$

$$I2 = 5613$$

$$I3 = 27028$$

$$P = 270000 = 41EB0_{\text{hex}}$$

$$P1 = 1EB0_{\text{hex}} = 7856$$

$$P2 = 0004_{\text{hex}} = 4$$

$$O = 35468240 + 5613 + 27028 + 270000$$

$$= 35770881$$

$$= 221D201_{\text{hex}}$$

$$O1 = D201_{\text{hex}} [= 53761]$$

$$O2 = 0221_{\text{hex}} [= 545]$$

6.3.2 Multiplication

6.3.2.1 [332] Multiplication

	Type	Function		Type	Function
I1	%	input value 1	O1	%	$O1 = I1 \times I2 \times P1$
I2	%	input value 2	O2	%	inverted output = -O1
I3	-	-	P1	%	Factor (numerator)
I4	b	Master Reset	P2	-	-

Description:

This function multiplies inputs I1 by I2 and by factor P1.

$$O1 = -O2 = I1 \times I2 \times P1$$

The result of the multiplication is limited to $\pm 327.67\%$.

As long as status TRUE is present at I4 (Master Reset), the output value O1 is 0.

Note:

100.00% * 100.00% = 100.00%

Example:

I1=3240 (=32.40%) O1 = 32.40% * 3.58% * 270.00%
I2=358 (=3.58%) = 0.324 * 0.0358 * 2.70
P1=270 (=270.00%) = 0.0313 = 3.13%



Percentages [%] have two decimals.
 For example: Value 12345_{IN} = 123.45% = 1.2345

6.3.2.2 [333] Multiplication, Long result

	Type	Function		Type	Function
I1	%	positive input I1	O1	%	O = I1 × I2 × P1
I2	%	positive input I2	O2	%	
I3	-	-	P1	%	Factor
I4	b	Master Reset	P2	-	-

Description:

Inputs I1 and I2 as well as Factor P1 are multiplied by one another.
 The result at the output is divided in a High word (O1) and a Low word (O2).
 O2 | O1 = I1 × I2 × P1; O2 | O1 = High – word | Low – word

The result of the multiplication (long) is not limited.

As long as status TRUE is present at I4 (Master Reset), the output value is 0.

If P1 is set to value 0, O = I1 x I2 is calculated.



The output value at O2 is not the inverted value of O1.

The output can be combined with inputs for position values (Long).
 The function can also be used for ramp settings in configurations x40.

Example:

I1=24000 (=240.00%) O = 240.00% * 310.00% * 630.00%
I2=31000 (=310.00%) = (2.4000 * 3.1000 * 6,3000)
P1=63000 (=630.00%) = 4687.20%
 = 726F0_{hex}
 O1= 26F0_{hex} [= 9968]
 O2= 0007_{hex} [= 7]



Percentages [%] have two decimals.
 For example: Value 12345_{IN} = 123.45% = 1.2345

6.3.2.3 [334] Mult. by fraction

	Type	Function		Type	Function
I1	%	input value 1	O1	%	$O1 = I1 \times \frac{P1}{P2}$
I2	-	-	O2	%	inverted output = -O1
I3	-	-	P1	%	Factor numerator
I4	b	Master Reset	P2	%	Factor denominator

Description:

The input value at I1 is multiplied by the parameter value P1 and divided by parameter value P2.

$$O1 = -O2 = I1 \times \frac{P1}{P2}$$

The result of the multiplication is limited to $\pm 327.67\%$.

As long as status TRUE is present at I4 (Master Reset), the output value O1 is 0.

Example:

$$\begin{aligned}
 I1 &= 14000 \quad (=140.00\%) & O1 &= 140.00\% * 150.00\% / 32.33\% \\
 P1 &= 15000 \quad (=150.00\%) & &= (1.4000 * 1.5000 / 0.3233 = 6,4955) \\
 P2 &= 3233 \quad (=32.33\%) & &= 649.55\%, \text{ limited to } 327.67\%
 \end{aligned}$$



Percentages [%] have two decimals.

For example: Value $12345_{IN} = 123.45\% = 1.2345$

If P2 is set to value 0, the output has the value 327.67%. The sign is applied from the input value.

6.3.2.4 [335] Mult. long * percent

	Type	Function		Type	Function
I1	Long	input value 1	O1	Pos	$O = I1 \times \frac{I2}{P1}$
I2	%	input value 2		O2	
I3	-	-	P1	%	Denominator
I4	b	Master Reset	P2	-	-

Description:

The input value at I1 (long) is multiplied by the parameter value I2 (percentage) and divided by parameter value P1.

$$O = I1 \times \frac{I2}{P1}$$

The output value comprises a High word (O1) and a Low word (O2).

O2 | O1 = High - word | Low - word

The result of the multiplication (long) is not limited.

As long as status TRUE is present at I4 (Master Reset), the output value is 0.

The output value at O2 is **not** the inverted value of O1.

The output can be combined with inputs for position values (Long).



Percentages [%] have two decimals.
For example: Value 12345_{IN} = 123.45% = 1.2345

6.3.3 Division

6.3.3.1 [336] Division

	Type	Function		Type	Function
I1	%	Input (numerator)	O1	%	$O1 = \frac{I1}{I2 \times I3}$
I2	%	Input (denominator 1)	O2	%	inverted output = -O1
I3	%	Input (denominator 2)	P1	%	upper limit
I4	b	Master Reset	P2	%	lower limit

Description:

The input value at I1 is divided by the product from input values I2 and I3.

$$O1 = -O2 = \frac{I1}{I2 \times I3}$$

The result of the division is limited to -P2 and +P1 (max. to ±327.67%).

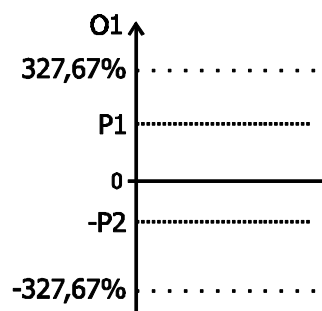

P2 is the negative limit (-P2), even if only a positive value can be entered for P2.

As long as status TRUE is present at I4 (Master Reset), the output value O1 is 0.

Signal source "9 - Zero" or the value 0 at input I2 or I3 deactivates these inputs. In this case, no division by the input values at I2 and I3 is carried out. The input values are processed as I2=1 and I3=1.

Example:

$$\begin{aligned}
 I1 &= 14000 \quad (=140.00\%) & O1 &= 140.00\% / 130.00\% / 32.33\% \\
 I2 &= 3000 \quad (=30.00\%) & &= (1.4000 / 0.3000 / 0.3233) \\
 I3 &= 3233 \quad (=32.33\%) & &= |14434.47\%| \text{ limit} \\
 & & &= 327.67\%
 \end{aligned}$$



Percentages [%] have two decimals.
For example: Value 12345_{IN} = 123.45% = 1.2345
If EI2 or I3 has value 0, output O1 has value I1.

6.3.3.2 [337] Division by constant

	Type	Function		Type	Function
I1	%	Input (numerator)	O1	%	$O1 = \frac{I1}{P1}$
I2	-	-	O2	%	inverted output = -O1
I3	-	-	P1	%	Constant (denominator)
I4	B	Master Reset	P2	%	upper and lower limit

Description:

The input value at I1 is divided by the parameter value P1.

$$O1 = -O2 = \frac{I1}{P1}$$

The result of the division is limited to $\pm P2$ (max. to $\pm 327.67\%$).

As long as status TRUE is present at I4 (Master Reset), the output value O1 is 0.

Example:

$$\begin{aligned}
 I1=14000 \text{ (=140.00\%)} & & O1 &= 140.00\% / 40.00\% \\
 P1=4000 \text{ (=40.00\%)} & & &= (1.4000 / 0.4000) \\
 & & &= |350.00\%| \text{ limit} \\
 & & &= 327.67\%
 \end{aligned}$$



Percentages [%] have two decimals.

For example: Value $12345_{IN} = 123.45\% = 1.2345$

If P1 is set to value 0, the output has the value 327.67%. The sign is applied from the input value.

6.3.3.3 [338] Division P1 by I1, reciprocal

	Type	Function		Type	Function
I1	%	Input (denominator)	O1	%	$O1 = \frac{P1}{I1}$
I2	-	-	O2	%	inverted output = -O1
I3	-	-	P1	%	Constant (numerator)
I4	b	Master Reset	P2	%	upper and lower limit

Description:

The parameter value P1 is divided by the input value at I1 (reciprocal).

$$O1 = -O2 = \frac{P1}{I1}$$

The result of the division is limited to $\pm P2$ (max. to $\pm 327.67\%$).

As long as status TRUE is present at I4 (Master Reset), the output value O1 is 0.

Example:

$$\begin{aligned}
 I1=14000 \text{ (=140.00\%)} & & O1 &= 40.00\% / 140.00\% \\
 P1=4000 \text{ (=40.00\%)} & & &= (0.4000 / 1.4000) \\
 & & &= 28.57\%
 \end{aligned}$$



Percentages [%] have two decimals.

For example: Value $12345_{IN} = 123.45\% = 1.2345$

If I1 has value 0, output O1 has value 327.67% or the value of P2.

6.3.4 [339] Multiplication and division

	Type	Function		Type	Function
I1	%	Input (numerator 1)	O1	%	$O1 = \frac{I1 \times I2}{I3}$
I2	%	Input (numerator 2)	O2	%	inverted output = -O1
I3	%	Input (denominator)	P1	%	upper limit
I4	b	Master Reset	P2	%	lower limit

Description:

The input value at I1 is multiplied by the input value at I2 and the result is divided by the input value at I3.

$$O1 = -O2 = \frac{I1 \times I2}{I3}$$

The result of the division is limited to -P2 ... +P1 (max. to $\pm 327.67\%$).

As long as status TRUE is present at I4 (Master Reset), the output value O1 is 0.

Example:

$$\begin{aligned} I1 &= 14000 (=140.00\%) & O1 &= 140.00\% * 40.00\% / 20.00\% \\ I2 &= 4000 (=40.00\%) & &= (1.4000 * 0.4000 / 0.2000) \\ I3 &= 2000 (=20.00\%) & &= 280.00\% \end{aligned}$$



Percentages [%] have two decimals.

For example: Value $12345_{IN} = 123.45\% = 1.2345$

6.3.5 [340] Average function

	Type	Function		Type	Function
I1	%	Input 1	O1	%	$O1 = \frac{I1 + I2 + I3}{3} \times \frac{P1}{P2}$
I2	%	Input 2	O2	%	inverted output = -O1
I3	%	Input 3	P1	i	Factor numerator
I4	b	Master Reset	P2	i	Factor denominator

Description:

The average is calculated from the input values at I1, I2 and I3.

Parameters P1 and P2 can be adjusted as correction factors.

$$O1 = -O2 = \frac{I1 + I2 + I3}{3} \times \frac{P1}{P2}$$

As long as status TRUE is present at I4 (Master Reset), the output value O1 is 0.

Example:

$$\begin{aligned} I1 &= 14000 (=140.00\%) & O1 &= (140.00\% + 40.00\% + 20.00\%) / 3 * 5/4 \\ I2 &= 4000 (=40.00\%) & &= 200\% / 3 * 5/4 \\ I3 &= 2000 (=20.00\%) & &= 83.33\% \\ P1 &= 5 \\ P2 &= 4 \end{aligned}$$

If the average is to be calculated from two input values only, I1 and I2 must be used and I3 must be set to FALSE.

$$O1 = \frac{I1 + I2}{2} \times \frac{P1}{P2}$$



Percentages [%] have two decimals.

For example: Value 12345_{IN} = 123.45% = 1.2345

6.3.6 [341] Absolute value of two orthogonal components (2 D vector)

	Type	Function		Type	Function
I1	%	input value 1	O1	%	$O1 = \sqrt{I1^2 + I2^2} \times \frac{P1}{P2}$
I2	%	input value 2	O2	%	inverted output = -O1
I3	-	-	P1	%	Constant (numerator)
I4	b	Master Reset	P2	%	Constant (denominator)

Description:

The absolute value is formed from the orthogonal (square-angle) input values at I1 and I2.

The absolute value is multiplied by the constant $\frac{P1}{P2}$.

$$O1 = -O2 = \sqrt{I1^2 + I2^2} \times \frac{P1}{P2}$$

As long as status TRUE is present at I4 (Master Reset), the output value O1 is 0.

Example:

I1=14000 (=140.00%)

I2=4000 (=40.00%)

P1= 500 (= 5.00%)

P2= 10000 (= 100.00%)

$$\begin{aligned}
 O1 &= \sqrt{140,00\%^2 + 40,00\%^2} \times \frac{5,00\%}{100,00\%} \\
 &= \sqrt{212,00\%} \times \frac{5,00\%}{100,00\%} \\
 &= 7,28\%
 \end{aligned}$$



Percentages [%] have two decimals.

For example: Value 12345_{IN} = 123.45% = 1.2345

6.3.7 [342] Absolute value of three orthogonal components (3 D vector)

	Type	Function		Type	Function
I1	%	input value 1	O1	%	$O1 = \sqrt{I1^2 + I2^2 + I3^2} \times \frac{P1}{P2}$
I2	%	input value 2	O2	%	inverted output = -O1
I3	%	input value 3	P1	%	Constant (numerator)
I4	b	Master Reset	P2	%	Constant (denominator)

Description:

The absolute value is formed from the orthogonal (square-angle) input values at I1, I2 and I3.

The absolute value is multiplied by the constants $\frac{P1}{P2}$.

$$O1 = -O2 = \sqrt{I1^2 + I2^2 + I3^2} \times \frac{P1}{P2}$$

As long as status TRUE is present at I4 (Master Reset), the output value O1 is 0.

Example:

I1= 14000 (=140.00%)

I2= 4000 (=40.00%)

I3= 3000 (=30.00%)

P1= 500 (= 5.00%)

P2= 10000 (= 100.00%)

$$\begin{aligned} O1 &= \sqrt{140,00\%^2 + 40,00\%^2 + 30,00\%^2} \times \frac{5,00\%}{100,00\%} \\ &= \sqrt{221,00\%} \times \frac{5,00\%}{100,00\%} \\ &= 7,43\% \end{aligned}$$



Percentages [%] have two decimals.

For example: Value 12345_{IN} = 123.45% = 1.2345

6.3.8 [350] Integrator

	Type	Function
I1	%	Integration quantity
I2	%	Start value
I3	b	Master Set
I4	b	Master Reset

	Type	Function
O1	%	$O1 = \frac{1}{P1} \int I1dt + I2$
O2	%	inverted output = -O1
P1	i	Integration time in ms (denominator)
P2	-	-

Description:

The input value at I1 is integrated.

The integration time constant P1 indicates how long it takes in the case of a constant input value until the output value reaches the input value.

$$O1 = -O2 = \frac{1}{P1} \int I1dt + I2$$

If the integrator is to be stopped, input 2 must be combined with the output and the Master Set input (I3) must be activated.

Master Set: TRUE sets the integrator to the start value (I2). The start value can be defined via input I2.

Master-Reset: TRUE sets the integrator to 0.

Master Reset has priority over Master Set.

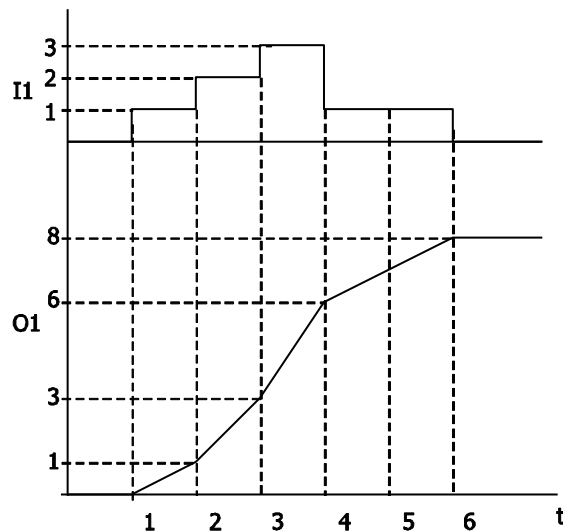

t	I1	O1	O1	O1
		i=1	i=2	i=3
1	1	0	0	0
2	2	1	0.5	0.33
3	3	3	3/2	1
4	1	6	3	2
5	1	7	3.5	2.33
6	0	8	4	2.67



Percentages [%] have two decimals.

For example: Value $12345_{IN} = 123.45\% = 1.2345$



If the change is smaller than 0.01 % per time sample, the output of the Integrator doesn't change due to the internal resolution of this function. Use smaller integration time values or higher input values to prevent this.

6.3.9 [351] Differentiator (D-element)

	Type	Function		Type	Function
I1	%	Differentiation quantity	O1	%	$O1 = P1 \times \frac{dI1}{dt}$
I2	-	-	O2	%	inverted output = -O1
I3	-	-	P1	%	Derivative action time in ms
I4	b	Master Reset	P2	-	-

Description:

The input value at I1 is differentiated.

The derivative action time indicates how long a linear ramp must rise until it has the same value as the output of the differentiator.

$$O1 = -O2 = P1 \times \frac{dI1}{dt}$$

If an integrator and a differentiator are connected in series, a p-element is obtained with amplification $V = Td/Ti$.

If, for example, the output value is limited in the case of a jump at the input, the limited value will be output longer.

In the case of a jump at the input, the jump height/sampling time is assumed as the ramp gradient.

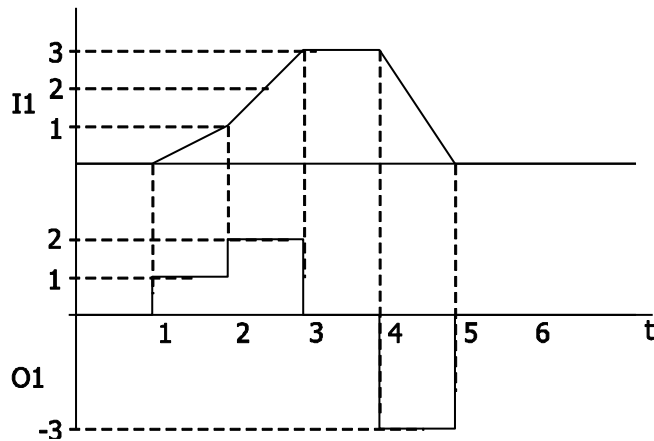

As long as status TRUE is present at I4 (Master Reset), the output value O1 is 0.



Percentages [%] have two decimals.

For example: Value 12345_{IN} = 123.45% = 1.2345

6.3.10 [360] Absolute value function

	Type	Function		Type	Function
I1	%	Input value	O1	%	$O1 = I1 $
I2	-	-	O2	%	inverted output = -O1
I3	-	-	P1	-	-
I4	b	Master Reset	P2	-	-

Description:

The absolute value of the input value at I1 is calculated. The output value at O1 is always positive.

$$O1 = -O2 = |I1|$$

As long as status TRUE is present at I4 (Master Reset), the output value O1 is 0.



Percentages [%] have two decimals.

For example: Value 12345_{IN} = 123.45% = 1.2345

6.3.11 [361] X², SQR (I1)

	Type	Function		Type	Function
I1	%	Input value	O1	%	$O1 = I1^2$
I2	-	-	O2	%	inverted output = -O1
I3	-	-	P1	-	-
I4	b	Master Reset	P2	%	Limitation of output value

Description:

The input value at I1 is squared.

$$O1 = -O2 = I1^2$$

Example: I1 = 130.00%; O1 = I1² = 169.00%

The output value is limited to the adjusted value of P2.

As long as status TRUE is present at I4 (Master Reset), the output value O1 is 0.



Percentages [%] have two decimals.
For example: Value 12345_{IN} = 123.45% = 1.2345

6.3.12 [362] X³, (Cube (I1))

	Type	Function		Type	Function
I1	%	Input value	O1	%	$O1 = I1^3$
I2	-	-	O2	%	inverted output = -O1
I3	-	-	P1	-	-
I4	b	Master Reset	P2	%	Limitation of output value

Description:

The input value at I1 is cubed.

$$O1 = -O2 = I1^3$$

Example: I1 = 130.00%; O1 = I1³ = 219.70%

The output value is limited to ±P2.

As long as status TRUE is present at I4 (Master Reset), the output value O1 is 0.



Percentages [%] have two decimals.
For example: Value 12345_{IN} = 123.45% = 1.2345

6.3.13 [363] √X, square root of I1

	Type	Function		Type	Function
I1	%	Input value	O1	%	$O1 = \sqrt{I1}$
I2	-	-	O2	%	inverted output = -O1
I3	-	-	P1	-	-
I4	b	Master Reset	P2	%	Limitation of output value

Description:

The square root is calculated from the input value at I1.

$$O1 = -O2 = \sqrt{I1}$$

Note:

Since the square root of a negative number has no real result, the square root of the absolute value of the input value is worked out and the sign is applied to the output value.

$$O1 = \sqrt{|I1|}; \quad \begin{array}{l} +I1 \Rightarrow O1 = +\sqrt{|I1|} \\ -I1 \Rightarrow O1 = -\sqrt{|I1|} \end{array}$$

Example: Positive input value I1 = 130.00% O1 = 114.02%

Negative input value I1 = -130.00% O1 = -114.02%

The output value is limited to ±P2.

As long as status TRUE is present at I4 (Master Reset), the output value O1 is 0.



Percentages [%] have two decimals.
For example: Value 12345_{IN} = 123.45% = 1.2345

If position values are used as input quantities instead of percentages, this will be interpreted as follows:

$$\frac{22000 \text{ u} \times [\text{FALSE}] \times 10}{1200 \text{ u} \times 10} = \frac{22}{1,2} = 18,3333 = 1833,33\%$$

$$\Rightarrow O1 = 367,67\% \text{ (Begrenzung)}, O2 = 0,33\%$$

Parameters P1 and P2 can also be used to scale the result:

O1 = Result "in front of decimal point"/scaling P1 (division)

O2 = Result "behind decimal point"/scaling P2 (multiplication)

6.4 Controller

Controllers can be built up from individual elements. This can be used for limiting the output values of the individual elements.

6.4.1 [370] P controller

	Type	Function		Type	Function
I1	%	Input (reference value)	O1	%	$O1 = P1 \times (I1 - I2)$
I2	%	Input (actual value)	O2	%	inverted output = -O1
I3	-	-	P1	i	P amplification (x.xx)
I4	b	Master Reset	P2	%	Limitation of output value

Description:

The control deviation (I1- I2) is multiplied by the amplification P1.

$$O1 = -O2 = P1 \times (I1 - I2)$$

The output value is limited to $\pm P2$.

As long as status TRUE is present at I4 (Master Reset), the output value I1 is 0.



Percentages [%] have two decimals.

For example: Value $12345_{IN} = 123.45\% = 1.2345$

The amplification is entered with two decimals:

displayed value 123 = function value 1.23

6.4.2 [371] PI controller (Tn in milliseconds)

	Type	Function		Type	Function
I1	%	Input (reference value)	O1	%	$O1 = P1 \times (I1 - I2) + \frac{P1}{P2} \int (I1 - I2) dt$
I2	%	Input (actual value)	O2	%	inverted output = -O1
I3	%	Limitation of output values	P1	i	P amplification
I4	b	Master Reset	P2	i	Integral time in ms

Description:

The control deviation (I1- I2) is multiplied by the amplification P1. The I controller adds up the control deviation over time. The I component is added. When the integral time has elapsed, the I component reaches the same value again so that the output value is doubled.

$$O1 = -O2 = P1 \times (I1 - I2) + \frac{P1}{P2} \int (I1 - I2) dt$$

The output value is limited to the value at input I3.

As long as status TRUE is present at I4 (Master Reset), the output value I1 and the I component are 0.



Percentages [%] have two decimals.

For example: Value $12345_{IN} = 123.45\% = 1.2345$

6.4.3 [372] PI controller (Tn in seconds)

	Type	Function		Type	Function
I1	%	Input (reference value)	O1	%	$O1 = P1 \times (I1 - I2) + \frac{P1}{P2} \int (I1 - I2) dt$
I2	%	Input (actual value)	O2	%	inverted output = -O1
I3	%	Limitation of output values	P1	i	P amplification
I4	b	Master Reset	P2	i	Integral time in s

Description:

The control deviation (I1 - I2) is multiplied by the amplification P1. The I controller adds up the control deviation over time. The I component is added. When the integral time has elapsed, the I component reaches the same value again so that the output value is doubled.

$$O1 = -O2 = P1 \times (I1 - I2) + \frac{P1}{P2} \int (I1 - I2) dt$$

The output value is limited to the value at input I3.

As long as status TRUE is present at I4 (Master Reset), the output value O1 and the I component are 0.



Percentages [%] have two decimals.

For example: Value $12345_{IN} = 123.45\% = 1.2345$

6.4.4 [373] PD(T1) controller

	Type	Function		Type	Function
I1	%	Input (reference value)	O1	%	$O1 = P1 \times (I1 - I2) + P1 \times P2 \times \frac{d(I1 - I2)}{dt}$
I2	%	Input (actual value)	O2	%	inverted output = -O1
I3	%	Limitation of output values	P1	i	P amplification [x.xx]
I4	b	Master Reset	P2	i	Derivative action time in ms

Description:

The control deviation (I1- I2) is multiplied by the amplification P1. The D component is added. The P amplification P1 is set in the unit of hundredth, therefore P1 = 100 means an amplification factor of 1.00.

$$O1 = -O2 = P1 \times (I1 - I2) + P1 \times P2 \times \frac{d(I1 - I2)}{dt}$$

The output value is limited to the value at input I3.

The input can be combined with a fixed value, for example.

As long as status TRUE is present at I4 (Master Reset), the output value O1 is 0.

The time constant T1 of the PD(T1) controller corresponds to the sampling time.



Percentages [%] have two decimals.

For example: Value $12345_{IN} = 123.45\% = 1.2345$

6.4.5 [374] PID(T1) controller (Tn in milliseconds)

	Type	Function		Type	Function
I1	%	Input (reference value)	O1	%	$O1 = (I1 - I2) + \frac{1}{P1} \int (I1 - I2) dt + P2 \times \frac{d(I1 - I2)}{dt}$
I2	%	Input (actual value)	O2	%	inverted output = -O1
I3	%	Limitation of output values	P1	i	Integral time in ms
I4	b	Master Reset	P2	i	Derivative action time in ms

Description:

The control deviation (I1 – I2) is multiplied by the amplification (=1). The I component and

$$O1 = -O2 = (I1 - I2) + \frac{1}{P1} \int (I1 - I2) dt + P2 \times \frac{d(I1 - I2)}{dt}$$

the D component are added.

In instruction "374 PID(T1) controller", the integral time P1 (I component) and the derivative action time P2 (D component) can be adjusted. The amplification P1 is set to the fixed value 1. In order to set up another amplification, a P controller (instruction "370 - P controller) must be connected to the input of the PID(T1) controller.



In the P controller (instruction 370), P1 is the amplification. In the PID(T1) controller, P1 is the integral time.

PID controller and series-connected P controller for setting up an amplification:

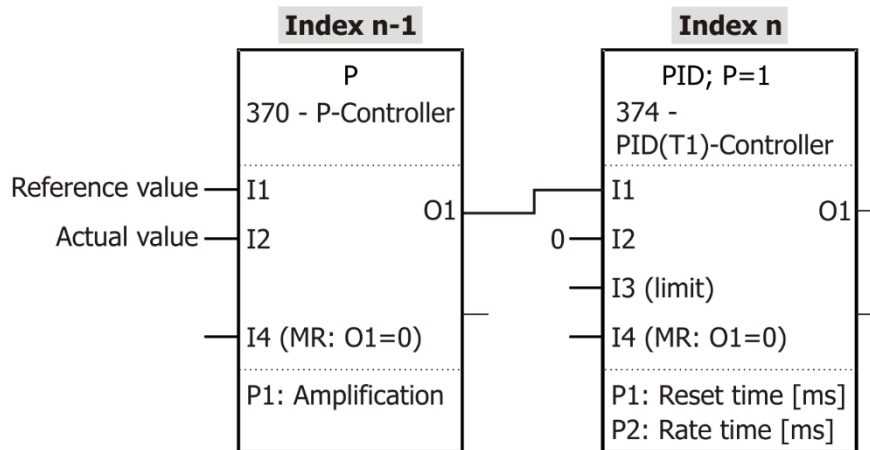

$$O1 = -O2 = P1_{n-1} \times (I1_{n-1} - I2_{n-1}) + \frac{P1_{n-1}}{P1_n} \int (I1_{n-1} - I2_{n-1}) dt + P1_{n-1} \times P2_n \times \frac{d(I1_{n-1} - I2_{n-1})}{dt}$$

Set amplification in P controller.

Set integral time and derivative action time in PID controller.



If the amplification of the PID controller is to be 1, no P controller must be connected in series.

If a value of 100.00% is applied to the input in the form of a jump, the output value is the total of the three components:

P component: 100.00% constant

I component: Ramp reaching the value of 100.00% after integral time P1.

D component: Pulse of length of a sampling step and level

$$\frac{P2}{T1} \times \tau \rightarrow 100\%; \quad T1 = \text{sampling time}$$

If the pulse level exceeds the limitation of the output value, the pulse will be output longer.

The output value is limited to the value at input I3.

Input I3 can be combined with a fixed value, for example.

As long as status TRUE is present at I4 (Master Reset), the output value O1 and the I component are 0.



Percentages [%] have two decimals.

For example: Value 12345_{IN} = 123.45% = 1.2345

6.4.6 [375] PID(T1) controller (Tn in seconds)

Type	Function	Type	Function
I1	% Input (reference value)	O1	$O1 = (I1 - I2) + \frac{1}{P1} \int (I1 - I2) dt + P2 \times \frac{d(I1 - I2)}{dt}$
I2	% Input (actual value)	O2	inverted output = -O1
I3	% Limitation of output values	P1	Integral time in s
I4	b Master Reset	P2	Derivative action time in ms

Description:

The control deviation (I1 – I2) is multiplied by the amplification (=1). The I component and

$$O1 = -O2 = (I1 - I2) + \frac{1}{P1} \int (I1 - I2) dt + P2 \times \frac{d(I1 - I2)}{dt}$$

the D component are added.

In instruction "375 PID(T1) controller", the integral time P1 (I component) and the derivative action time P2 (D component) can be adjusted. The amplification P1 is set to the fixed value 1. In order to set up another amplification, a P controller (instruction "370 - P controller) must be connected to the input of the PID(T1) controller.



In the P controller (instruction 370), P1 is the amplification. In the PID(T1) controller, P1 is the integral time.

PID controller and series-connected P controller for setting up an amplification:

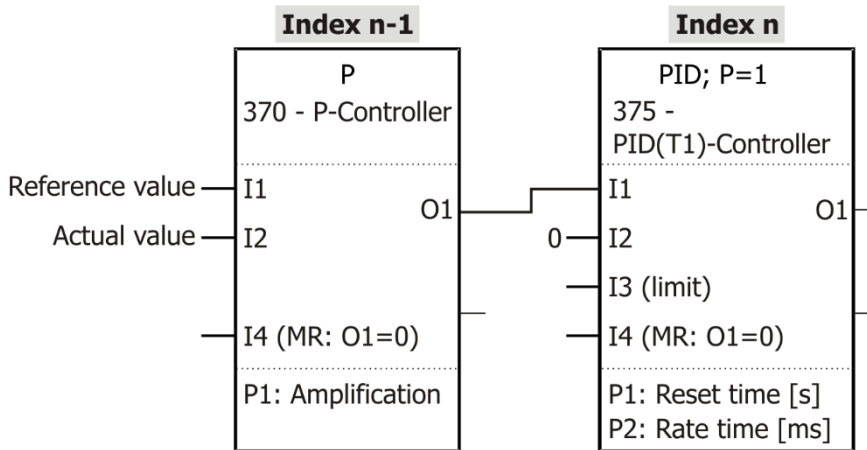

Index n-1:

Index n:

$$O1 = -O2 = P1_{n-1} \times (I1_{n-1} - I2_{n-1}) + \frac{P1_{n-1}}{P1_n} \int (I1_{n-1} - I2_{n-1}) dt + P1_{n-1} \times P2_n \times \frac{d(I1_{n-1} - I2_{n-1})}{dt}$$

Set amplification in P controller.

Set integral time and derivative action time in PID controller.



If the amplification of the PID controller is to be 1 , no P controller must be connected in series.

If a value of 100.00% is applied to the input in the form of a jump, the output value is the total of the three components:

P component: 100.00% constant

I component: Ramp reaching the value of 100.00% after integral time P1.

D component: Pulse of length of a sampling step and level

$$\frac{P2}{T1} \times \tau \rightarrow 100\%; \quad T1 = \text{Sampling time}$$

If the pulse level exceeds the limitation of the output value, the pulse will be output longer.

The output value is limited to the value at input I3.

The input can be combined with a fixed value, for example.

As long as status TRUE is present at I4 (Master Reset), the output value O1 and the I component are 0.



Percentages [%] have two decimals.

For example: Value $12345_{IN} = 123.45\% = 1.2345$

6.5 Filters

6.5.1 [380] PT1 element

	Type	Function		Type	Function
I1	%	Input value	O1	%	$O1 = I1 \times (1 - e^{-\frac{t}{P1}})$
I2	%	Start value	O2	%	inverted output = -O1
I3	b	Master Set	P1	i	Filter time constant in ms
I4	b	Master Reset	P2	-	-

Description:

The input value at I1 is filtered.

$$O1 = -O2 = I1 \times (1 - e^{-\frac{t}{P1}})$$

- The filter time constant P1 indicates how long it takes in the case of a constant input value until the output value (starting from zero) reaches 63% of the input value.
- Master Set: TRUE sets the output to the start value. The start value can be defined via input I2.
- Master-Reset: TRUE sets the output to 0.
- Master Reset has priority over Master Set.

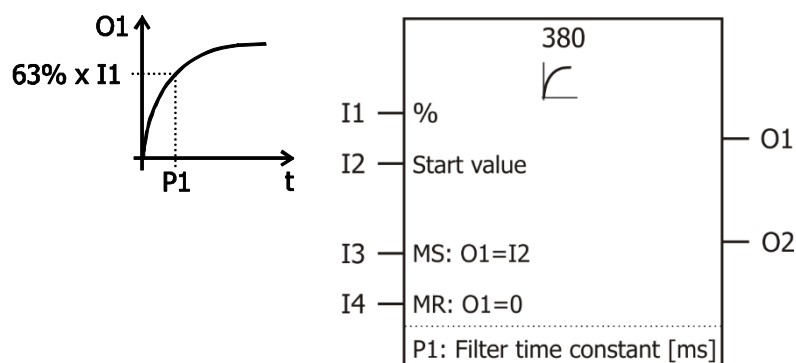

If the filter is to be stopped, input 2 must be combined with the output and the Master Set input (I3) must be activated.

I2=O1, I3=TRUE

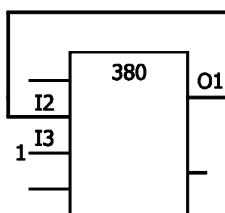

Percentages [%] have two decimals.

For example: Value $12345_{IN} = 123.45\% = 1.2345$

6.5.2 [381] Time average

	Type	Function		Type	Function
I1	%	Input value	O1	%	$O1 = \frac{\sum_{i=1}^n I_i}{n} = \frac{I_1 + I_2 + I_3 + \dots + I_n}{n}$
I2	-	-	O2	%	inverted output = -O1
I3	-	-	P1	-	-
I4	b	Master Reset	P2	-	-

Description:

The function determines the average value over a period of time. The output value is updated with each cycle.

Master Reset is FALSE: The output value is the average of all input values since the last negative edge from Master Reset.

Master Reset is TRUE: The output value is the same as the input value.

$$O1 = -O2 = \frac{\sum_{i=1}^n I_i}{n} = \frac{I_1 + I_2 + I_3 + \dots + I_n}{n}$$

I4	O1=
0	Average of I4
1	I4



Percentages [%] have two decimals.

For example: Value 12345_{IN} = 123.45% = 1.2345

6.5.3 [382] Ramp limitation

	Type	Function		Type	Function
I1	%	Input value	O1	%	I1 with limited ramp gradient
I2	%	Start value	O2	%	inverted output = -O1
I3	b	Master Set	P1	%	Ramp gradient [% per time unit]
I4	b	Master Reset	P2	i	Time unit: 1: [ms], 2: [s], 3: [min]

Description:

The output value follows the input value at a limited ramp gradient.

P1 indicates the percentage by which the output value may change per unit of time.

P2 indicates the unit of P1:

- 1: in percent per millisecond [%/ms],
- 2: in percent per second [%/s],
- 3: in percent per minute [%/min].

Master Set: TRUE sets the output to the start value. The start value can be defined via input I2.

Master-Reset: TRUE sets output O1 to 0.

Master Reset has priority over Master Set.

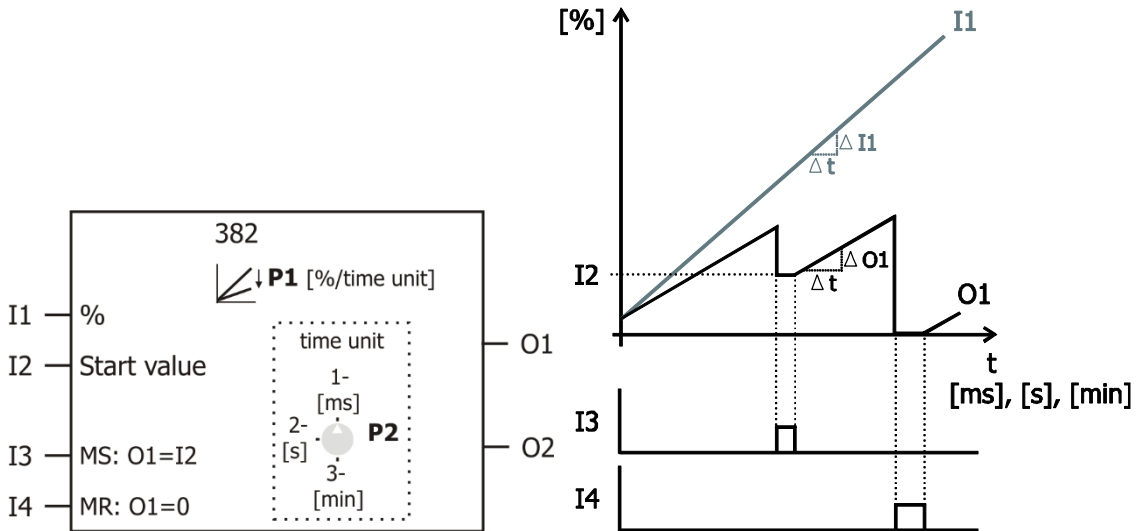

I3	I4	O1=	
0	0	I1	(ramp gradient limited)
0→1	0	I2	
x	0→1	0	

If the ramp is to be stopped, input 2 must be combined with the output and the Master Set input (I3) must be activated.

I2=O1, I3=TRUE

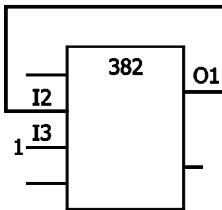

Percentages [%] have two decimals.
For example: Value 12345_{IN} = 123.45% = 1.2345

6.5.4 [383] Spike filter (average of three)

Type	Function	Type	Function
I1	% Input value	O1	% Output average of $I1_{(tn-2)}, I1_{(tn-1)}, I1_{(tn)}$
I2	% Start value	O2	% inverted output = -O1
I3	b Master Set	P1	-
I4	b Master Reset	P2	-

Description:

The input value at I1 is filtered.

The average of the current input value and the two previous input values is output. In this way individual input spikes are suppressed.

Master Set: TRUE sets the output to the start value. The start value can be defined via input I2.

Master-Reset: TRUE sets the output to 0.

Master Reset has priority over Master Set.

I3	I4	O1=
0	0	I1 (average of last 3 values)
0→1	0	I2
x	0→1	0

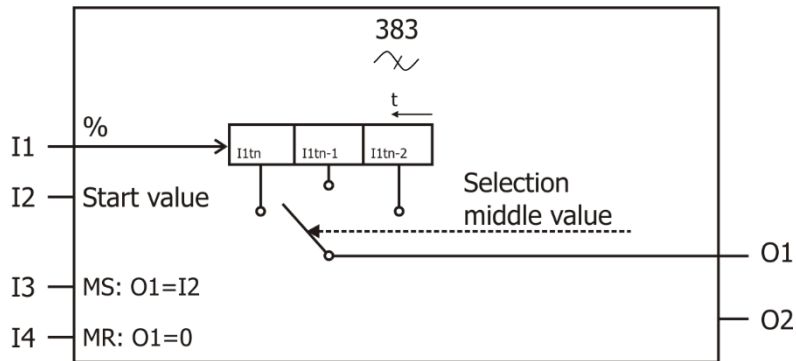

Percentages [%] have two decimals.

For example: Value $12345_{IN} = 123.45\% = 1.2345$

6.6 Analog switch

6.6.1 [390] Analog multiplexer (data set number)

	Type	Function		Type	Function
I1	%	input value 1	O1	%	I1, I2, I3 or I4
I2	%	input value 2	O2	%	inverted output = -O1
I3	%	input value 3	P1	-	-
I4	%	input value 4	P2	-	-

Description:

Depending on the active data set (parameter *active data set* **249**), one of the input values is output.

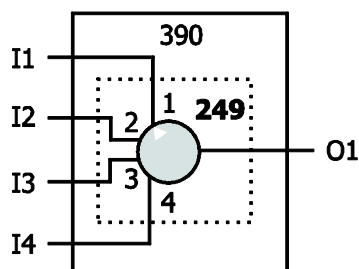

Active data set 249	O1=
1	I1
2	I2
3	I3
4	I4



Percentages [%] have two decimals.

For example: Value $12345_{IN} = 123.45\% = 1.2345$

6.6.2 [391] Analog changeover switch

	Type	Function		Type	Function
I1	%	input value 1	O1	%	I1, I2, P1 or P2
I2	%	input value 2	O2	%	inverted output = -O1
I3	b	Selection of value 1 or	P1	%	Fixed value 1
I4	b	Selection of I or P	P2	%	Fixed value 2

Description:

One of the values I1, I2, P1 or P2 is output. Via I4, it is defined if an input value (I1, I2) or a fixed value (P1, P2) is output. Via I3 it is defined if value 1 or 2 is output.

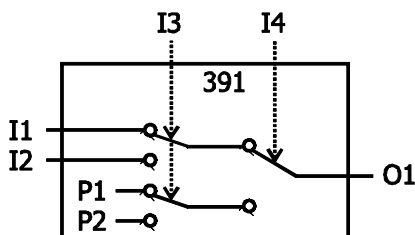

The input values and fixed values are selected according to the following table:

I3	I4	O1=
0	0	I1
1	0	I2
0	1	P1
1	1	P2



Percentages [%] have two decimals.

For example: Value 12345_{IN} = 123.45% = 1.2345

6.6.3 [392] MUX for position values (data set number), Multiplexer

	Type	Function		Type	Function
I1	Pos.	input value 1	O1	Pos.	I1, I2, I3 or I4
I2	Pos.	input value 2	O2	Pos.	
I3	Pos.	input value 3	P1	-	High word
I4	Pos.	input value 4	P2	-	

Description:

Depending on the active data set (parameter *active data set* **249**), one of the input values is output at the output.

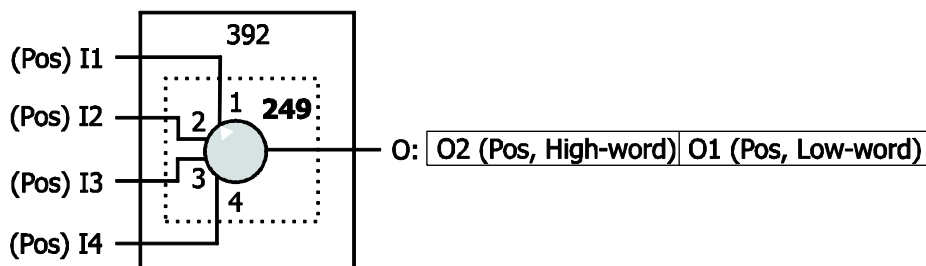

Active data set 249	O=
1	I1
2	I2
3	I3
4	I4

O = O2 | O1 = High – word | Low – word



Output value O2 is **not** the inverted value of O1.

The output can be combined with inputs for position values (Long).

The function can also be used for ramp settings in configurations x40.

The output has value 0 if an input combined with FALSE is selected by the active data set.

6.6.4 [393] Changeover switch for position values (Long)

	Type	Function		Type	Function
I1	Pos	input value 1	O1	Pos	I1, I2 or (P2 P1)
I2	Pos	input value 2	O2	Pos	
I3	b	Selection value 1 or 2	P1	Pos	Fixed value P
I4	b	Selection of I or P	P2	Pos	

Description:

One of the values I1, I2, or P is output. Via I4 it is defined if an input value or the fixed value is output. Via I3 it is defined if value 1 or 2 is output.

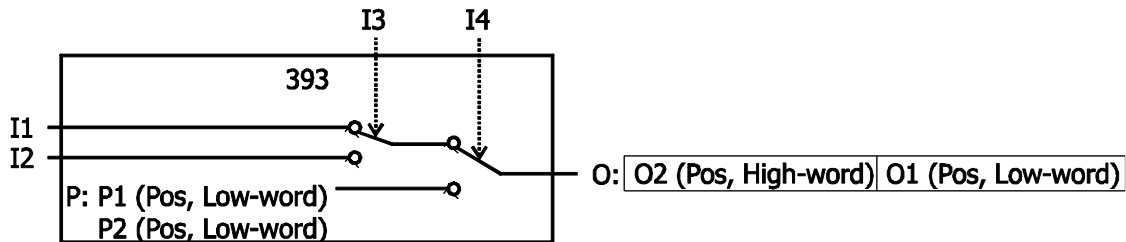

The output value is determined according to the following table:

I3	I4	O=
0	0	I1
1	0	I2
x	1	P2 P1

P2 | P1 = High – word | Low – word



Output value O2 is **not** the inverted value of O1.

The output can be combined with inputs for position values (Long).

The function can also be used for ramp settings in configurations x40.

The availability of configuration x40 depends on the device series.

6.7 Parameter access

6.7.1 Writing parameters

Parameters can be written from the PLC functions. This is done in two steps.

- The PLC function puts the write request, including all data, on a list.
- This list is processed in non-realtime system. In this process, redundant write commands on the same parameter are deleted. The list can contain a maximum of 8 write commands.

The output is TRUE if the list is full and cannot accept any more write commands.

If the parameter number is outside of the range 0 ... 1599, only the status of the buffer is checked and the output is set, if applicable.

Any errors during the write process will be ignored.

If input I4 "Wait" is TRUE, zero operations (NOP) will be inserted if the write buffer is full until the write command can be entered in the buffer. If input I4 "Wait" is FALSE, write commands may be lost in the case of a buffer overflow.

If input I2 "Delete buffer" is TRUE, the write buffer will be deleted first before the new write command is entered.

Output O1 turns TRUE if the write buffer is full.

The target parameter of the write command is defined by P1. The target data set is defined by P2.

6.7.1.1 [401] Write frequency parameter

	Type	Function		Type	Function
I1	%	input value 1	O1	b	Buffer full
I2	b	Delete buffer	O2	b	inverted output = -O1
I3	b	Write release	P1	i	Parameter number
I4	b	Wait until writing	P2	i	Data set (0 ... 9) or index

Description:

The input value is converted from percent to Hz and written as long parameter.

I1[%] → I1[Hz]

123.45% = 123.45 Hz

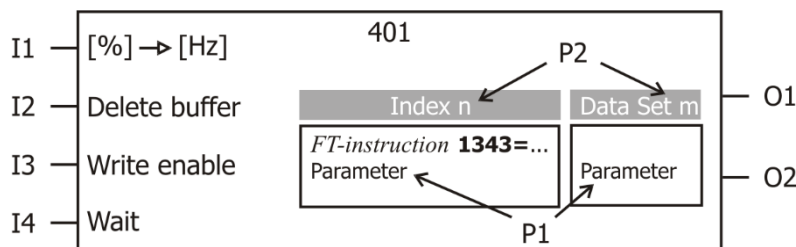

6.7.1.2 [402] Write current parameter

	Type	Function		Type	Function
I1	%	input value 1	O1	b	Buffer full
I2	b	Delete buffer	O2	b	inverted output = -O1
I3	b	Write release	P1	i	Parameter number
I4	b	Wait until writing is finished	P2	i	Data set (0 ... 9) or index

Description:

The input value is converted from percent to A and written as int parameter.

I1[%] → I1[A]

123.45% = 123.45 A

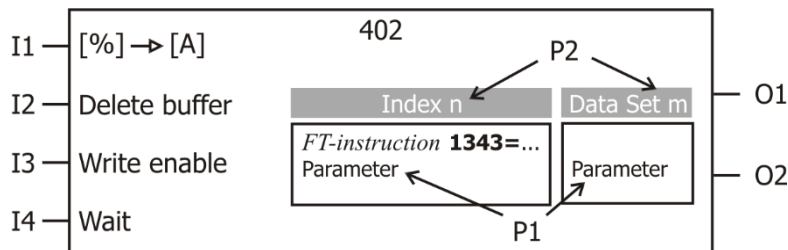

6.7.1.3 [403] Write voltage parameter (eff.)

	Type	Function		Type	Function
I1	%	input value 1	O1	b	Buffer full
I2	b	Delete buffer	O2	b	inverted output = -O1
I3	b	Write release	P1	i	Parameter number
I4	b	Wait until writing is finished	P2	i	Data set (0 ... 9) or index

Description:

The effective value at the input is converted from percent to V and written as int parameter.

I1[%] → I1[V]

123.45% = 123.45 V

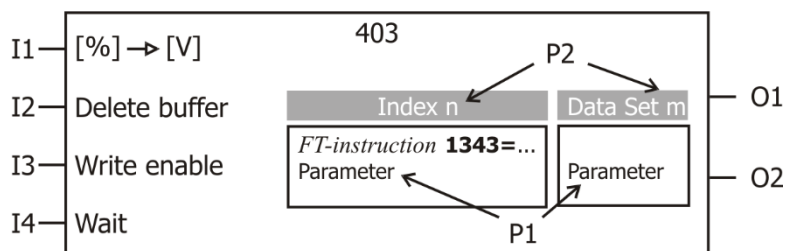

6.7.1.4 [404] Write voltage parameter (peak)

	Type	Function		Type	Function
I1	%	input value 1	O1	b	Buffer full
I2	b	Delete buffer	O2	b	inverted output = -O1
I3	b	Write release	P1	i	Parameter number
I4	b	Wait until writing is finished	P2	i	Data set (0 ... 9) or index

Description:

The peak value at the input is converted from percent to V and written as int parameter.

I1[%] → I1[V]

123.45% = 123.45 V

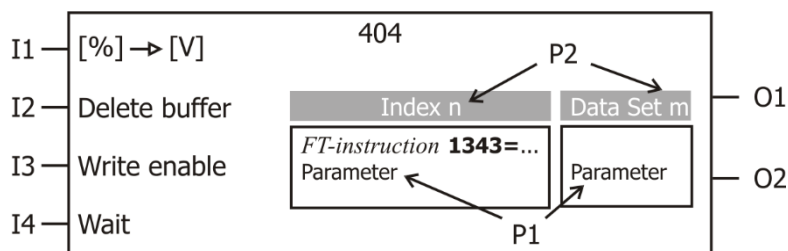

6.7.1.5 [405] Write percentage parameter

	Type	Function		Type	Function
I1	%	input value 1	O1	b	Buffer full
I2	b	Delete buffer	O2	b	inverted output = -O1
I3	b	Write release	P1	i	Parameter number
I4	b	Wait until writing is finished	P2	i	Data set (0 ... 9) or index

Description:

The input value is not changed and written as int parameter. In this way, this function can also be used for any other (int) parameter types.

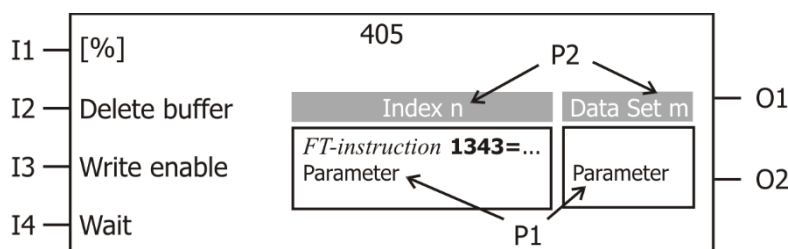

6.7.1.6 [406] Write position parameter

	Type	Function			Type	Function
I1	Pos	Input value	Low word	O	b	Buffer full
I2	Pos	value	High word	O	b	inverted output = -O1
I3	b	Write enable		P1	i	Parameter number
I4	b	Wait until writing is finished		P2	i	Data set (0 ... 9) or index

Description:

The input value is not changed and written as long parameter. In this way, this function can be used for any long parameter types.

O1 = I2|I1 (High-word|Low-word)

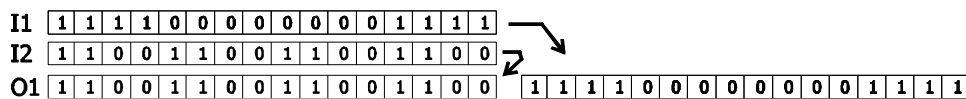

(For the bits, example values are entered here.)

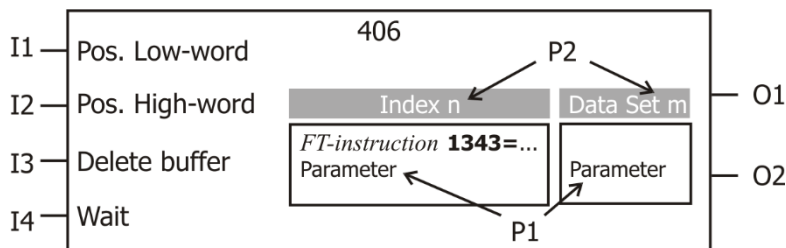

6.7.1.7 [407] Write long parameter

	Type	Function			Type	Function
I1	%	Input value	Low word	O1	b	Buffer full
I2	%		High word	O2	b	inverted output = -O1
I3	b	Write enable		P1	i	Parameter number
I4	b	Wait until writing is finished		P2	i	Data set (0 ... 9) or index

Description:

The input value is put together of low-word and high-word, not changed and output as long parameter. In this way, this function can be used for any long parameter types.

O1 = I2|I1 (High-word|Low-word)

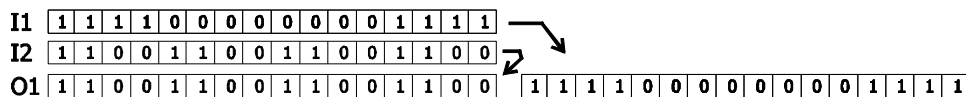

(For the bits, example values are entered here.)

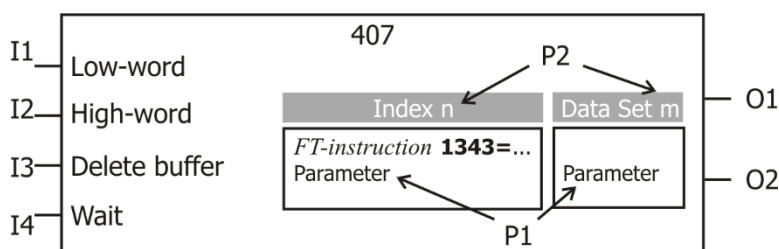

6.7.1.8 [408] Write word parameter

	Type	Function		Type	Function
I1		input value 1	O1		Buffer full
I2	b	Delete buffer	O2	b	inverted output = -O1
I3	b	Write release	P1	i	Parameter number
I4	b	Wait until writing is finished	P2	i	Data set (0 ... 9) or index

Description:

The input value is not changed and written as int parameter. In this way, this function can also be used for any other (int) parameter types.

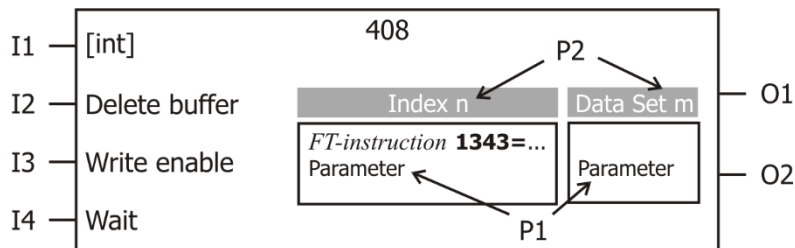

6.7.2 Reading parameters

Read access enables direct reading of all parameters of the frequency inverter. This is useful if the parameter is not connected to a source. Since the read access is effected to the non-realtime system of the frequency inverter, an instruction may take longer than 1 ms. The instruction is processed for the duration of the parameter access even if this takes longer than 1 ms.

If a non-permissible data set or index is selected, it will be replaced by one of the following data sets or indices.

Data Set/ Index	Data set related parameters	Non-data set related parameters
0	Instead, data set 1 is used. Instead, index 1 is used.	Data set 0
1...4/1...max. index	Value of data set 1...4 Value from index 1...max. Index	Data set 0
Invalid value	Instead, data set 1 (or index 1) is used.	Data set 0

All data sets are accessed from the RAM. Internal access to the EEPROM and RAM is done in the same way.

6.7.2.1 [421] Read frequency parameter

	Type	Function		Type	Function
I1	-	-	O1	%	Parameter value [Hz]
I2	-	-	O2	%	inverted output = -O1
I3	b	Release read access	P1	i	Parameter number
I4	-	-	P2	i	Data set (0 ... 4)/index

Description:

The function reads the value of the parameter set up in P1 "Parameter number" and P2 "Data set/index". The value is converted to a frequency value. Via Input I3 read access is enabled.

I3 = 0: No read access.

I3 = 1: The parameter value is read. The instruction is executed until the value is read.

6.7.2.2 [422] Read current parameter

	Type	Function		Type	Function
I1	-	-	O1	%	Parameter value [A]
I2	-	-	O2	%	inverted output = -O1
I3	b	Release read access	P1	i	Parameter number
I4	-	-	P2	i	Data set (0 ... 4)/index

Description:

The function reads the value of the parameter set up in P1 "Parameter number" and P2 "Data set/index". The value is converted to a current value. Via Input I3 read access is enabled.

I3 = 0: No read access.

I3 = 1: The parameter value is read. The instruction is executed until the value is read.

6.7.2.3 [423] Read voltage parameter (eff.)

	Type	Function		Type	Function
I1	-	-	O1	%	Parameter value [V]
I2	-	-	O2	%	inverted output = -O1
I3	b	Release read access	P1	i	Parameter number
I4	-	-	P2	i	Data set (0 ... 4)/index

Description:

The function reads the value of the parameter set up in P1 "Parameter number" and P2 "Data set/index". The value is converted to a voltage value. Via Input I3 read access is enabled.

I3 = 0: No read access.

I3 = 1: The parameter value is read. The instruction is executed until the value is read.

6.7.2.4 [424] Read voltage parameter (peak)

	Type	Function		Type	Function
I1	-	-	O1	%	Parameter value [V]
I2	-	-	O2	%	inverted output = -O1
I3	b	Release read access	P1	i	Parameter number
I4	-	-	P2	i	Data set (0 ... 4)/index

Description:

The function reads the value of the parameter set up in P1 "Parameter number" and P2 "Data set/index". The value is converted to a voltage value. Via Input I3 read access is enabled.

I3 = 0: No read access.

I3 = 1: The parameter value is read. The instruction is executed until the value is read.

6.7.2.5 [425] Read percent parameter

	Type	Function		Type	Function
I1	-	-	O1	%	Parameter value [%]
I2	-	-	O2	%	inverted output = -O1
I3	b	Release read access	P1	i	Parameter number
I4	-	-	P2	i	Data set (0 ... 4)/index

Description:

The function reads the value of the parameter set up in P1 "Parameter number" and P2 "Data set/index". The value is converted to a percent value. Via Input I3 read access is enabled.

I3 = 0: No read access.

I3 = 1: The parameter value is read. The instruction is executed until the value is read.

6.7.2.6 [426] Read position parameter

	Type	Function		Type	Function
I1	-	-	O1	%	Position
I2	-	-	O2	%	value
I3	b	Release read access	P1	i	Parameter number
I4	-	-	P2	i	Data set (0 ... 4)/index

Description:

The function reads the value of the parameter set up in P1 "Parameter number" and P2 "Data set/index". The value is converted to a position value. Via Input I3 read access is enabled.

I3 = 0: No read access.

I3 = 1: The parameter value is read. The instruction is executed until the value is read.

6.7.2.7 [427] Read long parameter

	Type	Function		Type	Function
I1	-	-	O1	%	Long value
I2	-	-	O2	%	High word
I3	b	Release read access	P1	i	Parameter number
I4	-	-	P2	i	Data set (0 ... 4)/index

Description:

The function reads the value of the parameter set up in P1 "Parameter number" and P2 "Data set/index". The value is converted to a long value. Via Input I3 read access is enabled.

I3 = 0: No read access.

I3 = 1: The parameter value is read. The instruction is executed until the value is read.

6.7.2.8 [428] Read word parameter

	Type	Function		Type	Function
I1	-	-	O1	%	Parameter value [%]
I2	-	-	O2	%	inverted output = -O1
I3	b	Release read access	P1	i	Parameter number
I4	-	-	P2	i	Data set (0 ... 4)/index

Description:

The function reads the value of the parameter set up in P1 "Parameter number" and P2 "Data set/index". The value is converted to a percent value. Via Input I3 read access is enabled.

I3 = 0: No read access.

I3 = 1: The parameter value is read. The instruction is executed until the value is read.

6.8 Limiters

6.8.1 [440] Limiter (Const.)

	Type	Function		Type	Function
I1	%	input value 1	O1	%	$O1 = I1_{P2}^{P1}$
I2	-	-	O2	%	inverted output = -O1
I3	-	-	P1	%	upper limit
I4	b	Master Reset	P2	%	lower limit

Description:

The input value at I1 is limited to P1 (upper limit) and P2 (lower limit) and output.

$$O1 = I1_{P2}^{P1}$$

As long as status TRUE is present at I4 (Master Reset), the output value O1 is 0.



P2 can only be entered as a positive value.

If $P2 > P1$, the output signal is always $\geq P2$ and P1 is no longer effective.

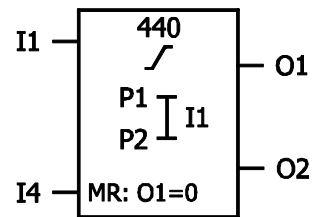
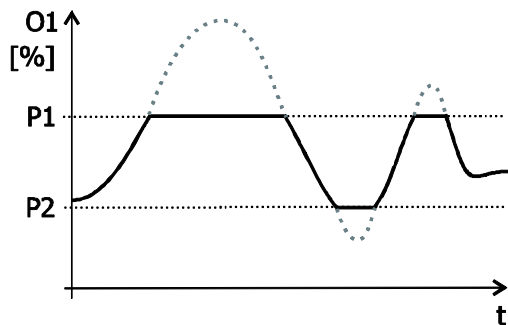

6.8.2 [441] Limiter (variable)

	Type	Function		Type	Function
I1	%	input value 1	O1	%	$O1 = I1 \begin{matrix} I2 \uparrow \\ I3 \downarrow \end{matrix}$
I2	%	upper limit	O2	%	inverted output = -O1
I3	%	lower limit	P1	-	-
I4	b	Master Reset	P2	-	-

Description:

The input value at I1 is limited to I1 (upper limit) and I2 (lower limit) and output.

$$O1 = I1 \begin{matrix} I2 \uparrow \\ I3 \downarrow \end{matrix}$$

As long as status TRUE is present at I4 (Master Reset), the output value O1 is 0.



If I3 > I2, the output signal is always ≥ I3 and I2 is no longer effective.

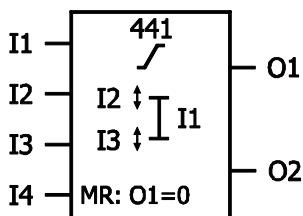
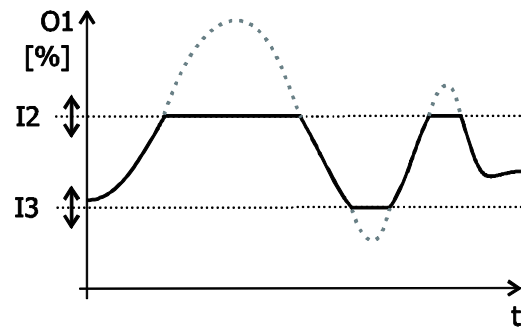
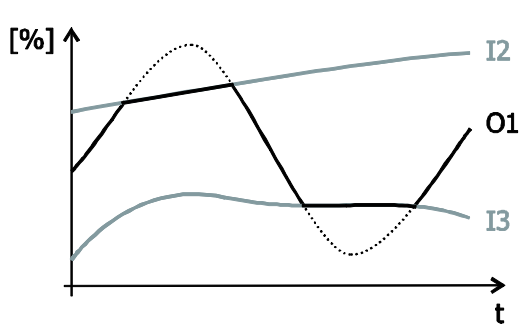

6.9 Counters

6.9.1 [450] Up/Down counter with analog output

	Type	Function		Type	Function
I1	b	Up counter	O1	%	O1= counter I1 - counter I2
I2	b	Down counter	O2	%	inverted output = -O1
I3	b	Master Set	P1	i	Steps up for 100.00%
I4	b	Master Reset	P2	i	Steps down for 100.00%

Description:

- Each positive edge at I1 increases the output value O1 by 100.00%/P1.
- Each positive edge at I2 reduces the output value O1 by 100.00%/P2.
- The output value is limited to the range 0.00% ... 100.00%.
- Master Set (I3) sets the output to 100.00%. This input has priority over edges at I1 or I2.
- Master Reset (I4) sets the output to 0.00%. This input has priority over edges at I1, I2 and Master Set I3.

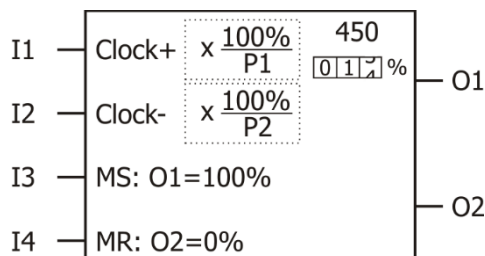

Possible applications:

Definition of reference values by means of two pushbuttons. If one of the two buttons is pressed, the reference value is to be raised or lowered by an adjustable amount.

Counting of (error) events. With each event, the counter counts up. The counter can trigger other functions, such as reporting errors occurring too often.

Example: P1 = 6, P2 = 4

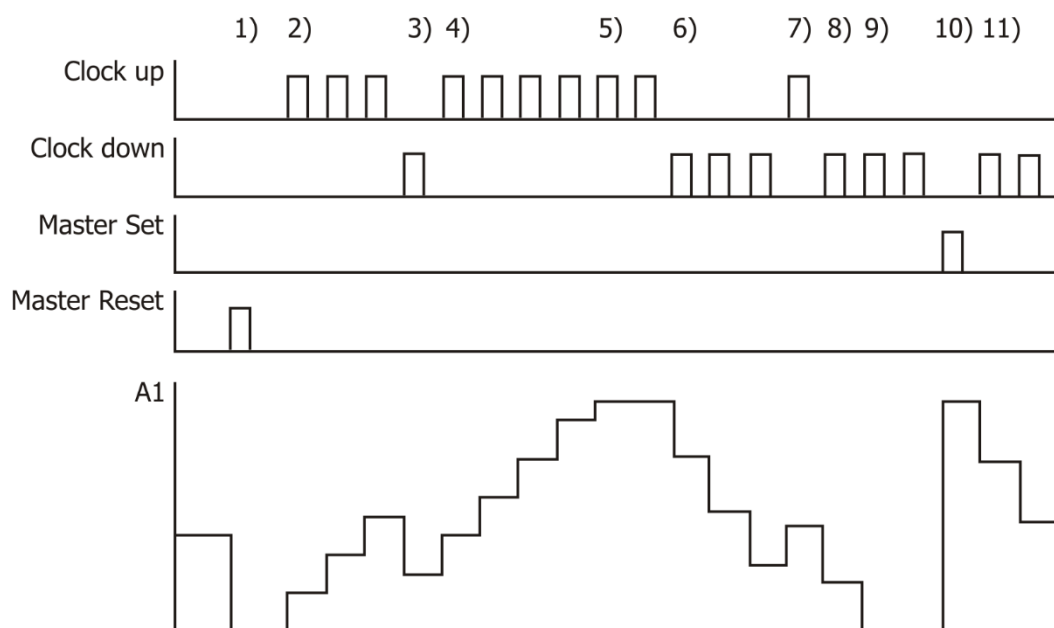

- 1) Master Reset sets output O1 to zero.
- 2) Three counting pulses up (each $100.00\%/P1 = 100.00\%/6 = 16.67\%$)
- 3) One counting pulse down. ($100.00\%/P2 = 100.00\%/4 = 25\%$)
- 4) Four counting pulses up (each $100.00\%/P1 = 100.00\%/6 = 16.67\%$)
- 5) Two counting pulses up, limitation to 100.00%
- 6) Three counting pulses down. (each $100.00\%/P2 = 100.00\%/4 = 25\%$)
- 7) One counting pulse up ($100.00\%/P1 = 100.00\%/6 = 16.67\%$)
- 8) One counting pulse down. ($100.00\%/P2 = 100.00\%/4 = 25\%$)
- 9) Two counting pulses down, limitation to zero.
- 10) Master Set sets output O1 to 100.00%.
- 11) Two counting pulses down. (each $100.00\%/P2 = 100.00\%/4 = 25\%$)



P1 and P2 are limited internally to 100.00%. If a greater value is entered, this value is replaced by 100.00%.

6.9.2 [451] Stopwatch with analog output

	Type	Function		Type	Function
I1	b	Release	O1	%	(Counting value ms)/P2
I2	b	Release, inverted	O2	%	inverted output = -O1
I3	b	Counting direction	P1	%	Start value
I4	b	Reset	P2	i	Divisor

Description:

- The stopwatch is running if I1 = TRUE and I2 = FALSE. In all other cases, the stopwatch is stopped.
- Input 3 determines the direction.
I3 = TRUE: Stop watch runs forward,
I3 = FALSE: Stopwatch runs backward.
- A positive edge at I4 sets the stopwatch (output O1) to the start value P1.
As from the next negative edge, the stopwatch will be running (if I1 = TRUE and I2 = FALSE).
- P2 determines the divisor with which the internal value is converted in the output value.
- The output value is limited to the range 0.00% ... 327.67%.

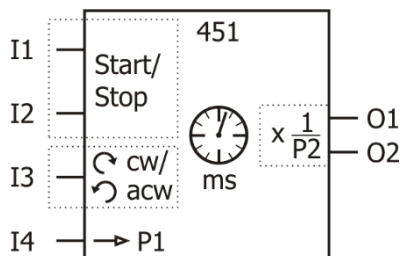

I1	I2	I3	I4	Function
1	0	1	x	Stopwatch runs forward.
1	0	0	x	Stopwatch runs backward
1	0	x	0→1	Reset to start value P1
1	0	x	1→0	Start after reset

Examples:

If I1 (release) = TRUE, I2 (release, inverted) = FALSE, I3 (counting direction) = TRUE, I4 (reset) = FALSE, the internal counter (long) is increased by one every millisecond. In order to calculate the output value, this value is divided by P2.

P2 = 1000: O1 is increased by 0.01% every second.

1) P2 = 1, time: one second (1000 ms).

$$\text{Output value: } O1 = \frac{t}{P2} = \frac{1s}{P2} = \frac{1000ms}{1 \times 100 \frac{ms}{\%}} = 10\%$$

After one second, the output reaches the value 10%.

2) P2 = 1000, time: one hour (3600 s).

$$\text{Output value: } O1 = \frac{t}{P2} = \frac{3600s}{P2} = \frac{3600000ms}{1000 \times 100 \frac{ms}{\%}} = 36\%$$

O1 is increased by 0.01% every second. After one hour, the output reaches the value 36%.

6.10 Positioning functions

The positioning can be controlled directly from the PLC functions. Via the control operation mode of the positioning, the control can be handed assigned to the PIC functions. The positioning can be controlled in the settings for parameter *Configuration 30* = "x40". In these configurations, parameter *Operation mode 1221* must be set to "1000 - Control via function table" in order to control the positioning via the PLC functions.

Output O2|O1 (High word|Low word) outputs the actual position. In operation mode 507 - "Check state", the output indicates if a motion block is running.



The "Positioning" user manual describes the positioning functions in configurations x40.

6.10.1 [501] Start motion block as single motion

	Type	Function		Type	Function
I1	Pos	Target position offset	O1	Pos	Actual position Low word
I2	%	-	O2	Pos	Actual position High word
I3	b	Release	P1	i	Number of motion block (index motion block table)
I4	b	Wait until positioning is finished	P2	-	-

Description:

The motion block selected with P1 is started. Repetitions and next motion blocks are not executed. If a motion block is still running, it will be stopped.

The position value set at input I1 (target position offset) is added to the target position set in the motion block.

				Configuration 30 = x40
		Instruction	=	Motion Block
		P1	=	Index
Target Position =	I1	+		Target Position/Distance 1202

Input I1 can be combined with position values (long).

The function is only executed if input I3 (release) is set.

If input I4 (wait) is set, further instructions will only be processed when the target position has been reached. The process cannot be stopped by other instructions or resetting I3.

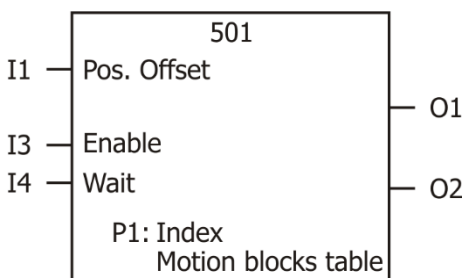

I3	I4	Function
1	0	Start motion block P1. Stopping by other instruction is possible. The target position can be changed by other instructions even if the target position has not been reached yet. The motion block is restarted.
1	1	Start motion block P1 and wait until positioning is finished.
0	0	The target position is not changed.
0	1	The target position can be changed by other instructions if no positioning is active.

6.10.2 [502] Start motion block in automatic mode

	Type	Function		Type	Function
I1	Pos	Target position offset	O1	Pos	Actual position
I2	%	-	O2	Pos	Low word
I3	b	Release			High word
I4	b	Wait until positioning is finished	P1	i	Number of motion block (index motion block table)
			P2	-	-

Description:

The motion block selected with P1 is started. Repetitions and next motion blocks are executed. If a motion block is still running, it will be stopped.

The position value set at input I1 (target position offset) is added to the target position set in the motion block.

			Configuration 30 = x40
	Instruction	=	Motion Block
	P1	=	Index
Target Position =	I1	+	Target Position/Distance 1202

Input I1 can be combined with position values (long).

The function is only executed if input I3 (release) is set.

If input I4 (wait) is set, further instructions will only be processed when the target position has been reached. The process cannot be stopped by other instructions or resetting I3.

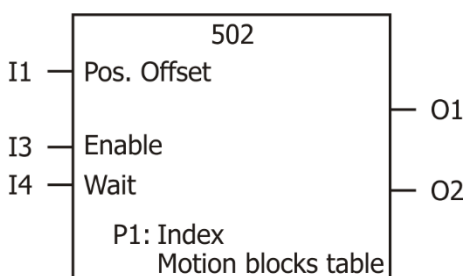

I3	I4	Function
1	0	Start motion block P1 with repetitions and next motion blocks. Stopping by other instruction is possible. The target position can be changed by other instructions even if the target position has not been reached yet. The motion block is restarted.
1	1	Start motion block P1 with repetitions and next motion blocks and wait until positioning is finished.
0	0	The target position is not changed.
0	1	The target position can be changed by other instructions if no positioning is active.

6.10.3 [503] Stop motion block

	Type	Function
I1	-	-
I2	-	-
I3	b	Release
I4	b	Wait until drive has stopped

	Type	Function	
O1	Pos	Actual position	Low word
O2	Pos		High word
P1	-	-	
P2	-	-	

Description:

The current motion block is stopped if the release at input I3 is set. The drive is stopped. If the release at I3 is reset the stopped motion block is continued and repetitions and next motion blocks are executed.

If input I4 (wait) is set, further instructions will only be processed when the drive has come to a standstill. The process cannot be stopped by other instructions or resetting I3.

The instruction is only executed if input I3 (release) is set.

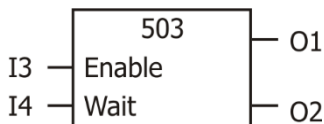

I3	I4	Function
1	0	Stop motion block and stop drive
1	1	Wait until drive has stopped
1→0	0	Continue motion block

6.10.4 [504] Continue motion block

	Type	Function
I1	-	-
I2	-	-
I3	b	Release
I4	b	Wait until motion block is finished

	Type	Function	
O1	Pos	Actual position	Low word
O2	Pos		High word
P1	-	-	
P2	-	-	

Description:

Stopped motion blocks will be continued.

The function is only executed if input I3 (release) is set.

If input I4 (wait) is set, further instructions will only be processed when the motion block (including repetitions, if applicable) or automatic sequence of motion blocks is finished. The process cannot be stopped by other instructions or resetting I3.

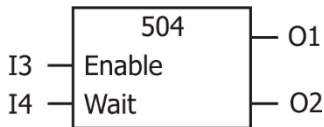

I3	I4	Function
1	0	Continue stopped motion block
1	1	Wait until the end of the motion block or the automatic sequence

6.10.5 [505] Resume motion block

	Type	Function		Type	Function
I1	-	-	O1	Pos	Actual position Low word
I2	-	-	O2	Pos	Actual position High word
I3	b	Release	P1	-	-
I4	b	Wait until motion block is finished	P2	-	-

Description:

Motion blocks stopped by error cut-off or mains off will be continued.

The function is only executed if input I3 (release) is set.

If input I4 (wait) is set, further instructions will only be processed when the motion block (including repetitions, if applicable) or automatic sequence of motion blocks is finished. The process cannot be stopped by other instructions or resetting I3.

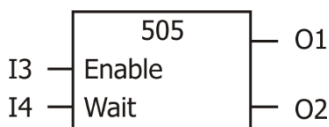

I3	I4	Function
1	0	Resume Motion Block
1	1	Wait until the end of the motion block or the automatic sequence

6.10.6 [506] Start homing

	Type	Function		Type	Function
I1	-	-	O1	Pos	Actual position Low word
I2	-	-	O2	Pos	Actual position High word
I3	b	Release	P1	i	Homing Mode
I4	b	Wait until reference position has been reached	P2	-	-

Description:

The homing operation defined in P1 is started. Running motion blocks will be stopped.

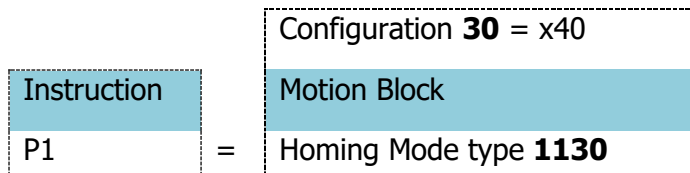

The function is only executed if input I3 (release) is set.

If input I4 (wait) is set, further instructions will only be processed when the reference position has been reached. The process cannot be stopped by other instructions or resetting I3.

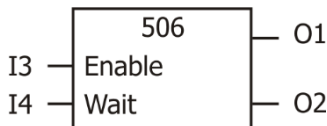

I3	I4	Function
1	0	Start homing P1.
1	1	Wait until reference position has been reached

6.10.7 [507] Check state

	Type	Function
I1	-	-
I2	-	-
I3	-	-
I4	b	Wait until motion block is finished

	Type	Function
O1	b	TRUE if motion block running
O2	b	FALSE if motion block running
P1	-	-
P2	-	-

Description:

The function sets output O1 to TRUE if a motion block is running.

If input I4 (wait) is set, further instructions will only be processed when the motion block (including repetitions, if applicable) or automatic sequence of motion blocks is finished. The process cannot be stopped by other instructions or resetting I3.

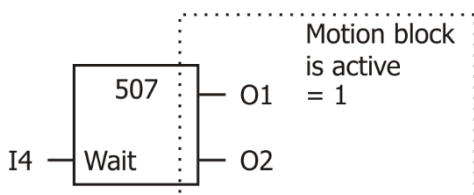

Motion block running	I4	O1=
yes	0	1
no	x	0
yes	1	Wait

6.11 Bit functions for analog input values

Each individual bit of input 1 is combined with the corresponding bits of input 2 and parameter 1 (if available to the selected function). The result is saved in the corresponding bit of the output value.

For example, bit 3 of the output value depends on

- bit 3 of input value 1 and
- bit 3 of input value 2 and
- Bit 3 of parameter 1.

Parameter 2 indicates of input value I1 is to be combined with input value I2 or parameter P1:

- P2 = 1: Combination of input value I1 with input value I2
- P2 = 2: Combination of input value I1 with parameter P1
- P2 = 3: Combination of input value I1 with input value I2 and parameter P1

Master Set sets all bits of the output value (Output = 0xFFFF).

Master Reset deletes all bits of the output value (Output = 0x0000).

At output O2, the bitwise inverted value O1 is output.

Example: O1 = 0xFF00 → O2 = 0x00FF.

6.11.1 [200] Bit NOT operation

	Type	Function		Type	Function
I1	%	input value 1	O1	%	$\overline{I1}$ (I1 bitwise inverted)
I2	-	-	O2	%	inverted output (=I1)
I3	b	Master Set	P1	-	-
I4	b	Master Reset	P2	-	-

Description:

At output 1 O1, the bitwise inverted value of input I1 is output ($O1 = \overline{I1}$).

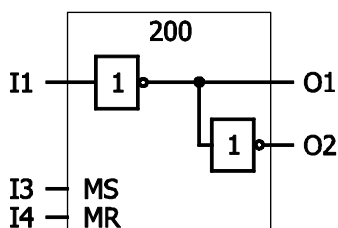

Example: I1 = 0xF00F → O1 = 0x0FF0, O2 = 0xF00F

Master Set sets all bits of the output value (Output = 0xFFFF).

Master Reset deletes all bits of the output value (Output = 0x0000).



Since output I2 output the bitwise inverted value of output O1, O2 = I1.

6.11.2 [201] Bit AND/NAND operation

	Type	Function		Type	Function
I1	%	input value 1	O1	%	O1=AND (I1 I2) if P2=1, O1=AND (I1 P1) if P2=2, O1=AND (I1 I2 P1) if P2=3
I2	%	input value 2	O2	%	inverted output = (NAND)
I3	b	Master Set	P1	%	Mask
I4	b	Master Reset	P2	i	Operation mode (1, 2 or 3)

Description:

The input value at I1 is AND combined. Via P2, you can select:

- P2 = 1: I1 and I2 are AND combined.
- P2 = 2: I1 and P1 are AND combined.
- P2 = 3: I1, I2 and P1 are AND combined.

Master Set sets all bits of the output value (Output = 0xFFFF).

Master Reset deletes all bits of the output value (Output = 0x0000).

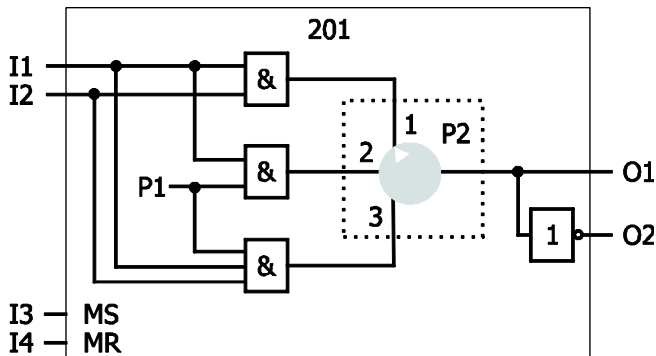

Examples:

P2	I1	I2	P1	O1	O2
1) AND (I1 I2)	0xF00F	0x0F0F	-	0x000F	0xFFFF0
2) AND (I1 P1)	0xF00F	-	0x00FF	0x000F	0xFFFF0
3) AND (I1 I2 P1)	0xF00F	0x0F0F	0x00FF	0x000F	0xFFFF0

In example 1):

I1	1	1	1	1	0	0	0	0	0	0	0	0	0	1	1	1	1	0xF00F
I2	0	0	0	0	1	1	1	1	0	0	0	0	0	1	1	1	1	0x0F0F
	& ... &																	
O1	0	0	0	0	0	0	0	0	0	0	0	0	0	1	1	1	1	0x000F

6.11.3 [202] Bit OR/NOR operation

	Type	Function		Type	Function
I1	%	input value 1	O1	%	O1=OR (I1 I2) if P2=1, O1=OR (I1 P1) if P2=2, O1=OR (I1 I2 P1) if P2=3
I2	%	input value 2	O2	%	inverted output = (NOR)
I3	b	Master Set	P1	%	Mask
I4	b	Master Reset	P2	i	Operation mode (1, 2 or 3)

Description:

The input value at I1 is OR combined. Via P2, you can select:

- P2 = 1: I1, I2 are OR combined.
- P2 = 2: I1, P1 are OR combined.
- P2 = 3: I1, I2, P1 are OR combined.

Master Set sets all bits of the output value (Output = 0xFFFF).

Master Reset deletes all bits of the output value (Output = 0x0000).

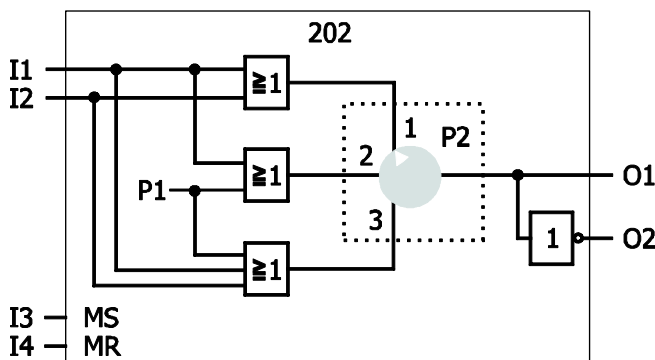

Examples:

P2	I1	I2	P1	O1	O2
1) OR (I1 I2)	0xF00F	0x0F0F	-	0xFF0F	0x00F0
2) OR (I1 P1)	0xF00F	-	0x00FF	0xF0FF	0x0F00
3) OR (I1 I2 P1)	0xF00F	0x0F0F	0x00FF	0xFFFF	0x0000

Re example 1):

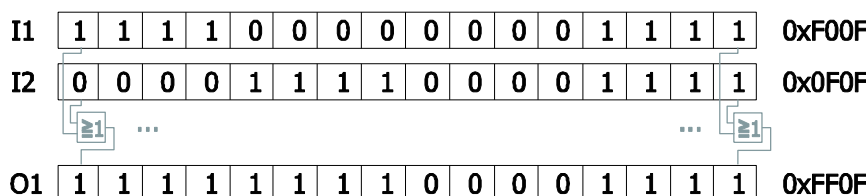

6.11.4 [203] Bit XOR/XNOR operation

	Type	Function		Type	Function
I1	%	input value 1	O1	%	O1=XOR (I1 I2) if P2=1, O1=XOR (I1 P1) if P2=2, O1=XOR {XOR (I1 I2) P1} if P2=3
I2	%	input value 2	O2	%	inverted output = (XNOR)
I3	b	Master Set	P1	%	Mask
I4	b	Master Reset	P2	i	Operation mode (1, 2 or 3)

Description:

The input value at I1 is Exclusive-OR combined. Via P2, you can select:

P2 = 1: I1, I2 are Exclusive-OR combined.

P2 = 2: I1, P1 are Exclusive-OR combined.

P2 = 3: I1, I2, P1 are Exclusive-OR combined.

Master Set sets all bits of the output value (Output = 0xFFFF).

Master Reset deletes all bits of the output value (Output = 0x0000).

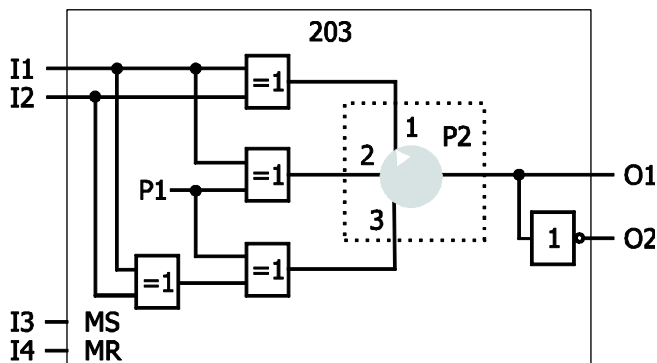

Examples:

P2	I1	I2	P1	O1	O2
1) XOR (I1 I2)	0xF00F	0x0F0F	-	0xFF00	0x00FF
2) XOR (I1 P1)	0xF00F	-	0x00FF	0xF0F0	0x0F0F
3) XOR {XOR (I1 I2) P1}	0xF00F	0x0F0F	0x00FF	0xFFFF	0x0000

Re example 1):

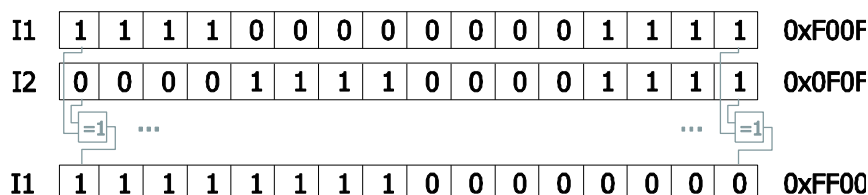

6.11.5 [210] Bit shift right

	Type	Function		Type	Function
I1	%	input value 1	O1	%	I1 bitwise shifted by P2
I2	-	-	O2	%	inverted output
I3	b	Master Set	P1	-	-
I4	b	Master Reset	P2	i	Number of shifts

Description:

The input value at I1 is shifted to the right bitwise by the number of shifts (P2). Left side is filled with zeroes.

Master Set sets all bits of the output value (Output = 0xFFFF).

Master Reset deletes all bits of the output value (Output = 0x0000).

Example	P2	I1	O1	O2
1)	1: One shift	0xF00F	0x7807	0x87F8
2)	4: Four shifts	0x00FF	0x000F	0xFFFF
3)	8: Eight shifts	0xFF00	0x00FF	0xFF00

In example 1):

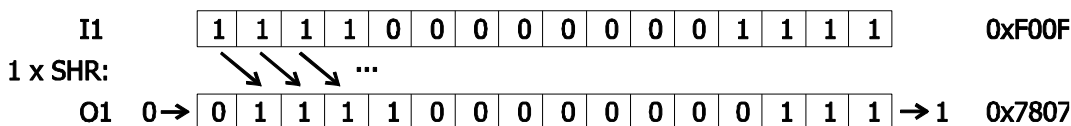

6.11.6 [211] Bit arithmetical shift right

	Type	Function		Type	Function
I1	%	input value 1	O1	%	I1 bitwise shifted by P2, sign bit is maintained
I2	-	-	O2	%	inverted output
I3	b	Master Set	P1	-	-
I4	b	Master Reset	P2	i	Number of shifts

Description:

The input value at I1 is shifted to the right bitwise by the number of shifts (P2). The most significant bit (sign bit) is maintained.

Master Set sets all bits of the output value (Output = 0xFFFF).

Master Reset deletes all bits of the output value (Output = 0x0000).

Example	P2	I1	O1	O2
1)	1: One shift	0xF00F	0xF807	0x07F8
2)	4: Four shifts	0x00FF	0x000F	0xFFFF
3)	8: Eight shifts	0xFF00	0xFFFF	0x0000

In example 1):

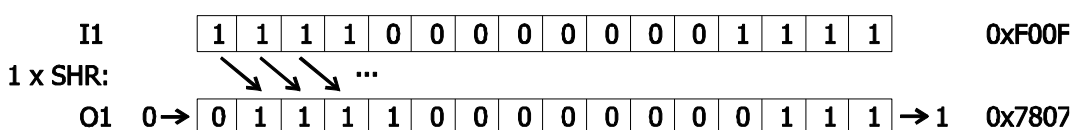

In example 1):

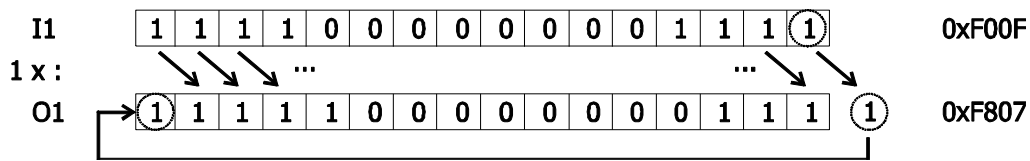

6.11.9 [220] Output one bit

	Type	Function		Type	Function
I1	%	input value 1	O1	b	One bit of I1, selected via P1
I2	-	-	O2	b	inverted output
I3	b	Master Set	P1	i	Number of bit (0 ... 15)
I4	b	Master Reset	P2	-	-

Description:

A selected bit of input value 1 is output at output 1. The bit is selected via P1.

P1=0: The least significant bit (LSB) is selected,

P1=15: The most significant bit (MSB) is selected.

Master Set sets all bits of the output value (Output = 0xFFFF).

Master Reset deletes all bits of the output value (Output = 0x0000).

Example	P1	I1	O1	O2
1)	1: Bit 1	0xF00F	1	0
2)	4: Bit 4	0x00FF	1	0
3)	4: Bit 4	0xFF00	0	1

In example 2):

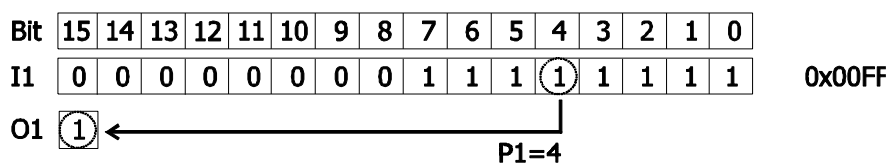

6.11.10 [221] Unite four bits to form a word

	Type	Function		Type	Function
I1	b	input value 1	O1	%	I1, I1, I3, I4 united to form a word
I2	b	input value 2	O2	%	inverted output
I3	b	input value 3	P1	i	Number of 1st bit (0 ... 15)
I4	b	input value 4	P2	-	-

Description:

The state of input 1 is copied to the bit of output O1 specified via P1, the state of input 2 to the next bit, etc. All other bits of the output value are zero. If P1 > 12, bits will be lost.

Master Set sets all bits of the output value (Output = 0xFFFF).

Master Reset deletes all bits of the output value (Output = 0x0000).

Example	P1	Copy	I4	I3	I2	I1	O1	O2
1)	0	I1 to bit 0 of O1, I2 to bit 1 of O1, I3 to bit 2 of O1, I4 to bit 3 of O1	1	0	1	0	0x000A	0xFFFF5
2)	5	I1 to bit 5 of O1, I2 to bit 6 of O1, I3 to bit 7 of O1, I4 to bit 8 of O1	1	0	1	0	0x0140	0xFE5BF
3)	14 (P1 > 12)	I1 to bit 14 of O1, I2 to bit 15 of O1, I3 not copied, I4 not copied	1	0	1	0	0x4000	0xBFFF

Re example 2):

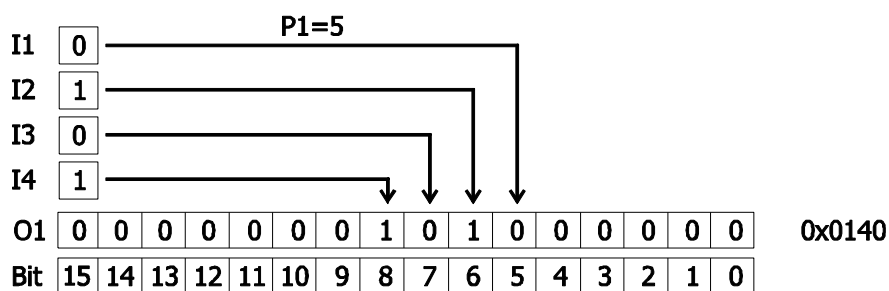

6.11.11 [222] Add two bits to a word

	Type	Function		Type	Function
I1	%	Input word 1	O1	%	O1=I1, Bit(P1)=I2, Bit(P2)=I3
I2	b	Input Bit 1	O2	%	inverted output
I3	b	Input Bit 2	P1	i	Number of 1st bit (0 ... 15)
I4	b	Master Reset	P2	i	Number of 2nd bit (0 ... 15)

Description:

The states at inputs I2 and I3 are inserted in certain bits of the input value 1. The bits are defined by P1 and P2.

- The input value at I1 is copied to output O1.
- The state of input I2 is copied to the bit of output O1 specified via P1.
- The state of input I3 is copied to the bit of output O1 specified via P2.

If a bit number outside of range 0 ... 15 is specified, the bit will not be written in the word.

Example

	P1	P2	Copy	I1	I2	I3	O1	O2
1)	12	11	I1 to O1, I2 to bit 12 of O1, I3 to Bit 11 of O1	0xF00F	0	1	0xE80F	0x17F0
2)	4	5	I1 to O1, I2 to bit 4 of O1, I3 to Bit 5 of O1	0xF00F	1	1	0xF03F	0x0FC0
3)	0	1	I1 to O1, I2 to bit 0 of O1, I3 to Bit 1 of O1	0xF00F	0	0	0xF00C	0x0FF3

Master Set sets all bits of the output value (Output = 0xFFFF).

Master Reset deletes all bits of the output value (Output = 0x0000).

In example 1):

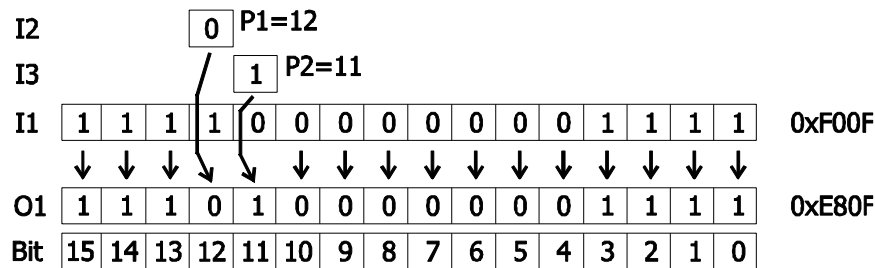

7 Examples of combinations in the function table

The examples describe combinations of signals of the device series ACU. The combination procedure is the same in the different device series. The names of the signal sources may be different.

7.1 Write index and read index

7.1.1 Write index and read index for FT-instructions

Via the write and read indices, the index of the instruction the parameters of which are to be read or written is specified. VTable uses the parameters automatically for writing and reading. The write and read parameters are required for parameterization via the keypad of a control unit or via a bus system (e.g. PROFIBUS).

Write index and read index for parameterization and reading of FT-instructions via software VPlus

The FT-instructions can be parameterized in the user interface VPlus or in the function table VTable. In the user interface VPlus, an index of the function table can be created via parameter *FT-Write Index (FT-Table Item)* **1341**. The chosen index corresponds to a column in the function table. The settings of parameters **1343** to **1351** are applied to the selected index of the function table. Via parameter *FT-Read Index (FT-Table Item)* **1342**, the values of a selected index can be read from the function table.

Parameters		Setting		
No.	Description	Min.	Max.	Fact. sett.
1341	FT write index (FT table item)	0	65	1
1342	FT read index (FT table item)	0	65	1

Settings for fixed parameterization
(non-volatile):

0: all instructions in EEPROM

1 ... 32: individual instructions in EEPROM

Settings for non-fixed parameterization
(volatile):

33: all instructions in RAM

34 ... 65: individual instructions in RAM



The settings "0" or "33" for *FT Write Index (FT table Item)* **1341** change all indices of a parameter in the EEPROM or RAM.

In the case of non-volatile storage (0..32), the changed values are still available when power supply is switched on again.

In the case of volatile storage (33...65), the data is only stored in RAM. If the unit is switched off, this data is lost and the data required are loaded from EEPROM.



CAUTION

Writing of the EEPROM is restricted to approx. 1 million times. If this number is exceeded, the device may be damaged.

Definition:

Instruction RAM = instruction EEPROM + 33

Write index and read index for FT-instructions in function table for parameters:

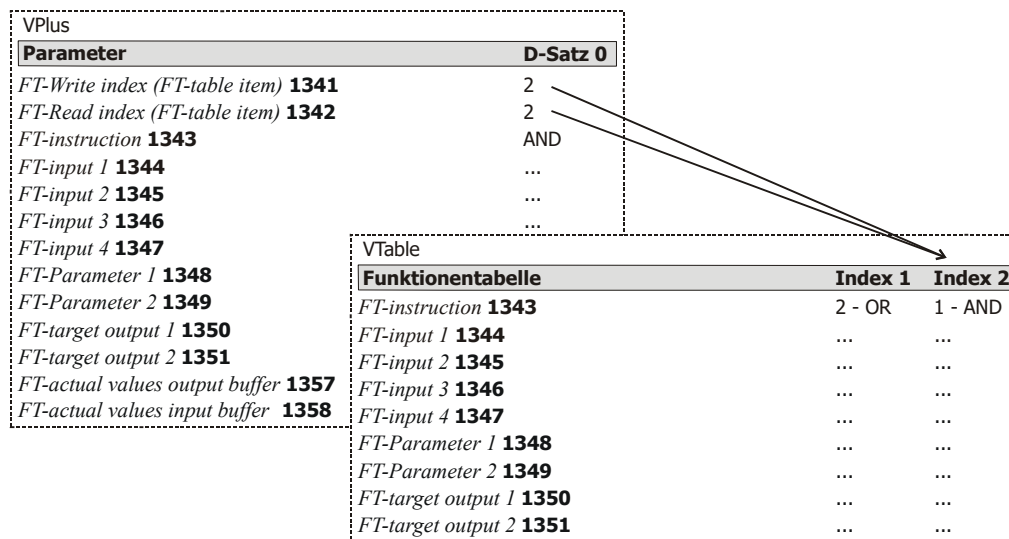

7.1.2 Write index and read index for the digital input buffer

Via the write and read indices, the index of the "Function table: input buffer" to be read or written is specified.

Write index and read index for parameterization and reading of "Function table: input buffer via software VPlus

The "Function table: input buffer" can be parameterized in the user interface VPlus or in the function table VTable. In the user interface VPlus, an index of the input buffer can be created via parameter *FT-Write Index (FT Input Buffer)* **1360**. The chosen index corresponds to a column in the "Function table: Input buffer" and thus an index of parameter *FT-Input Buffer* **1362**. The setting (selection of signal source or digital input) of parameter *FT-Input Buffer* **1362** is applied to the set index of "Function table: input buffer". Via parameter *FT-Read Index (FT-Input Buffer)* **1361**, the values of a selected index can be read from the "Function table: input buffer".

Parameters		Setting		
No.	Description	Min.	Max.	Fact. sett.
1360	FT-Write Index (FT-input buffer)	0	33	1
1361	FT-Read Index (FT-input buffer)	0	33	1

Settings for fixed parameterization (non-volatile):
 0: all input buffers in EEPROM
 1 ... 16: individual input buffer in EEPROM

Settings for non-fixed parameterization (volatile):
 17: all input buffers in RAM
 18 ... 33: individual input buffer in RAM



The settings "0" or "17" for *FT Write Index (FT input buffer)* **1360** change all values of an input buffer in the EEPROM or RAM.

In the case of non-volatile storage (0..16), the changed values are still available when power supply is switched on again.

In the case of volatile storage (17...33), the data is only stored in RAM. If the unit is switched off, this data is lost and the data required are loaded from EEPROM.

CAUTION



Writing of the EEPROM is restricted to approx. 1 million times. If this number is exceeded, the device may be damaged.

Definition:

Input buffer RAM = input buffer EEPROM +17

Write index and read index for the digital input buffer, example

VPlus	
Parameter	Data set 0
<i>FT-write index (FT-input buffer)</i> 1360	3
<i>FT-read index (FT-input buffer)</i> 1361	3
<i>FT-input buffer</i> 1362	75 - S6IND

VTable			
Function Table: input buffer	Index 1	Index 2	Index 3
<i>FT-input buffer</i> 1362	70 - Inverter Release	71 - S2IND	75 - S6IND

Diagram description: Arrows point from the 'Data set 0' values in the VPlus table to the corresponding 'Index' columns in the VTable. Specifically, the value '3' for parameter 1360 points to 'Index 3', and the value '75 - S6IND' for parameter 1362 points to 'Index 3'.

7.1.3 Write index and read index for the analog input buffer and FT fixed values

Via the write and read indices, the index of the "Input buffer analog" table the parameters of which are to be read or written is specified. VTable uses the parameters automatically for writing and reading. The write and read parameters are required for parameterization via the keypad of a control unit or via a bus system (e.g. PROFIBUS).

Write index and read index for parameterization and reading of "Input buffer analog" table via software VPlus

The "Input buffer analog" table can be parameterized in the user interface VPlus or in the function table VTable. In the user interface VPlus, an index of the "Input buffer analog" table can be created via parameter *FT-Write Index (FT Input analog)* **1377**. The chosen index corresponds to a column in the "Input buffer analog" table. The settings of parameters **1379** to **1397** are applied to the selected index of the "Input buffer analog" table. Via parameter *FT-Read Index (FT-Input analog)* **1378**, the values of a selected index can be read from the "Input buffer analog" table.

Parameters		Setting		
No.	Description	Min.	Max.	Fact. sett.
1377	FT-Write Index (FT-input analog)	0	9	1
1378	FT-Read Index (FT-input analog)	0	9	1

Settings for fixed parameterization (non-volatile):

0: all input buffers in EEPROM

1 ... 4: individual input buffer in EEPROM

Settings for non-fixed parameterization (volatile):

5: all input buffers in RAM

6 ... 9: individual input buffer in RAM



The settings "0" or "5" for *FT Write Index (FT input analog)* **1377** change all values of an input buffer in the EEPROM or RAM.

In the case of non-volatile storage (0..4), the changed values are still available when power supply is switched on again.

In the case of volatile storage (5..9), the data is only stored in RAM. If the unit is switched off, this data is lost and the data required are loaded from EEPROM.

CAUTION



Writing of the EEPROM is restricted to approx. 1 million times. If this number is exceeded, the device may be damaged.

Definition:

Input buffer RAM = input buffer EEPROM + 5

Write index and read index for the "Input buffer analog" table

VPlus		Data set 0	
Parameter			
<i>FT-write index (FT-input analog)</i> 1377		2	
<i>FT-read index (FT-input analog)</i> 1378		2	
<i>FT-input buffer frequency</i> 1379		62 - Reference Frequency Channel	
<i>FT-input buffer current</i> 1380		126 - Active Current	
.		...	
.		...	
.		...	

VTable		
Input buffer analog	Index 1	Index 2
<i>FT-input buffer frequency</i> 1379	9 - Zero	62 - Reference Frequency Channel
<i>FT-input buffer current</i> 1380	9 - Zero	126 - Active Current
.
.
.

7.2 Run/Stop

By default (factory setting) the function table is stopped and must be started by parameter *FT-RunMode* **1399**. In stop mode, no instructions are processed and there is no writing of the output buffer.



Instructions can only be edited in stop mode. If you try to make any changes while the function table is not in stop mode, an error will be displayed in VPlus. The attempted change will not be applied.

Further operation modes are available for processing individual instructions and instruction blocks. If an operation mode 11, 12, 21, 22, 31 or 32 is selected, the instruction block¹ will be processed according to the function described. Then, Run mode will be set to "0-Stop" automatically. In order to process another instruction block, the operation mode must be set to the corresponding value again.

<i>FT-Runmode</i> 1399	Function
0 - Stop	The function table is stopped and no longer processed.
1 - Run	The function table starts at index 1 and is processed normally.
2 - Continue	The function table is continued at the index where the processing was stopped last time, and the table is then processed normally.
11 - Single Step 12 - Single Step	One instruction is processed.
21 - Single Part 22 - Single Part	All instructions are processed until next writing of output buffer.
31 - Single Cycle 32 - Single Cycle	All instructions are processed until return jump. The return jump is reached when the maximum number of logic functions is processed or the next <i>FT-Instruction</i> 1343 = 0.



Two modes are available for an instruction block (1x, 2x, 3x).

For control of a **PLC** it is sufficient to select a mode and set it accordingly. When the instruction block was processed, the frequency inverter resets the operation mode to "0-Stop" automatically. The same mode can be selected again.



If a diagnosis via **VPlus** is to be performed, both modes are required. Execution of the instruction block must be started by the modes alternately, because VPlus only updates parameters (on ACU) which have been changed.



If "Single Step", "Single Part" or "Single Cycle" are selected, the selected mode is maintained. The status of the function table is shown exactly in *FT-Actual Values Function* **1356**.

7.2.1 Example Run/Stop

The following diagram shows a function block circuit which includes two jump functions (J1 and J2). Depending on the settings of parameter *FT-RunMode* **1399**, the procedure is as follows:

FT-Runmode **1399** = "1 – Run"

The sequence is processed continuously. Jump functions are processed according to input statuses.

¹In this connection, an instruction block may also include a single instruction.

FT-Runmode 1399 = "11 – Single Step", "12 – Single Step"

The sequence is interrupted after each instruction. Each time, the sequence is stopped, FT-RunMode **1399** must be restarted with "11 – Single Step" or "12 – Single Step". Jump functions are processed according to input statuses. Thus, the sequence is "I=1, Stop"; "I=2, Stop";...

FT-Runmode 1399 = "21 – Single Part", "22 – Single Part"

The sequence is processed until a jump instruction is reached which writes the output buffer. In this example, the buffer is written by both jump instructions. Thus, the sequence is "Block A, Stop"; "Block B, Stop";...

FT-Runmode 1399 = "31 – Single Cycle", "32 – Single Cycle"

The sequence is processed until the end is reached and the return jump to the start is effected (to block C). It may happen that Block B is processed repeatedly depending on the digital signals if the jump at J2 jumps to the beginning of Block B. A cycle may be, for example: "Block A, Block B, Block B, Block B, Block C, return jump, stop".

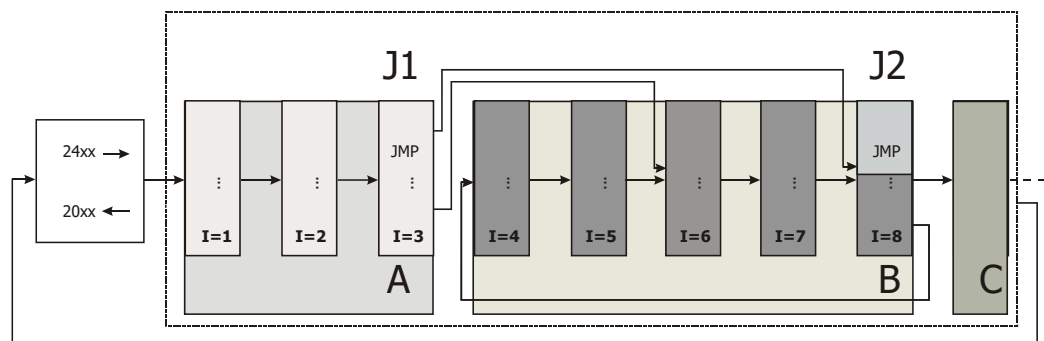

7.3 Example 1: Combining two digital outputs

Digital signals S2IND and S4IND are to control digital output S1OUT. If both signals are present, the output is TRUE. If not, the output is FALSE.

Settings in index 1 of function table:

FT Instruction 1343 = "1 - AND",

FT input 1 1344 = "2002 - FT input buffer 2",

FT input 2 1345 = "2004 - FT input buffer 4",

FT input 3 1346 = "6 - TRUE",

FT input 4 1347 = "6 - TRUE",

FT target output 1 1350 = "2401 - FT output buffer 1".

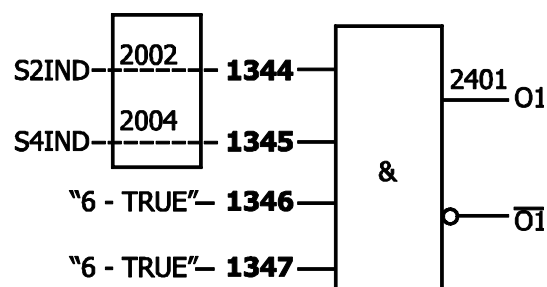

Settings in parameter group digital outputs:

Op. Mode Digital Output 1 530 = "80 - FT-Output Buffer 1".

7.4 Example 2: Combining several FT-instructions



The FT-instructions will be processed column by column according to the index in the table.

When designing application-specific logic links, in particular in the case of time-critical applications:

- Make sure to follow the correct order of the FT-instructions.
- Note the processing time (1 ms per FT-instruction).

Example of parameterization of instructions in a function table:

Step 1: Task

The drive may only start if both start signals (Start 1 and Start 2) are present and no error is present.

As soon as one of the two start signals (either Start 1 or Start 2) is no longer set, the drive is to be stopped.

If one of three error messages (error 1, error 2 or error 3) is present, the drive is to be stopped.

The acknow. input (Ack) is used for acknowledging the error messages.

Any error condition that may be present is to be signaled on digital output 1.

Step 2: Logic plan

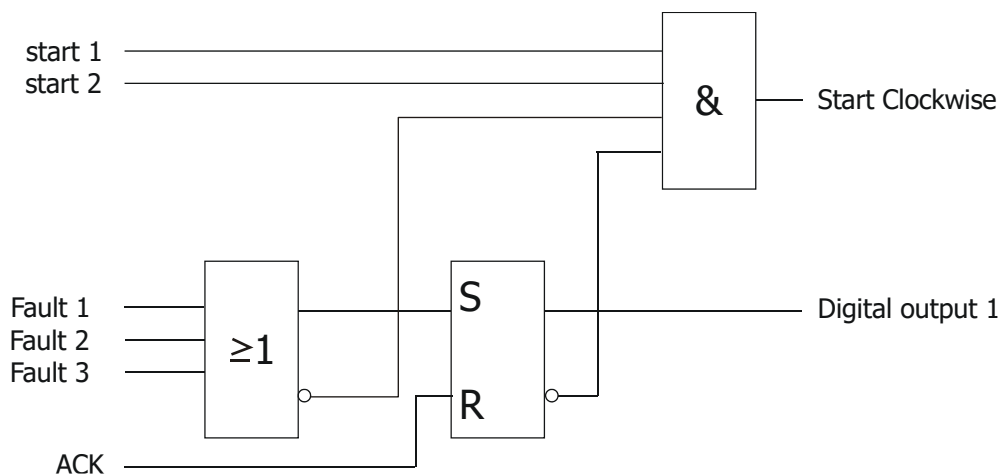

Step 3: Combinations with and making entries in function table VTable

Combine FT-instruction outputs to FT-instruction inputs in function table VTable.

Make FT-instruction outputs generally (globally) available via signal sources "2401 - FT-Output buffer 1" to "2416 FT-Output buffer 16" and combine them with other functions (no FT-instructions)

Output signals of FT-instructions via a digital output.

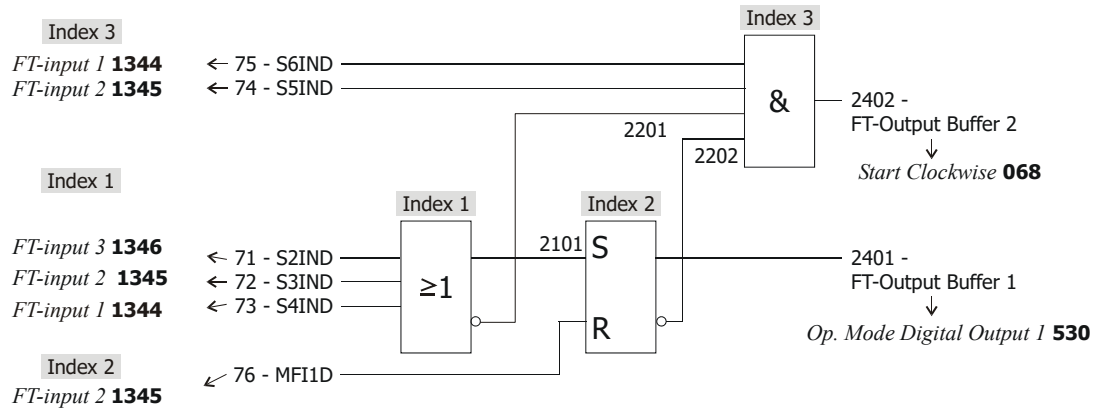

VTable

Function table input buffer	Index 2	Index 3	Index 4	Index 5	Index 6	Index 9
FT-input buffer 1362	71 - S2IND	72 - S3IND	73 - S4IND	74 - S5IND	75 - S6IND	76 - MF1D

Function table	Index 1	Index 2	Index 3
FT-instruction 1343	2 - OR	10 - RS-Flip-Flop	1 - AND
FT-input 1 1344	2004	2101	2006
FT-input 2 1345	2003	2009	2005
FT-input 3 1346	2002		2201
FT-input 4 1347			2202
FT-output 1 1350		2402	2401
FT-output 2 1351			

VPlus

Start Clockwise 068 = 2402 - FT-Output Buffer 2
Op. Mode Digital Output 1 530 = 80 - FT-Output Buffer 1

Table of functions	Index 1	Index 2	Index 3	Index 4
<i>FT instruction</i> 1343	2 - OR	10 - RS Flip-Flop Superior	1 - AND	0 - Off (last table item)
<i>FT input 1</i> 1344	2004 - FT input buffer 4	2101 - Outp.1 instruction 1	2006 - FT input buffer 6	7 - FALSE
<i>FT input 2</i> 1345	2003 - FT input buffer 3	2009 - FT input buffer 9	2005 - FT input buffer 5	7 - FALSE
<i>FT input 3</i> 1346	2002 - FT input buffer 2	7 - FALSE	2201 - Outp.1 instruction 1 ²	7 - FALSE
<i>FT input 4</i> 1347	7 - FALSE	7 - FALSE	2202 - Outp.1 instruction 2 ³	7 - FALSE
<i>FT-Target Output 1</i> 1350	0 - Output not usable globally	2402 - FT-Output buffer 2	2401 - FT-Output buffer 1	0 - Output not usable globally
<i>FT-Target Output 2</i> 1351	0 - Output not usable globally	0 - Output not usable globally	0 - Output not usable globally	0 - Output not usable globally

The outputs of the FT-instructions are available as sources and can be linked to the inputs of other functions or outputs via digital outputs.

Example:

- Linking of AND function output with Start Clockwise Function, parameter *Start clockwise* **068** = "2402 - FT output buffer 2"
- Linking of RS-Flip-Flop output with digital output 1; Parameter *Operation mode digital output 1* **530** = "80 - FT-Output buffer 1"

² Inverted output of function 1 (in this example of OR function)

³ Inverted output of function 2 (in this example of RX-Flip-Flop)

7.5 Example 3: Parameterization of logic diagram

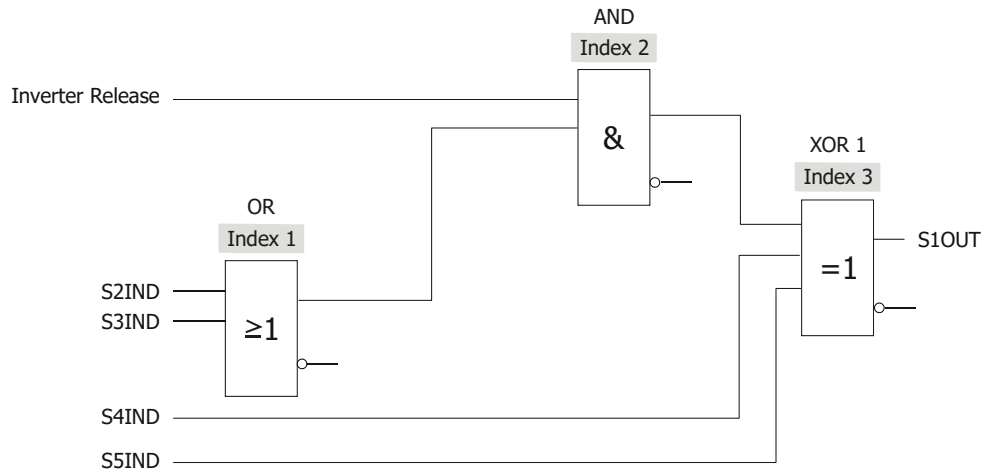

VTable

Function Table: Input Buffer	Index 1	Index 2	Index 3	Index 4	Index 5
<i>FT-input buffer</i> 1362	70 - Inverter Release	71 - S2IND	72 - S3IND	73 - S4IND	74 - S5IND

Function Table	Index 1	Index 2	Index 3
<i>FT-instruction</i> 1343	2 - OR	1 - AND	3 - XOR 1
<i>FT-input 1</i> 1344	2002	2001	2102
<i>FT-input 2</i> 1345	2003	2101	2004
<i>FT-input 3</i> 1346			2005
<i>FT-input 4</i> 1347			
<i>FT-output 1</i> 1350			2401
<i>FT-output 1</i> 1351			

VPlus

<i>Op. Mode Digital Output 1</i> 530 = 80 - FT-Output Buffer 1

8 Actual values, output signals and messages

8.1 Actual values of digital functions

Actual values of input and output buffers

- The actual values of the global outputs 2401 to 2416 - "PLC output buffer" are indicated by parameter *PLC actual values output buffer* **1357**.
- The actual values of the global inputs 2001 to 2016 - "PLC input buffer" are indicated by parameter *PLC actual values input buffer* **1358**.

Example

e.g. display:

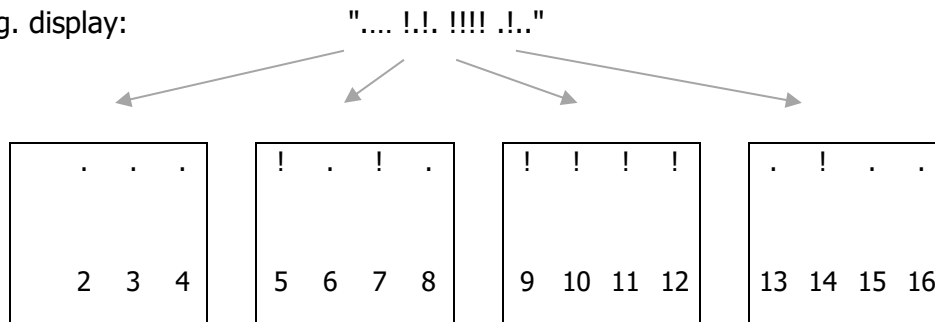

"," = FALSE

!" = TRUE

In the example, the following is TRUE:

- 2405 - PLC output buffer 5
- 2407 - PLC output buffer 7
- 2409 - PLC output buffer 9
- 2410 - PLC output buffer 10
- 2411 - PLC output buffer 11
- 2412 - PLC output buffer 12
- 2414 - PLC output buffer 14

Actual values of digital instructions

The actual values of an instruction are indicated by parameter *PLC Actual values function* **1356**.

From left to right, the following is displayed:

- state of PLC or function table (e.g. started, stopped)
- Index number of selected instruction via *PLC read index (PLC input buffer)* **1361**
- Inputs of selected instruction
- Outputs of selected instruction
- Index number of last processed instruction
- Inputs of last processed instruction
- Outputs of last processed instruction

The states of the function table are:

R: Running – function table or PLC started

S: Stopped – function table or PLC stopped

U: Updating – input and output buffer are being updated

E: Empty – function table or PLC is empty

I: Initialization

Example

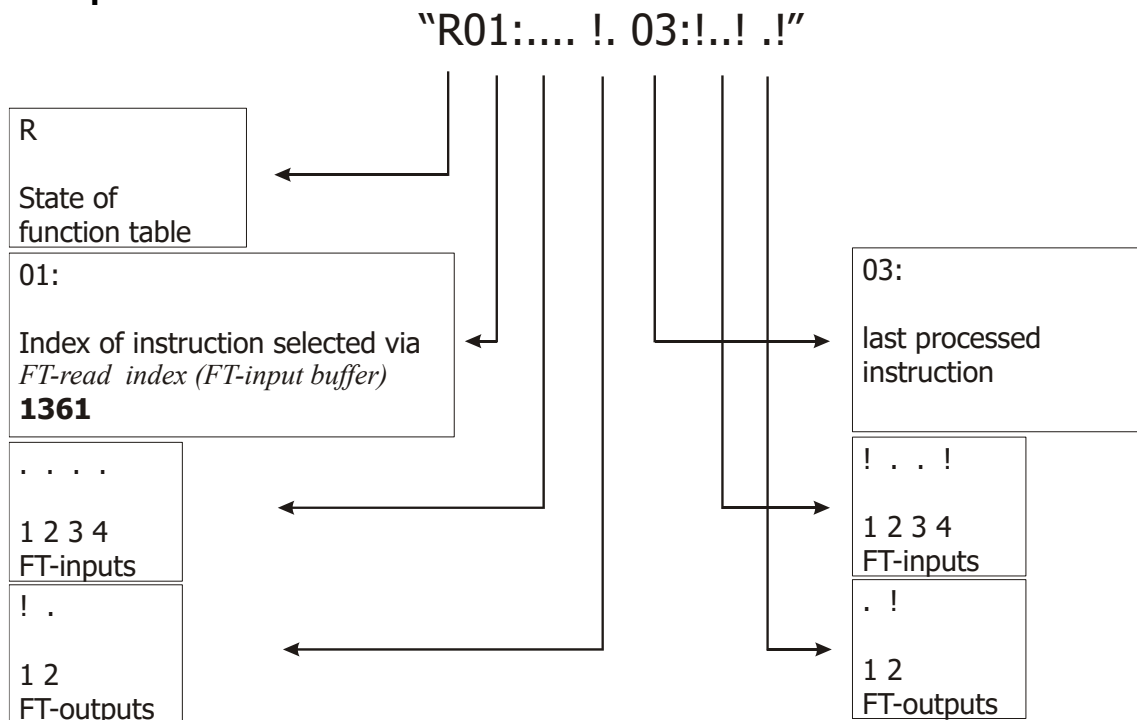

"." = FALSE

"!" = TRUE



For information on other actual values, refer to the operating instructions of the frequency inverter.

8.2 Actual values of analog functions

The following parameters indicate the actual values

- of the four indices of the analog input buffer.
- of the four signal sources of the analog output buffer (in the case of parameterization using the function table, the signal sources assigned to parameters *PLC target output 1* **1350** or *PLC target output 2* **1351**).

Parameters	No.	Parameters	No.
PLC actual frequency value from P.1379	1400	PLC actual output current value 251x	1407
PLC actual current value from P.1380	1401	PLC actual output percentage 252x	1408
PLC actual percentage from P.1381	1402	PLC actual output voltage eff. 253x	1409
PLC actual voltage eff. from P.1382	1403	PLC actual output voltage sp. 253x	1410
PLC actual voltage sp. from P.1382	1404	PLC actual output general 255x	1411
PLC actual value general from P.1383	1405	PLC actual value flag 256x	1412
PLC actual output frequency 250x	1406		

Example: Actual value display, parameterization using the function table

Vtable	
Function Table Input Buffer analog	Index 2
<i>FT-input buffer frequency</i> 1379	10 - Stator Frequency
Function Table	Index 1
<i>FT-target output 1</i> 1350	[2504 - FT-Output Frequency 4]

VPlus				
Parameter				
<i>FT-Act. Val. Freq. from P.1379</i> 1400	0.00 Hz	15.00 Hz	0.00 Hz	0.00 Hz
<i>FT-Act. Val. Outp. Freq. 250x</i> 1406	0.00 Hz	0.00 Hz	0.00 Hz	5.00 Hz

The parameter names may differ from the names shown, depending on the device series. The parameter numbers are identical:

8.3 Signals for digital outputs of device

The following output signals of the can be assigned to the digital outputs of the frequency inverter.

Operation mode	Function
0 - Off	Digital output is switched off
80 - PLC output buffer 1	Digital output signal of an instruction. Signal source "2401 - PLC output buffer 1" is the output signal. This signal source contains the output value of the instruction assigned to signal source 2401.
81 - PLC output buffer 2	Digital output signal of an instruction. Signal source "2402 - PLC output buffer 2" is the output signal. This signal source contains the output value of the instruction assigned to signal source 2402.
82 - PLC output buffer 3	Digital output signal of an instruction. Signal source "2403 - PLC output buffer 3" is the output signal. This signal source contains the output value of the instruction assigned to signal source 2403.
83 - PLC output buffer 4	Digital output signal of an instruction. Signal source "2404 - PLC output buffer 4" is the output signal. This signal source contains the output value of the instruction assigned to signal source 2404.
100 to 183	Operation modes inverted (LOW active).

8.4 Signals for analog outputs of device

Via a multifunction output, the values of analog instructions can be output.

The following output signals of the function table can be assigned to the analog outputs.

Operation mode		Function
61 -	Abs. value PLC outp. percent 1	Analog output signal of an instruction as an absolute value. Signal source "2521 - PLC output percent 1" is the output signal. This signal source contains the output value of the instruction assigned to signal source 2521.
62 -	Abs. value PLC outp. percent 2	Analog output signal of an instruction as an absolute value. Signal source "2522 - PLC output percent 2" is the output signal. This signal source contains the output value of the instruction assigned to signal source 2522.
161 -	PLC outp. percent 1	Analog output signal of an instruction. Signal source "2521 - PLC output percent 1" is the output signal. This signal source contains the output value of the instruction assigned to signal source 2521.
162 -	PLC outp. percent 2	Analog output signal of an instruction. Signal source "2522 - PLC output percent 2" is the output signal. This signal source contains the output value of the instruction assigned to signal source 2522.

8.5 Signal sources for device function

Signal sources of the instructions can be assigned to the device functions for further processing. The values are updated when the output buffer is written.

Signal source
Digital
2401 ... 2416 - PLC output buffer 1 ... 16
Analog
2501 ... 2504 - PLC outp. frequency 1 ... 4
2511 ... 2514 - PLC outp. current 1 ... 4
2521 ... 2524 - PLC outp. percent 1 ... 4
2531 ... 2534 - PLC outp. voltage 1 ... 4
2551 ... 2554 - PLC outp. user 1 ... 4
2561 ... 2564 - PLC flag 1 ... 4

8.6 Error messages of instruction "95 - Triggering an error"

Error	Description
F3031	User error 1. In instruction "95 - Triggering of an error" shut-down behavior P1 was triggered via input I1.
F3032	User error 2. In instruction "95 - Triggering of an error" shut-down behavior P1 was triggered via input I2.
F3033	User error 3. In instruction "95 - Triggering of an error" shut-down behavior P1 was triggered via input I3.
F3034	User error 4. In instruction "95 - Triggering of an error" shut-down behavior P1 was triggered via input I4.

9 Operation as state machine

In the previous chapters, the PLC functions were introduced as a sequence of various instructions. In addition, a state machine sequence (also referred to as finite state machine) can be integrated by the specified instruction types. A state machine is often used for representing sequences schematically and for easier implementation of solutions.

In order to realize a state machine sequence, the jump functions are of particular importance. The jump functions are required for changing the state. Inputs 1 and 2 of the jump function are used for checking the condition for the transition. Inputs 3 and 4 set the input buffer and write the output buffer. In the state machine, inputs 3 and 4 are generally set to TRUE at the jump functions for this reason in order to update the changing signals for changing the state.

9.1 Example of a controller

Example:

A lifting gear with two positions ("up" and "down") is to be controlled by the function table. The target position is defined via a toggle switch. Each position is equipped with an initiator which informs the frequency inverter that the target has been reached. As soon as the position is reached, the frequency inverter is to stop and the respective LED "top" or "bottom" is to be switched on. As soon as the drive starts again, the LED is turned off.

Both positions are provided with a door which can be opened manually by the user. As soon as one of the two doors is open, the warning lamp "top" or "bottom" is pulsed on and off at an interval of 100 ms. Note that the "door open" signals from the two doors are connected in series.

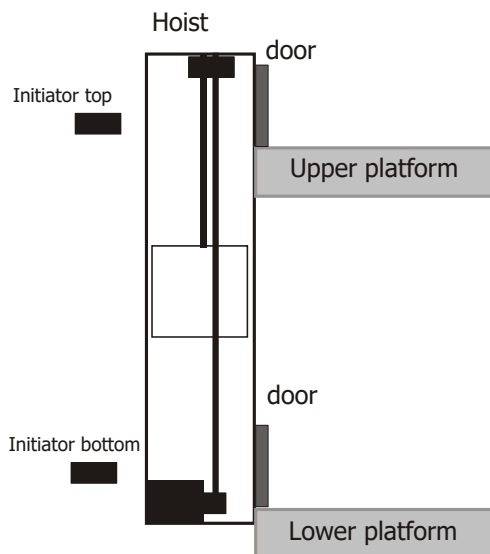

Representation as state machine step 1

The requirements described above are shown in the following diagram as a state machine. It must be considered that the state must be initialized first when the inverter is switched on (or in the case of a reset). In this example, initialization is performed in order to switch to the correct state. First, the initiators are evaluated. If one of the initiators signals that the position has been reached, the corresponding state is activated. If no initiator signal is present, the lower position is approached.

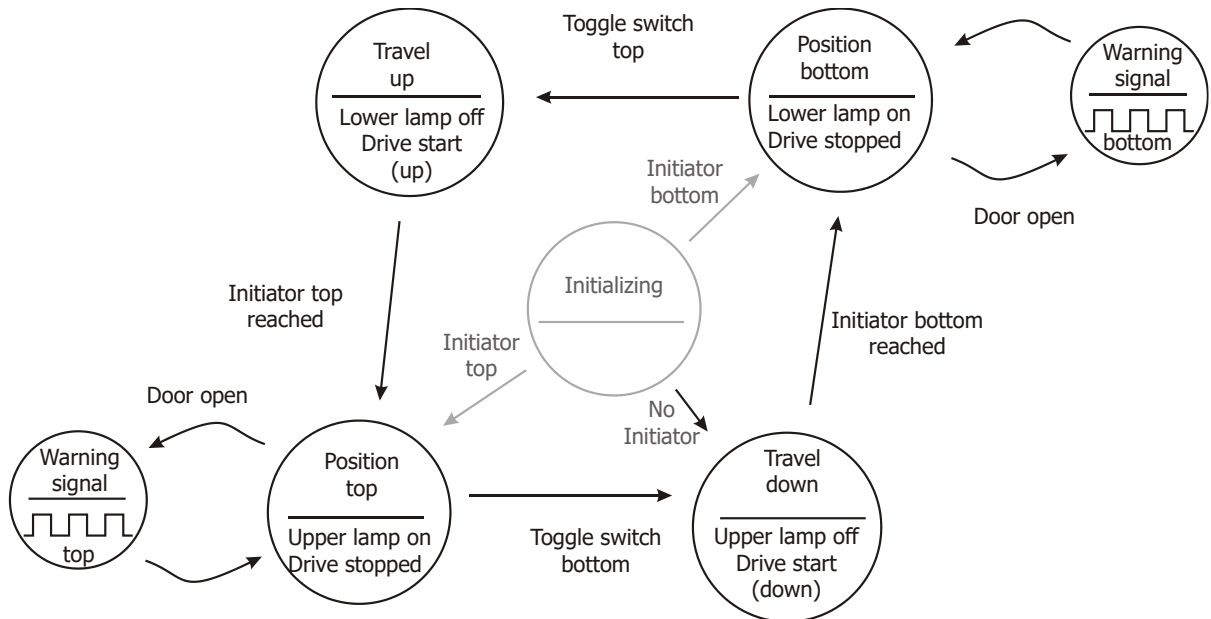

Representation as state machine step 2

The events and actions are assigned to the digital signals of the ACU. At first, the signals are linked to the input and output buffer. An EM-IO-03 extension module is available.

Function	ACU	Input buffer	Output buffer
toggle switch (top/bottom)	S5IND (1/0)	2005	
top position initiator (reached/not reached)	S4IND (1/0)	2004	
bottom position initiator (reached/not reached)	S2IND (1/0)	2002	
door open (open/closed)	S3IND (1/0)	2003	
bottom LED (on/off)	S1OUTD (1/0)		2401
top LED (on/off)	S3OUTD (1/0)		2402
bottom position door lamp (on/off)	MFO1D (1/0)		2403
top position door lamp (on/off)	EM-S1OUTD (1/0)		2404
start drive (up)	Start Clockwise 068		2410
start drive (down)	Start Anticlockwise 069		2411

With the assignment of the digital signals, the following diagram is obtained:

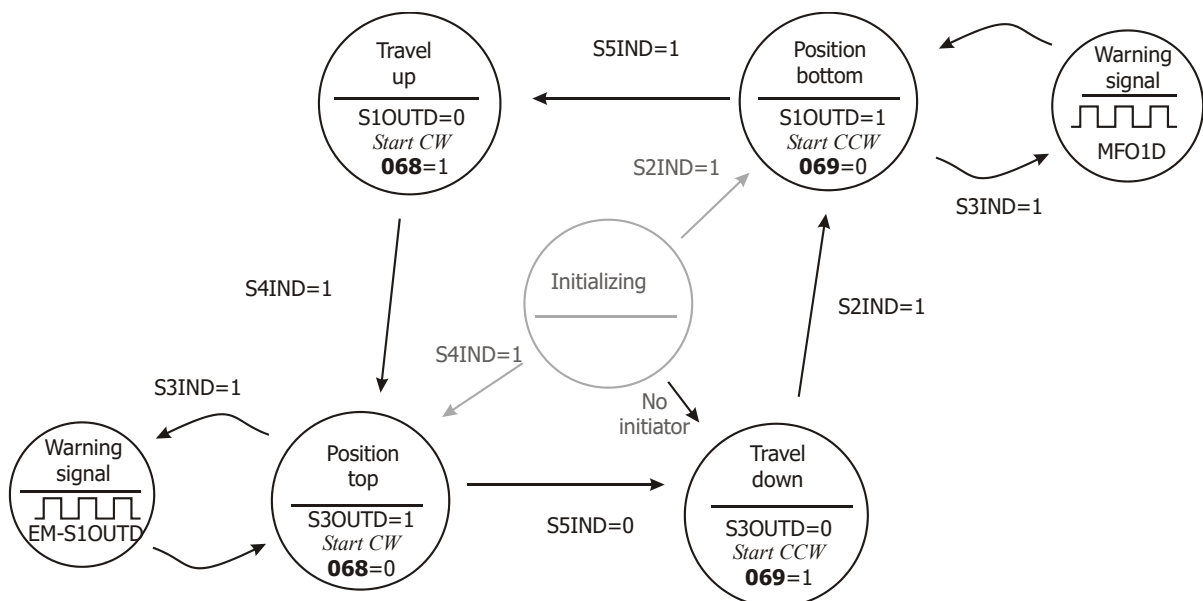

Solution:

For assignment of the ACU signals and the input buffer of the function table, the following parameterization is required:

2002: *FT-Input Buffer 1362*, Index 2 : "71 – S2IND"

2003: *FT-Input Buffer 1362*, Index 3 : "72 – S3IND"

2004: *FT-Input Buffer 1362*, Index 4 : "73 – S4IND"

2005: *FT-Input Buffer 1362*, Index 5 : "74 – S5IND"

2006: *FT-Input Buffer 1362*, Index 6 : "274 – S5IND inverted" (*)

(*): Parameterization deviating from factory settings.

For assignment of the ACU signals and the output buffer of the function table, the following parameterization is required:

<i>Operation mode digital output 1</i> 530	2401 - FT-Output buffer 1
<i>Operation mode digital output 3</i> 532	2402 - FT-Output buffer 2
<i>Op. Mode EM-SIOUTD</i> 533	2404 - FT-Output buffer 4
<i>MFO1: Operation mode</i> 550	1 - Digital output
<i>MFO1: Digital Operation</i> 554	2403 - FT-Output buffer 3
<i>Start Clockwise</i> 068	2410 - FT-Output buffer 10
<i>Start Anticlockwise</i> 069	2411 - FT-Output buffer 11

To enable easy checking of the transition "Top Position" → "Down", the inverted signal of signal S5IND in the input buffer is assigned. For easier parameterization, the names of the states used so far will be replaced by numerical values.

The following diagram is obtained for the signals of the function table:

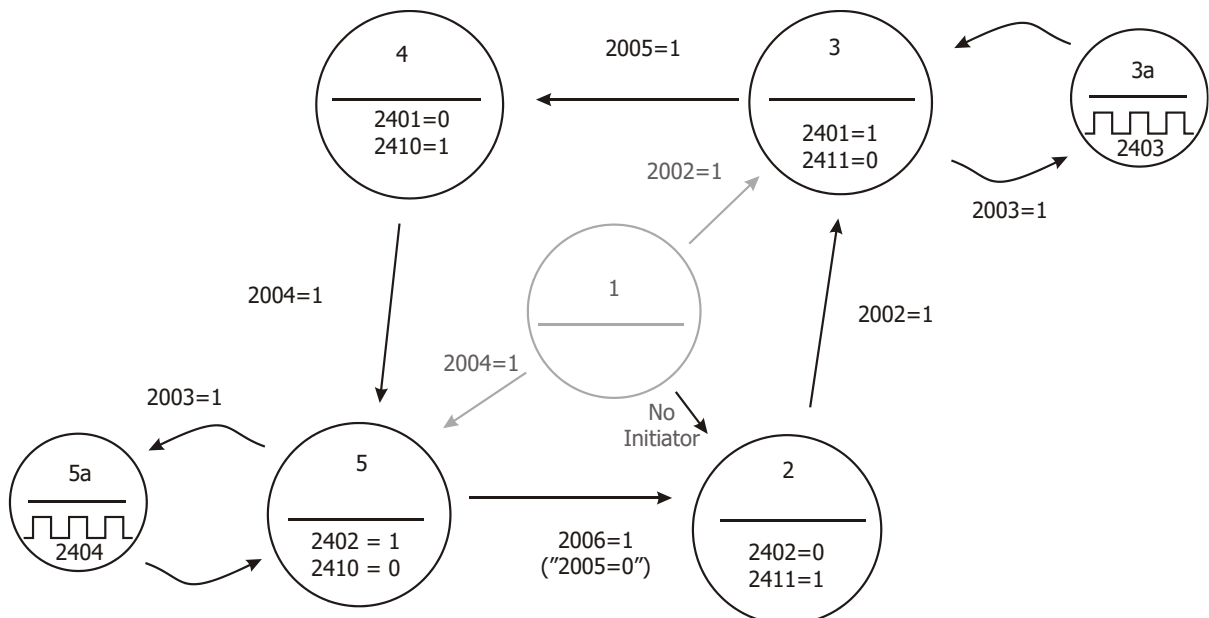

In the first step, the states and transitions are translated into instructions.

Setting state outputs:

The easiest way to set a digital signal (independent of one or several input signals) is using a Boolean operation. In this application, an OR instruction is used and an input is set to TRUE. In this way, *FT target output 1 1350* is set to TRUE (=1) and *FT target output 2 1351* is set to FALSE (=0).

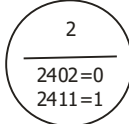
	<i>FT-Instruction 1343</i>	2 – OR
	<i>FT input 1 1344</i>	6 – TRUE
	<i>FT input 2 1345</i>	7 – FALSE
	<i>FT input 3 1346</i>	7 – FALSE
	→ <i>FT input 4 1347</i>	7 – FALSE
	<i>FT-Parameter 1 1348</i>	0
	<i>FT-Parameter 2 1349</i>	0
	<i>FT target output 1 1350</i>	2411 FT-Output buffer 11
<i>FT target output 2 1351</i>	2402 FT-Output buffer 2	

For states 3 to 5, instructions can be created in the same way.

Clock generator (state 3a)

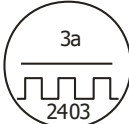
	<i>FT instruction 1343</i>	80 – Clock generator
	<i>FT input 1 1344</i>	2003 - Input buffer 3
	<i>FT input 2 1345</i>	7 – FALSE
	<i>FT input 3 1346</i>	7 – FALSE
	→ <i>FT input 4 1347</i>	7 – FALSE
	<i>FT-Parameter 1 1348</i>	100
	<i>FT-Parameter 2 1349</i>	100
	<i>FT-Target Output 1 1350</i>	0
<i>FT-Target Output 2 1351</i>	0	

The clock generator of state 5a is created in the same way as 3a.

Transition from state 2 to state 3

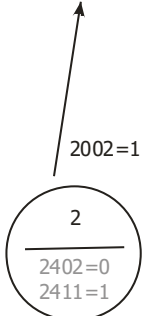
	<i>FT instruction 1343</i>	100 – Jump function
	<i>FT input 1 1344</i>	6 – TRUE
	<i>FT input 2 1345</i>	2002 - Input buffer 2
	<i>FT input 3 1346</i>	6 – TRUE
	→ <i>FT input 4 1347</i>	6 – TRUE
	<i>FT-Parameter 1 1348</i>	Index number _{Next state}
	<i>FT-Parameter 2 1349</i>	Index number _{Own state}
	<i>FT target output 1 1350</i>	0
<i>FT target output 2 1351</i>	0	

Items "Next state" and "Own state" are used as placeholders until the correct numbers of the indices can be entered. The transition from state 4 to state 5 can be performed in the same way.

Transition from state 3 to state 4

The transition from state 3 to state 4 requires a different method, as two jump events have to be checked.

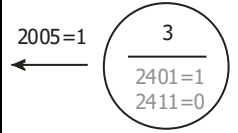
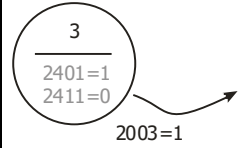
	<p><i>FT instruction</i> 1343</p> <p><i>FT input 1</i> 1344</p> <p><i>FT input 2</i> 1345</p> <p><i>FT input 3</i> 1346</p> <p>→ <i>FT input 4</i> 1347</p> <p><i>FT-Parameter 1</i> 1348</p> <p><i>FT-Parameter 2</i> 1349</p> <p><i>FT-Target Output 1</i> 1350</p> <p><i>FT-Target Output 2</i> 1351</p>	<p>100 – Jump function</p> <p>2005 - Input buffer 5</p> <p>6 – TRUE</p> <p>6 – TRUE</p> <p>6 – TRUE</p> <p>6 – TRUE</p> <p>next state</p> <p>No jump, next step</p> <p>0</p> <p>0</p>
	<p><i>FT instruction</i> 1343</p> <p><i>FT input 1</i> 1344</p> <p><i>FT input 2</i> 1345</p> <p><i>FT input 3</i> 1346</p> <p>→ <i>FT input 4</i> 1347</p> <p><i>FT-Parameter 1</i> 1348</p> <p><i>FT-Parameter 2</i> 1349</p> <p><i>FT-Target Output 1</i> 1350</p> <p><i>FT-Target Output 2</i> 1351</p>	<p>100 – Jump function</p> <p>6 – TRUE</p> <p>2003 - Input buffer 3</p> <p>6 – TRUE</p> <p>6 – TRUE</p> <p>6 – TRUE</p> <p>Jump target, clock generator</p> <p>Jump evaluation, own state</p> <p>0</p> <p>0</p>

Items "Next state" and "Jump target, clock generator", "Jump evaluation, own state" are used as placeholders until the correct numbers of the indices can be entered. Item "No jump, next step" is a placeholder for any value. The jump function is active only if "2005 – Input buffer 2005" = TRUE is fulfilled (DI5=0). Otherwise, the next step will be executed. The transition from state 5 to state 2 can be performed again in the same way.

Initialization

Initialization is a jump function with three targets. For this reason, 2 jump functions are required. The initialization must start with index 1 because the function table always starts at index 1 after a restart.

	<p>→</p> <p><i>FT instruction</i> 1343</p> <p><i>FT input 1</i> 1344</p> <p><i>FT input 2</i> 1345</p> <p><i>FT input 3</i> 1346</p> <p><i>FT input 4</i> 1347</p> <p><i>FT-Parameter 1</i> 1348</p> <p><i>FT-Parameter 2</i> 1349</p> <p><i>FT-Target Output 1</i> 1350</p> <p><i>FT-Target Output 2</i> 1351</p>	<p>100 – Jump function</p> <p>2004 - Input buffer 4</p> <p>6 – TRUE</p> <p>6 – TRUE</p> <p>6 – TRUE</p> <p>Jump target state 5</p> <p>No jump, next step</p> <p>0</p> <p>0</p>
	<p>→</p> <p><i>FT instruction</i> 1343</p> <p><i>FT input 1</i> 1344</p> <p><i>FT input 2</i> 1345</p> <p><i>FT input 3</i> 1346</p> <p><i>FT input 4</i> 1347</p> <p><i>FT-Parameter 1</i> 1348</p> <p><i>FT-Parameter 2</i> 1349</p> <p><i>FT-Target Output 1</i> 1350</p> <p><i>FT-Target Output 2</i> 1351</p>	<p>100 – Jump function</p> <p>6 – TRUE</p> <p>2002 - Input buffer 2</p> <p>6 – TRUE</p> <p>6 – TRUE</p> <p>Jump target state 3</p> <p>Jump target state 2</p> <p>0</p> <p>0</p>

Now, all blocks are defined. These blocks are entered into the table, the placeholders are replaced by indices. The states are marked in different colors. Non-relevant items are hidden.

	Index 1	Index 2
<i>FT instruction</i> 1343	100 – Jump function	100 – Jump function
<i>FT input 1</i> 1344	2004 - Input buffer 4	6 – TRUE
<i>FT input 2</i> 1345	6 – TRUE	2002 - Input buffer 2
<i>FT input 3</i> 1346	6 – TRUE	6 – TRUE
<i>FT input 4</i> 1347	6 – TRUE	6 – TRUE
<i>FT-Parameter 1</i> 1348	11	5
<i>FT-Parameter 2</i> 1349	2	3
<i>FT-Target Output 1</i> 1350	0	0
<i>FT-Target Output 2</i> 1351	0	0
<i>FT Commentary</i> 1352	Init 1	Init 2

	Index 3	Index 4
<i>FT instruction</i> 1343	2 – OR	100 – Jump function
<i>FT input 1</i> 1344	6 – TRUE	6 – TRUE
<i>FT input 2</i> 1345	7 – FALSE	2002 - Input buffer 2
<i>FT input 3</i> 1346	7 – FALSE	6 – TRUE
<i>FT input 4</i> 1347	7 – FALSE	6 – TRUE
<i>FT-Parameter 1</i> 1348	0	5
<i>FT-Parameter 2</i> 1349	0	4
<i>FT-Target Output 1</i> 1350	2411 FT-Output buffer 11	0
<i>FT-Target Output 2</i> 1351	2402 FT-Output buffer 2	0
<i>FT Commentary</i> 1352	Z2: 2411=1	Z2 --> Z3

	Index 5	Index 6
<i>FT instruction</i> 1343	2 – OR	80 – Clock generator
<i>FT input 1</i> 1344	6 – TRUE	2003 - Input buffer 3
<i>FT input 2</i> 1345	7 – FALSE	7 – FALSE
<i>FT input 3</i> 1346	7 – FALSE	7 – FALSE
<i>FT input 4</i> 1347	7 – FALSE	7 – FALSE
<i>FT-Parameter 1</i> 1348	0	100
<i>FT-Parameter 2</i> 1349	0	100
<i>FT-Target Output 1</i> 1350	2401 FT-Output buffer 1	2403 FT-Output buffer 3
<i>FT-Target Output 2</i> 1351	2411 FT-Output buffer 11	0
<i>FT Commentary</i> 1352	Z3: 2401=1	Z3a: clock

	Index 7	Index 8
<i>FT instruction</i> 1343	100 – Jump function	100 – Jump function
<i>FT input 1</i> 1344	2005 - Input buffer 5	6 – TRUE
<i>FT input 2</i> 1345	6 – TRUE	2003 - Input buffer 3
<i>FT input 3</i> 1346	6 – TRUE	6 – TRUE
<i>FT input 4</i> 1347	6 – TRUE	6 – TRUE
<i>FT-Parameter 1</i> 1348	9	6
<i>FT-Parameter 2</i> 1349	8	7
<i>FT-Target Output 1</i> 1350	0	0
<i>FT-Target Output 2</i> 1351	0	0
<i>FT Commentary</i> 1352	Z3 --> Z4	Z3 -> Z4



	Index 9	Index 10
<i>FT instruction</i> 1343	2 – OR	100 – Jump function
<i>FT input 1</i> 1344	6 – TRUE	6 – TRUE
<i>FT input 2</i> 1345	7 – FALSE	2002 - Input buffer 2
<i>FT input 3</i> 1346	7 – FALSE	6 – TRUE
<i>FT input 4</i> 1347	7 – FALSE	6 – TRUE
<i>FT-Parameter 1</i> 1348	0	11
<i>FT-Parameter 2</i> 1349	0	10
<i>FT-Target Output 1</i> 1350	2410 FT-Output buffer 10	0
<i>FT-Target Output 2</i> 1351	2401 FT-Output buffer 1	0
<i>FT Commentary</i> 1352	Z4: 2410=1	Z4 --> Z5

	Index 11	Index 12
<i>FT instruction</i> 1343	2 – OR	80 – Clock generator
<i>FT input 1</i> 1344	6 – TRUE	2003 - Input buffer 3
<i>FT input 2</i> 1345	7 – FALSE	7 – FALSE
<i>FT input 3</i> 1346	7 – FALSE	7 – FALSE
<i>FT input 4</i> 1347	7 – FALSE	7 – FALSE
<i>FT-Parameter 1</i> 1348	0	100
<i>FT-Parameter 2</i> 1349	0	100
<i>FT-Target Output 1</i> 1350	2401 FT-Output buffer 1	2404 FT-Output buffer 4
<i>FT-Target Output 2</i> 1351	2411 FT-Output buffer 11	0
<i>FT Commentary</i> 1352	Z5: 2401=1	Z5a: clock

	Index 13	Index 14
<i>FT instruction</i> 1343	100 – Jump function	100 – Jump function
<i>FT input 1</i> 1344	2006 - Input buffer 6	6 – TRUE
<i>FT input 2</i> 1345	6 – TRUE	2003 - Input buffer 3
<i>FT input 3</i> 1346	6 – TRUE	6 – TRUE
<i>FT input 4</i> 1347	6 – TRUE	6 – TRUE
<i>FT-Parameter 1</i> 1348	3	12
<i>FT-Parameter 2</i> 1349	14	13
<i>FT-Target Output 1</i> 1350	0	0
<i>FT-Target Output 2</i> 1351	0	0
<i>FT Commentary</i> 1352	Z5 --> Z2	Z5 -> Z2

10 List of parameters

The parameter list is structured according to the menu branches of the control unit. The parameters are listed in ascending numerical order. A headline (shaded) can appear several times, i.e. a subject area may be listed at different places in the list. For better clarity, the parameters have been marked with pictograms:

-  The parameter is available in the four data sets.
- The parameter value is set by the SETUP routine.
- This parameter cannot be written when the frequency inverter is in operation.
-  This parameter can only be written in setting *FT-Runmode* **1399** = "0 - Stop".

I_{FUN} , U_{FUN} , P_{FUN} : Nominal values of frequency inverter, \ddot{u} : Overload capacity of frequency inverter













In the KP500 control unit, parameter numbers > 999 are represented in hexadecimal form (999, A00 ... B54 ... C66 ...).

10.1 Actual values

Table of functions				
No.	Description	Unit	Display range	Chapter
1356	PLC actual values function	-	X01:... .. 01:... ..to X32:!!!! !! 32:!!!! !!	8.1
1357	PLC actual values output buffer	- to !!!! !!!! !!!! !!!!	8.1
1358	PLC Actual values input buffer	- to !!!! !!!! !!!! !!!!	8.1
1400	PLC actual frequency value from P.1379	Hz	0.00 ... 999.99	8.2
1401	PLC actual current value from P.1380	A	0.0 ... I_{max}	8.2
1402	PLC actual percentage from P.1381	%	-200 ... 200	8.2
1403	PLC actual voltage eff. from P.1382	V	0.0 ... U_{FUN}	8.2
1404	PLC actual voltage sp. from P.1382	V	0.0 ... U_{FUN}	8.2
1405	PLC actual value general from P.1383	-	-32767 ... 32767	8.2
1406	PLC actual output frequency 250x	Hz	-999.99 ... 999.99	8.2
1407	PLC actual output current value 251x	A	$-I_{max}$... I_{max}	8.2
1408	PLC actual output percentage 252x	%	-200 ... 200	8.2
1409	PLC actual output voltage eff. 253x	V	0.0 ... U_{FUN}	8.2
1410	PLC actual output voltage sp. 253x	V	0.0 ... U_{FUN}	8.2
1411	PLC actual output general 255x	-	-32767 ... 32767	8.2
1412	PLC actual value flag 256x	%	-327.67 ... 327.67	8.2

10.2 Parameters of function table

The following parameters are needed only for parameterization using the function table.

PLC functions					
No.	Description	Unit	Setting range	Factory setting	Chapter
1341	PLC write index (PLC table item)	-	0 ... 65	1	7.1.1
1342	PLC read index (PLC table item)	-	0 ... 65	1	7.1.1
 1343	PLC instruction	-	Selection	0 - Off (last table item)	7.3
 1344	PLC input 1	-	Selection	7 - FALSE	7.3
 1345	PLC input 2	-	Selection	7 - FALSE	7.3
 1346	PLC input 3	-	Selection	7 - FALSE	7.3
 1347	PLC input 4	-	Selection	7 - FALSE	7.3
 1348	PLC parameter 1	*) ⁴	0 ... 65535	10	5.2, 6.1
 1349	PLC parameter 2		0 ... 65535	10	5.2, 6.1
 1350	SPS target output 1	-	Selection	0 - Output not usable globally	7.3
 1351	SPS target output 2	-	Selection	0 - Output not usable globally	7.3
1352	PLC commentary	-	16 characters	-	7.3
PLC functions input buffer					
1360	PLC write index (PLC table item)	-	0 ... 33	1	7.1.2
1361	PLC read index (PLC input buffer)	-	0 ... 33	1	7.1.2
 1362	PLC input buffer	-	Selection	7 - Off	7.1.2
PLC functions input buffer analog					
1377	PLC write index (PLC input analog)	-	0 ... 9	1	7.1.3
1378	PLC read index (PLC input analog)	-	0 ... 9	1	7.1.3
1379	PLC input buffer frequency	-	Selection	9 - zero	7.1.3
1380	PLC input buffer current	-	Selection	9 - zero	7.1.3
1381	PLC input buffer percent	-	Selection	9 - zero	7.1.3
1382	PLC input buffer voltage	-	Selection	9 - zero	7.1.3
1383	SPS input buffer general source	-	0 ... 2147483647	9	7.1.3
1384	Numerator general source input 1383	%	-327.68 ... 327.67	100.00	7.1.3
1385	Denominator general source input 1383	%	0.01 ... 327.67	100.00	7.1.3
1386	Numerator general source output 2551	%	-327.68 ... 327.67	100.00	7.1.3
1387	Denominator general source output 2551	%	0.01 ... 327.67	100.00	7.1.3
1388	PLC fixed frequency value	Hz	-999.99 ... 999.99	50.00	7.1.3
1389	PLC fixed current value⁵	A	-I _{max} ... I _{max}	I _{Rated}	7.1.3

⁴ Depending on instruction

⁵ Setting range and factory settings depend on device type

1390	PLC fixed percent value	%	-327.67 ... 327.67	100.00	7.1.3
1391	PLC fixed voltage value	V	-1000.0 ... 1000.0	565.7	7.1.3
1392	PLC fixed position value	units	-2 147 483 647 ... 2 147 483 647	65536	7.1.3
1393	PLC fixed speed value tab.pos.	u/s	-2 147 483 647 ... 2 147 483 647	163840	7.1.3
1394	PLC fixed ramp value tab.pos.	u/s ²	1 ... 2 147 483 647	327680	7.1.3
1395	PLC fixed general value	-	-32767 ... 32767	0	7.1.3
1396	Numerator fixed general value 1395	%	-327.68 ... 327.67	100	7.1.3
1397	Denominator fixed general value 1395	%	0.01 ... 327.67	100	7.1.3
PLC functions					
1399	PLC RunMode	-	Selection	0 - Stop	0

11 Annex

11.1 Mask: Diagram for digital instructions of function table

FT-Eingangspuffer 1362	Index 1	Index 2	Index 3	Index 4	Index 5	Index 6	Index 7	Index 8	Index 9	Index 10	Index 11	Index 12	Index 13	Index 14	Index 15	Index 16
Quelle:	2001	2002	2003	2004	2005	2006	2007	2008	2009	2010	2011	2012	2013	2014	2015	2016
Werkseinstellung:	70 - FU-Freigabe	71 - S2IND	72 - S3IND	73 - S4IND	74 - S5IND	75 - S6IND	76 - MFI1D	7 - Aus	7 - Aus	7 - Aus	160 - Bereitmeldung	161 - Laufmeldung	162 - Stoermeldung	163 - Frequenzsollwert erreicht	7 - Aus	7 - Aus
Geänderte Einstellung:																

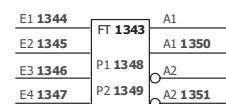
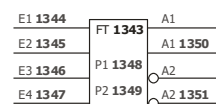
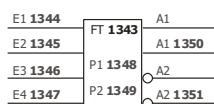
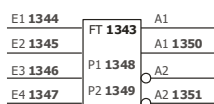
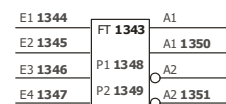
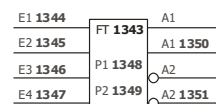
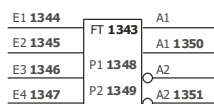
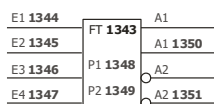
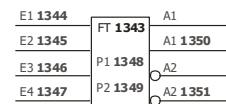
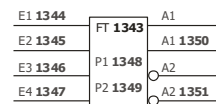
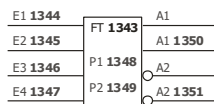
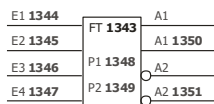
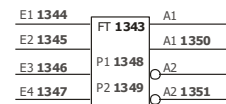
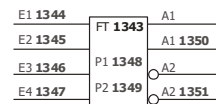
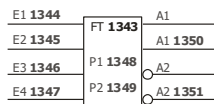
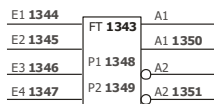
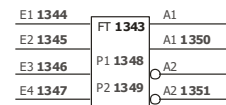
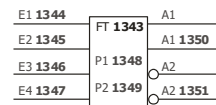
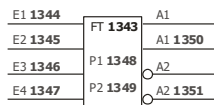
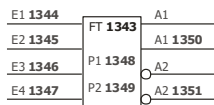
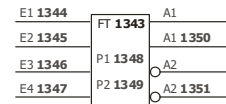
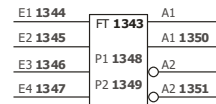
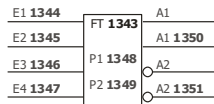
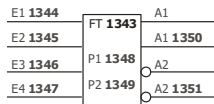

FT-Ausgangspuffer	Index 1	Index 2	Index 3	Index 4	Index 5	Index 6	Index 7	Index 8	Index 9	Index 10	Index 11	Index 12	Index 13	Index 14	Index 15	Index 16
Quelle:	2401	2402	2403	2404	2405	2406	2407	2408	2409	2410	2411	2412	2413	2414	2415	2416
Digitaler Ausgang:																

11.2 Mask: Functions settings

		1	2	3	4	5	6	7	8
FT-Instruction	1343								
FT-Input 1	1344								
FT-Input 2	1345								
FT-Input 3	1346								
FT-Input 4	1347								
FT-Parameter 1	1348								
FT-Parameter 2	1349								
FT-target output 1	1350								
FT-target output 2	1351								
FT-Commentary	1352								

		9	10	11	12	13	14	15	16
FT-Instruction	1343								
FT-Input 1	1344								
FT-Input 2	1345								
FT-Input 3	1346								
FT-Input 4	1347								
FT-Parameter 1	1348								
FT-Parameter 2	1349								
FT-target output 1	1350								
FT-target output 2	1351								
FT-Commentary	1352								

		17	18	19	20	21	22	23	24
FT-Instruction	1343								
FT-Input 1	1344								
FT-Input 2	1345								
FT-Input 3	1346								
FT-Input 4	1347								
FT-Parameter 1	1348								
FT-Parameter 2	1349								
FT-target output 1	1350								
FT-target output 2	1351								
FT-Commentary	1352								

		25	26	27	28	29	30	31	32
FT-Instruction	1343								
FT-Input 1	1344								
FT-Input 2	1345								
FT-Input 3	1346								
FT-Input 4	1347								
FT-Parameter 1	1348								
FT-Parameter 2	1349								
FT-target output 1	1350								
FT-target output 2	1351								
FT-Commentary	1352								

Index

A

Absolute value	
of three orthogonal components.....	108
of two orthogonal components.....	108
Absolute value function.....	111
Acknowledging an error.....	83
Actual value.....	164
analog.....	165
digital.....	164
Add two bits to a word.....	152
Addition.....	101
Long.....	102
Analog hysteresis.....	93
Analog multiplexer.....	124
AND operation.....	59
Automatic mode.....	141
Average	
over time.....	121
Average function.....	107

B

Bit functions for analog input values.....	145
Add two bits to a word.....	152
Bit AND/NAND.....	146
Bit arithmetical shift right.....	149
Bit NOT.....	145
Bit OR/NOR.....	147
Bit roll right.....	150
Bit shift left.....	150
Bit shift right.....	149
Bit XOR/XNOR.....	148
Output one bit.....	151
Unite four bits to form a word.....	151

C

Changeover switch for position values.....	126
Clock generator.....	57
Master.....	80
Superior.....	79
Combinations	
Input buffer and inputs.....	49
Inputs and outputs of instructions.....	47
Instructions with one another.....	51
Output buffer and device function.....	51
output buffer and digital output.....	53
Comparator	
Constant-Variable.....	89
Motion blocks.....	91
Positions.....	92
Window comparator	

Constant-Variable.....	96
Variables.....	94
Controlling digital output.....	53
Copyright.....	7
Counters.....	137, 138
Cube.....	112
Current parameter	
read.....	132
write.....	128

D

Debouncer.....	84
Delay.....	57
Master	
non-retriggerable.....	74
retriggerable.....	72
Superior	
non-retriggerable.....	73
retriggerable.....	71
Description of system.....	16
D-Flip-Flop	
Master.....	67
Superior.....	66
Differentiator.....	110
Digital Multiplexer (Data Set Number).....	81
Division	
Constant/variable.....	106
Variable/constant.....	106
Variables.....	105

E

Error messages.....	167
Example	
Run/Stop.....	158
Examples	
Combination	
Digital inputs of device.....	159
Instruction output with device function.....	52
Combination of instructions.....	160
Parameterization logic diagram.....	163
Signal source for digital output.....	53

F

Filter	
PT1 element.....	120
Spike filter.....	122
Font style.....	11
Frequency parameter	
read.....	131
write.....	127

Function table		
Run/Stop	158	
I		
Input buffer	49	
analog.....	31	
digital	31	
Inputs.....	44, 47	
analog.....	45	
digital	44	
Instructions		
overview.....	34	
Integrator	109	
J		
Jump function.....	57, 85	
for loops	86	
Jump target		
Chronological behavior	57	
L		
Limiter		
constant	135	
variable.....	136	
List of parameters.....	176	
Long parameter		
read	133	
write	130	
M		
Master	56	
Mathematical functions	100	
Min / Max	97	
Min/Max		
for position values.....	98	
for positions in time window	99	
in time window	99	
Modulo	113	
Monoflop.....	57	
Master		
non-retriggerable.....	78	
retriggerable	76	
Superior		
non-retriggerable.....	77	
retriggerable	75	
Motion block		
continue	142	
resume	143	
stop	142	
Multiplexer		
analog.....	124	
digital	81	
position values	125	
Multiplication	102	
and division.....	107	
by fraction.....	104	
Long result	103	
Long*percent	104	
MUX for position values	125	
N		
NOP	84	
O		
OR operation	59	
Output buffer		
analog	31	
digital	31	
Output one bit.....	151	
Output signals	164	
Outputs.....	45	
Overview table		
digital	57	
P		
P controller.....	114	
Parameter access		
current		
read.....	132	
write	128	
frequency		
read.....	131	
write	127	
long		
read.....	133	
write	130	
percent		
read.....	133	
write	129	
position		
read.....	133	
write	130	
voltage(eff.)		
read.....	132	
write	128	
voltage(peak)		
read.....	132	
write	129	
word		
read.....	134	
write	131	
PD(T1) controller	115	
Percent parameter		
read	133	
write	129	
PI controller		

Tn in milliseconds.....	114	as single motion	140
Tn in seconds.....	115	in automatic mode.....	141
PID(T1) controller		Statemachine	168
Tn in milliseconds.....	116	Stopwatch with analog output.....	138
Tn in seconds.....	118	Superior	56
Position parameter		Switch data set	81
read	133	Switching time.....	68
write	130		
Positioning functions	140	T	
motion block		Time average	121
continue.....	142	Timer functions	75
resume	143	Toggle-Flip-Flop	
Start homing.....	143	Master.....	65
Start motion block as single motion	140	Superior	63
Start motion block in automatic mode	141	Triggering of an error.	81
Stop motion block.....	142		
PT1 element	120	U	
R		Unite four bits to form a word	151
Ramp limitation	121	Up/Down counter with analog output.....	137
Read index		V	
Analog input buffer	156	Voltage parameter	
Digital input buffer	155	read (eff.)	132
FT instructions.....	154	read (peak).....	132
Reciprocal	106	write (eff.)	128
RS-Flip-Flop		write (peak).....	129
Master	62	W	
Superior.....	61	Window comparator	
Run/Stop.....	158	variables.....	94
S		Window Comparator	
Service	14	Constant-Variable	96
Signal sources		Word parameter	
analog.....	30	read.....	134
digital	28	write.....	131
for analog output	167	Write index	
for device function	167	Analog input buffer	156
for digital output	166	Digital input buffer	155
Single motion.....	140	FT instructions.....	154
Spike filter.....	122	X	
Square.....	111	X ² 111	
Square root.....	112	X ³ 112	
square root(x).....	112	XOR 1 3 operation.....	60
Start homing.....	143	XOR 1 operation	60
Start motion block			

AUSTRALIA

Bonfiglioli Transmission (Aust.) Pty Ltd

2, Cox Place Glendenning NSW 2761
Locked Bag 1000 Plumpton NSW 2761
Tel. +61 2 8811 8000



BRAZIL

Bonfiglioli Redutores do Brasil Ltda

Travessa Cláudio Armando 171 -
Bloco 3 CEP 09861-730 - Bairro
Assunção
SãoBernardodoCampo-SãoPaulo
Tel. +55 11 4344 2322



CHINA

Bonfiglioli Drives (Shanghai) Co. Ltd.

#68, Hui-Lian Road, QingPu
District, 201707 Shanghai
Tel. +86 21 6700 2000



#568, Longpan Road, Jiading District,
201707 Shanghai



Bonfiglioli Trading (Shanghai) Co. Ltd.

Room 423, 4th Floor, #38, Yinglun
Road, China (Shanghai) Pilot Free
Trade Zone, Shanghai



FRANCE

Bonfiglioli Transmission s.a.

14 Rue Eugène Pottier
Zone Industrielle de Moimont II
95670 Marly la Ville
Tel. +33 1 34474510



GERMANY

Bonfiglioli Deutschland GmbH

Sperberweg 12 - 41468 Neuss
Tel. +49 0 2131 2988 0



Bonfiglioli Deutschland GmbH Krefeld

Europark Fichtenhain B6 - 47807 Krefeld
Tel. +49 0 2151 8396 0



O&K Antriebstechnik GmbH

Ruhrallee 8-12 - 45525 Hattingen
Tel. +49 0 2324 2050 1



INDIA

Bonfiglioli Transmission Pvt. Ltd.

Mobility & Wind Industries

AC 7 - AC 11 Sidco Industrial Estate
Thirumudivakkam Chennai - 600 044
Tel. +91 844 844 8649



Discrete Manufacturing & Process Industries - Motion & Robotics

Survey No. 528/1,
Perambakkam High Road Mannur
Village,
Sriperumbudur Taluk Chennai - 602105
Tel. +91 844 844 8649



Discrete Manufacturing & Process Industries

Plot No.A-9/5, Phase IV MIDC Chakan,
Village Nighoje Pune - 410 501
Tel. +91 844 844 8649



ITALY

Bonfiglioli S.p.A. Riduttori Discrete Manufacturing &

Process Industries

Via Cav. Clementino Bonfiglioli, 1
40012 Calderara di Reno
Tel. +39 051 6473111



Discrete Manufacturing & Process Industries

Via Sandro Pertini, lotto 7b
20080 Carpiano
Tel. +39 02985081



Discrete Manufacturing & Process Industries

Via Saliceto, 15 - 40010 Bentivoglio



Mobility & Wind Industries

Via Enrico Mattei, 12 Z.I. Villa Selva
47122 Forlì
Tel. +39 0543 789111



Motion & Robotics

Via Unione, 49 - 38068 Rovereto
Tel. +39 0464 443435/36



NEW ZEALAND

Bonfiglioli Transmission (Aust.) Pty Ltd

88 Hastie Avenue, Mangere Bridge,
2022 Auckland
PO Box 11795, Ellerslie
Tel. +64 09 634 6441



SINGAPORE

Bonfiglioli South East Asia Pte Ltd

8 Boon Lay Way, #04-09,
8@ Tadehub 21, Singapore 609964
Tel. +65 6268 9869



SLOVAKIA

Bonfiglioli Slovakia s.r.o.

Robotnícka 2129
Považská Bystrica, 01701 Slovakia
Tel. +421 42 430 75 64



SOUTH AFRICA

Bonfiglioli South Africa Pty Ltd.

55 Galaxy Avenue, Linbro Business Park,
Sandton, Johannesburg
2090 South Africa
Tel. +27 11 608 2030



SPAIN

Tecnotrans Bonfiglioli S.A

Pol. Ind. Zona Franca, Sector C,
Calle F, nº 6 - 08040 Barcelona
Tel. +34 93 447 84 00



TURKEY

Bonfiglioli Turkey Jsc

Atatürk Organize Sanayi Bölgesi,
10007 Sk. No. 30
Atatürk Organize Sanayi Bölgesi,
35620 Çiğli - İzmir
Tel. +90 0 232 328 22 77



UNITED KINGDOM

Bonfiglioli UK Ltd.

Unit 1 Calver Quay, Calver Road, Winwick
Warrington, Cheshire - WA2 8UD
Tel. +44 1925 852667



USA

Bonfiglioli USA Inc.

3541 Hargrave Drive
Hebron, Kentucky 41048
Tel. +1 859 334 3333



VIETNAM

Bonfiglioli Vietnam Ltd.

Lot C-9D-CN My Phuoc Industrial Park 3
Ben Cat - Binh Duong Province
Tel. +84 650 3577411



 PRODUCTION

 ASSEMBLY

 SALES

 SERVICE



Abbiamo un'inflessibile dedizione per l'eccellenza, l'innovazione e la sostenibilità. Il nostro Team crea, distribuisce e supporta soluzioni di Trasmissioni e Controllo di Potenza per mantenere il mondo in movimento

We have a relentless commitment to excellence, innovation & sustainability. Our team creates, distributes and services world-class power transmission & drive solutions to keep the world in motion.

Wir verpflichten uns kompromisslos zu Qualität, Innovation und Nachhaltigkeit. Unser Team entwickelt, vertreibt und wartet erstklassige Energieübertragungs- und Antriebslösungen, um die Welt in Bewegung zu halten

Notre engagement envers l'excellence, l'innovation et le développement durable guide notre quotidien. Notre Équipe crée, distribue et entretient des solutions de transmission de puissance et de contrôle du mouvement contribuant ainsi à maintenir le monde en mouvement.

Tenemos un firme compromiso con la excelencia, la innovación y la sostenibilidad. Nuestro equipo crea, distribuye y da soporte en soluciones de transmisión y control de potencia para que el mundo siga en movimiento.

COD. VEC 701 R1

HEADQUARTERS
Bonfiglioli S.p.A
Registered Office: Via Bazzane, 33
40012 Calderara di Reno BO
Head office: Via Isonzo, 65/67/69
40033 Casalecchio di Reno BO
ITALY

tel: +39 051647 3111
www.bonfiglioli.com